

**NOTES:**

1. Dimensions are in inches (mm) and may vary  $\pm 1/4"$  (6).
2. Batteries are 12 volt, lead-acid type D-8D, approximately 95 lbs. each, dry.
3. Batteries are shipped dry. Electrolyte (approx. 19 quarts per battery) must be procured locally.
4. Refer to Section 916 page 252 for exact number of batteries & cables to be furnished based on the diesel engine manufacturer and model used.
5. Battery racks are fabricated steel, approximately 20 lbs. each.
6. Each rack holds 2 batteries. Racks are not to be stacked.

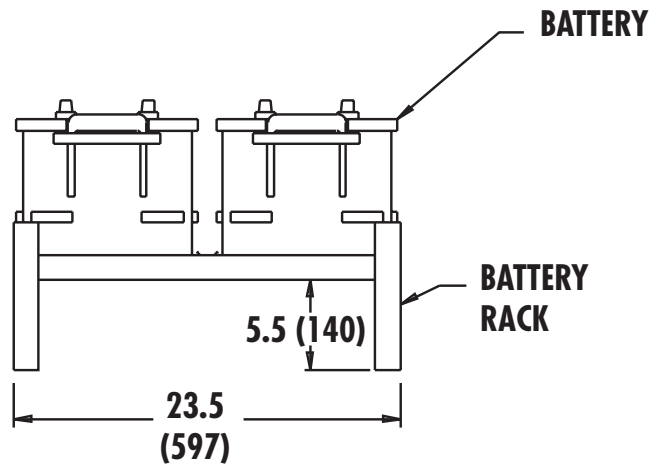
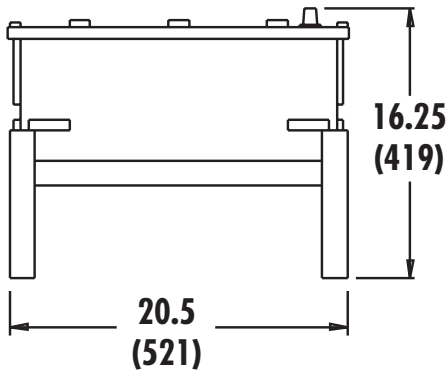

**NOTES:**

1. All cables are SAE J55BA type SGT with tensile attachment of 700-800 lbs.
2. Positive & negative cables 60" (1524) long are 2/0 gauge; positive & negative cables 80" (2032) long are 3/0 gauge.
3. Terminal clamps have steel reinforced inserts.
4. Not all cable types are required for every engine. Refer to Section 916 page 252 for cable applicability.

