



INSTRUCTION MANUAL

REPAIR

MODEL 671-672

6

SERVICE

Your Aurora pump requires no maintenance other than periodic inspection, occasional cleaning and lubrication. The intent of inspection is to prevent breakdown, thus obtaining optimum service life. The pumped liquid determines the type of pump and line bearings supplied and method of bearing lubrication. Refer to lubrication section for specific instruction. The motor may also require lubrication, in which case, the motor manufacturer's recommendation should be followed.

LUBRICATION (BALL BEARINGS)

Regreasable bearings will require periodic lubrication and can be accomplished by using the zerk or lubrication fittings in the lower head assembly. Lubricate the bearings at regular intervals using a grease of high quality. Lithium, lithium soda or calcium base grease is recommended as lubricants for pumps operating in both wet and dry locations. Mixing of different brands of grease should be avoided due to possible chemical reactions between the brands which could damage the bearing. Accordingly, avoid grease of vegetable or animal base which can develop acids, as well as grease containing rosin, graphite, talc and other impurities. Under no circumstances should grease be reused.

Over lubrication should be avoided as it may result in overheating and possible bearing failure. Under normal application, adequate lubrication is assured if the amount of grease is maintained at 1/3 to 1/2 the capacity of the bearing and adjacent space surrounding it.

In dry locations each bearing will need lubrication at least every 4,000 hours of running time or every 6 to 12 months, whichever is more frequent. In wet locations the bearings should be lubricated at least after every 2,000 hours of running time or every 4 to 6 months, whichever is more frequent. A unit is considered to be installed in a wet location if the head assembly and motor are exposed to dripping water, to the weather, or to heavy condensation such as is found in unheated and poorly ventilated underground locations.

At times it may be necessary to clean the bearings due to accumulated dirt or deteriorated lubricants. This can be accomplished by flushing the bearing with a light oil heated to 180 to 200° F. while rotating it on a spindle. Wipe the bearing housing with a clean rag soaked in a cleaning solvent, and flush all surfaces.

Dry bearing thoroughly before relubricating. Compressed air can be used to speed drying, but care should be taken not to let bearings rotate while being dried.

CAUTION

Use normal fire caution procedures when using any petroleum cleaner.

LUBRICATION (LINE SHAFT & PUMP BEARINGS)

Grease lubricated sleeve bearings (standard and relief type) will require frequent lubrication which can be accomplished by using the zerk fitting(s) located on the pump base. It is suggested that relubrication intervals be every 20 hours of running time.

Graphitor, cutless rubber and teflon bearings are lubricated with a water flush. The required number of lube line connections are provided on the pump base.

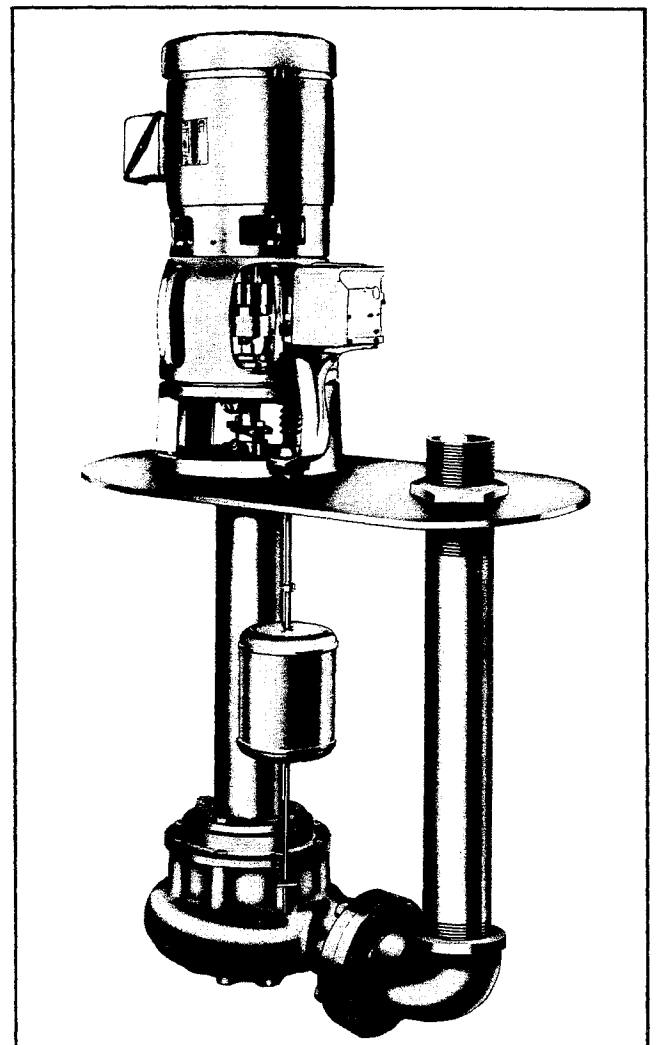

A. Complete unit assembly.

REPAIRS

The pump may be disassembled using the illustrations and text provided. Although complete disassembly is covered, it will seldom be necessary to completely disassemble your Aurora pump.

The illustrations accompanying the disassembly instructions show the pump at various stages of disassembly. The illustrations are intended to aid in the correct identification of the parts mentioned in the text.

Inspect removed parts at disassembly to determine their reusability. Pump or line shaft bearings that are scored or noticeably out of round should not be reassembled. Cracked castings should never be reused and scored or worn pump shafts should be replaced.

All packings and gaskets should be replaced with new ones at reassembly simply as a matter of economy. They are much less expensive to replace routinely than to replace singly as the need arises. In general, it is economical to return to the manufacturer for repair only the motor and motor controller.

DISASSEMBLY

Disassemble only what is needed to make repairs or accomplish inspection. Proceed to disassemble the pump as follows: (Refer to figure 1.)

1. Disconnect wiring from motor control panel to motor and float switch. Take any other steps needed to prevent drive unit from being unintentionally energized during disassembly.

2. Remove the float switch. For instructions, refer to the repair notes on float switches.

3. Pump motor (52) and upper head (53) are best removed as a unit. The upper head serves to protect the motor output shaft from accidental damage. Therefore, remove capscrews (42) and lift the unit free from lower head (84) and lower half of coupling

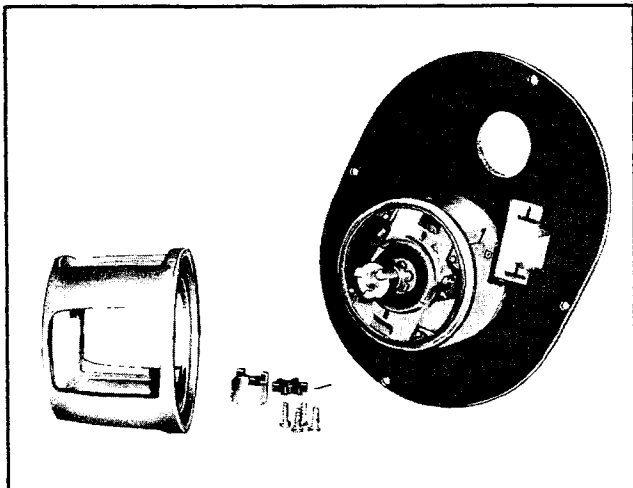

B. Upper head, coupling half, key and insert removed.

(48). If necessary, upper head (53) may be removed from motor (52) by unthreading capscrews (51) and removing nuts (50).

4. Coupling half (48) is removed by loosening setscrew (47). Similarly, setscrew (44) will free upper coupling half (45). Remove coupling keys (46 and 49) and insert (43).

5. Remove remaining pump and connected parts from basin to continue disassembly.

NOTE

However, if ventilation piping is used, remove it before lifting off plate.

6. Locknut (55) can be unthreaded, exposing slinger (54) for removal. Then bearing collar (56) with ball bearing (58) is unthreaded from pump shaft. Retaining ring (57) must be removed from collar (56) with a pair of Truarc pliers, if bearing (58) is to be pressed off collar (56).

7. Remove grease seal (59) if necessary.

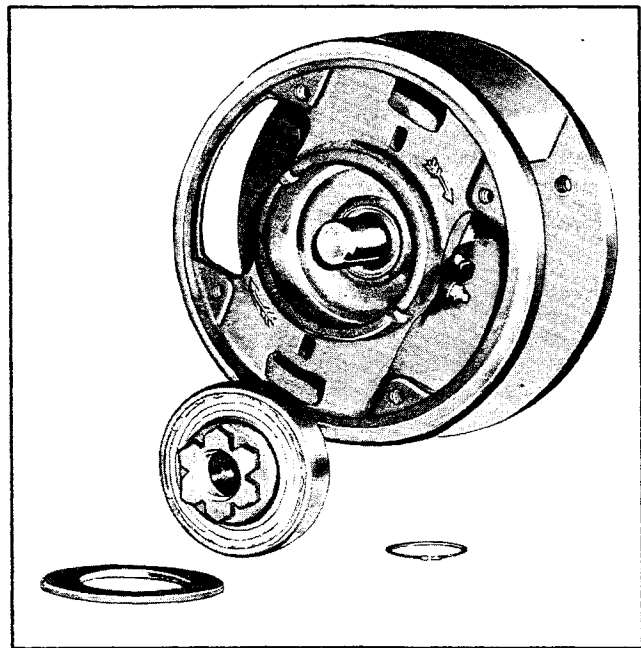

C. Slinger, bearing collar, bearing and retaining ring removed.

NOTE

Grease seal (59) should not be removed except for replacement because it's case is easily damaged. When removal is necessary, it can be tapped out of its seat in the lower head with coupling key (49) used as a driving tool.

8. Remove nuts (66) and clamps (67) from studs (69) and slide gland (68) off shaft (61). Remove packing (70) and packing ring (71). Remove lantern ring (optional - 72).

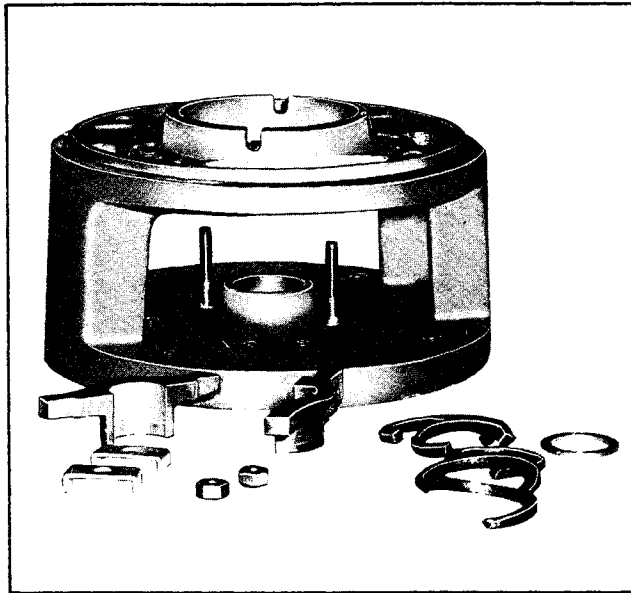

D. Nuts, clamps, gland halves, packing and packing ring removed from lower head.

9. Remove oiler (73) if used and pipe plug (63). Also disconnect any lubrication line used to lubricate line shaft bearings or piping for pressurized support column water supply.

10. Unscrew capscrews (80 and 81) to remove lower head (84). Remove gasket (85).

11. Remove upper locknut (77) from discharge piping (78). Then plate can be lifted off.

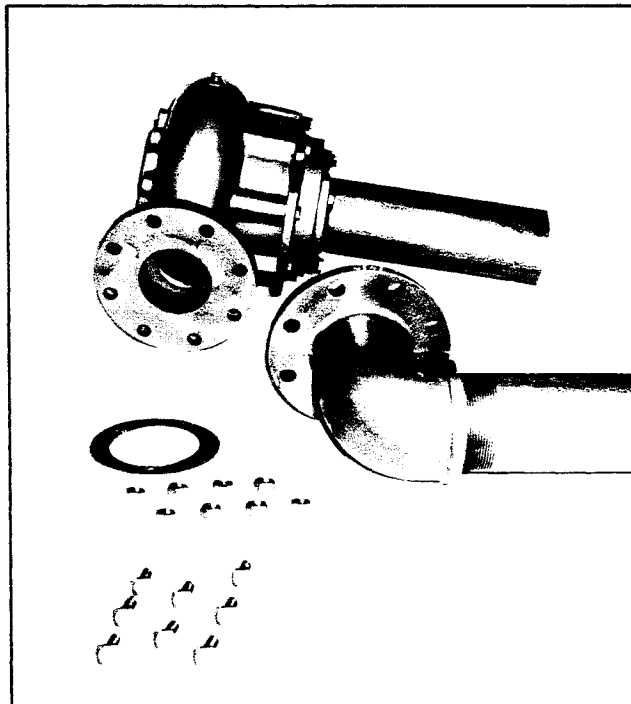

E. Nuts, capscrews and gasket removed to free discharge piping.

Remove gasket (23). Remove screws (83) and nameplate (82) only if replacement is necessary.

12. Successive lengths of piping and shafting are disassembled as follows:

- a. If a line shaft bearing is lubricated through a lubrication line, detach the line and elbow from pipe nipple in upper support section and then remove nipple.
- b. Unscrew capscrews (39) and nuts (38) to lift top support pipe section and expose shaft coupling (60). Use a wrench to hold shaft (61) and a second wrench to unscrew coupling (60). Remove gasket (23).
- c. Remove pipe plug (25) if used, then slide line shaft bearing (41) off shaft.
- d. For additional lengths of discharge pipe (78) use a large pipe wrench to hold discharge pipe and a second wrench to unscrew coupling (79).

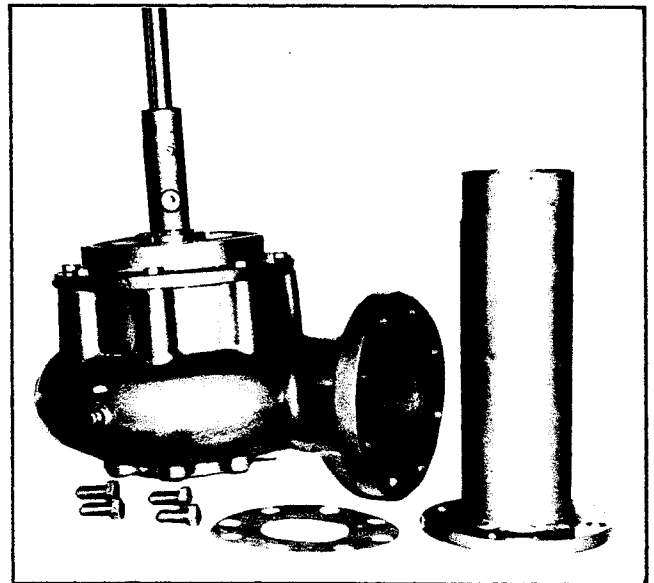

F. Nuts, support piping and gasket removed from cover.

CAUTION

To protect a bearing that can be reused, tape the threaded section of the shaft end before removing bearing.

13. Discharge piping (78) and flanged elbow (76) can be removed from casing (8) by unthreading capscrews (5) and nuts (6). Remove gasket (9).

14. To lift off remaining support piping (40) unscrew capscrews (21). Remove gasket (23).

15. Unthread capscrews (7) to remove cover (22) and gasket (10) exposing impeller.

MODEL 671-672

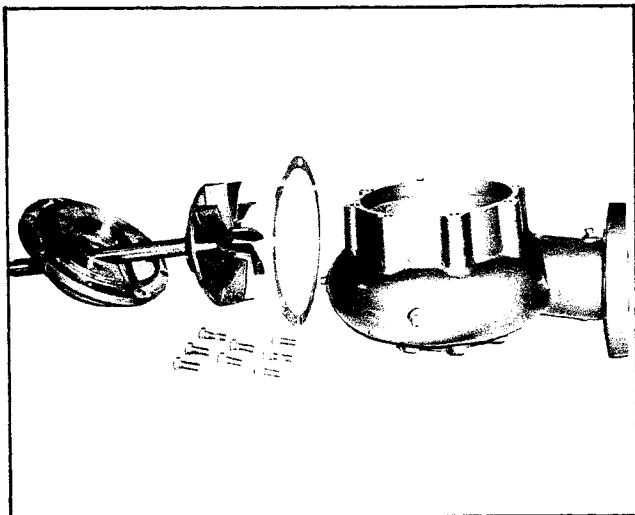

G. Capscrews, cover, casing and gasket removed to reveal impeller.

16. Lift remaining shafting (61), impeller (15) and pump bearing (26) from casing (8). Remove pipe plug (25) from bearing (26), then slide bearing off end of the shaft, using the afore mentioned caution.

17. Unscrew impeller capscrew (13), remove gasket (14), impeller (15) and impeller key (16).

REASSEMBLY

Reassembly will generally be in reverse order of disassembly. If disassembly was not complete, use only those steps related to your particular repair program.

1. Slide pump bearing (26) onto pump end of shafting (61) using the last caution mentioned in disassembly with the flanged end of bearing toward the bottom end of shaft. If bearing is not to be lubricated through a lubricating line, place pipe plug (25) in tapped hole in bearing.

2. Slide pump shaft (61) into pump end of support piping (40). Position pump bearing against pump flange of support piping. If bearing is to be lubricated through a lubrication line, align tapped opening in the bearing with vent opening in the support pipe, and install an 1/8 inch pipe nipple to maintain the alignment.

3. Slide cover (22) onto shaft (61). Place impeller key (16) in shaft and replace impeller (15) on shaft. Secure impeller with impeller capscrew (13) and gasket (14).

4. Position gasket (10) on cover (22) and bolt to casing (8) with capscrews (7).

5. Place gasket (23) on cover (22). With discharge outlet aligned with vent opening in support pipe, bolt cover to flanged support pipe (40) with capscrews (21).

6. Bolt discharge flanged elbow (76), with gasket (9) in place, to casing with capscrews (5) and nuts (6). Lengths of discharge pipe (78) may now be replaced in flanged elbow (76).

NOTE

If pump bearing is to be lubricated through a lubrication line, assemble the required elbow and tubing on previously installed nipple. If support column is to be pressurized with a flow of fresh water, connect the required 3/4 inch pipe nipple, elbow and pipe to support piping, and ascertain that other vent openings are plugged.

7. Successive lengths of piping and shafting are assembled as follows: (Pumps designed for pump settings* deeper than 6 feet, 6 inches are provided with multiple part discharge and support piping and with line shaft bearings at each support piping joint.)

- a. Slide a line shaft bearing (41) down pump shaft, with tapped opening toward upper end until it seats against the flange of the previously assembled section of support piping (40).
- b. To add successive lengths of pump shafting, thread shaft coupling (60) onto threaded end of one shaft (61). Start second piece of shafting into opposite end of coupling. Tighten both shafts evenly into coupling with pipe wrenches being careful not to score shafting excessively. There should be an even amount of shaft threads showing on either side of the coupling after tightening.
- c. If line shaft bearing is to be lubricated through a lubrication line, turn bearing as required to align tapped opening with lubricant piping. Position support pipe gasket (23) against support pipe flange, and lower the next section of support piping into place. Turn it to align vent opening with tapped opening in line shaft bearing, and secure it by installing bolts (39) and nuts (38). Install any 1/8 inch pipe nipple in tapped opening of line bearing if required, and connect it to previously assembled lubrication piping.

MODEL 671-672

- d. If necessary, screw a discharge pipe coupling (79) onto threaded end of previously assembled section of discharge piping, and thread the next section of piping into coupling. Tighten with a pipe wrench, using a second wrench to hold the previously assembled section.

*"Pump Setting" is the distance from bottom of casing (8) to bottom of lower head (84). This measurement is normally 6 inches less than "Pit Depth," the distance from bottom of basin to top face of basin.

8. Place locknut (77) on discharge pipe (78) and thread down approximately 1 inch.

9. Lower pump support plate over support piping (40) and discharge piping (78). Position gasket (23) on support pipe flange, gasket (85) on lower head and slide lower head (84) into place.

NOTE

Install float control at this time if liquid end is not accessible when ejector is lowered into basin.

10. Lift pump support plate into position against lower head (84) and install capscrews (80 and 81). Place locknut (77) on discharge pipe (78) and tighten locknuts above and below the plate to secure discharge piping in place. If pipe plugs (12) were removed, replace in casing (8). Pump support plate and pump assembly may now be lowered into place on basin cover and can be bolted down.

11. Install pump shaft packing ring (71) and packing (70) around shaft in lower head. Assemble packing gland halves (68) on gland studs (69) and secure with gland clamps (67) and nuts (66). Do not tighten nuts more than finger tight unless pump support piping is to be pressurized with fresh water.

12. Seat grease seal (59) with sealing edge upward in its seat in lower head.

NOTE

Cover threads of pump shaft temporarily with a tape or some other means before sliding on grease seal to prevent threads from damaging seal.

13. Press ball bearing (58) onto bearing collar (56) with ball bearing seal facing flange on collar, and secure bearing on collar by installing retaining ring (57).

14. Thread bearing collar onto pump shaft with bearing surface downward. Turn collar clockwise until impeller contacts bearing cover and shaft will not turn freely. Turn counterclockwise one-half turn. This will lower shaft and impeller approximately .020" inch, providing the correct clearance for efficient pump operation.

15. Hold bearing collar (56) and install locknut (55) against collar. Ascertain that pump shaft turns freely by hand. Press rubber slinger (54) into place on bearing collar.

NOTE

Connect pressurization or lubrication piping at this time by using opening provided in pump support plate. For pressurization piping, a 3/4 inch line to water supply is connected to tapped opening in lower head. For lubrication piping, line is connected to lubrication device. If no lubrication line is required and there are line shaft bearings, install oiler (73) and pipe plug (63) in openings provided in lower head.

16. Install coupling half (48) and key (49) on upper end of pump shaft, and tighten coupling setscrew (47) temporarily to prevent its slipping down shaft.

17. Position coupling insert (43) in lower half of coupling and secure upper coupling half (45) with its key (46) on motor output shaft. Align bottom end of key with key slot in the end surface of motor shaft, and secure by tightening setscrew (44).

18. If upper head (53) was removed from motor (52) replace with capscrews (51) and nuts (50). Lower motor (52) and upper head (53) carefully into position on lower head while engaging coupling halves with coupling insert. Bolt assembly to lower head with capscrews (42).

19. Loosen setscrew (47) in lower coupling half (48) and slide coupling half and key (49) upward until they engage coupling insert (43) with proper clearance as shown in Section 2, Item 4 of this Instruction Manual.

20. If nameplate (82) was removed replace at this time with screws (83).

NOTE

Install float switch at this time. For instructions refer to the repair notes on float switches.

21. Connect wiring from motor control panel to motor and float switch, following exactly the instructions provided by their respective manufacturers. Also connect solenoid valve or oiler at this time if used, using diagrams provided. All wiring must comply with applicable electrical code requirements for type of duty pump is to perform.

MODEL 671-672

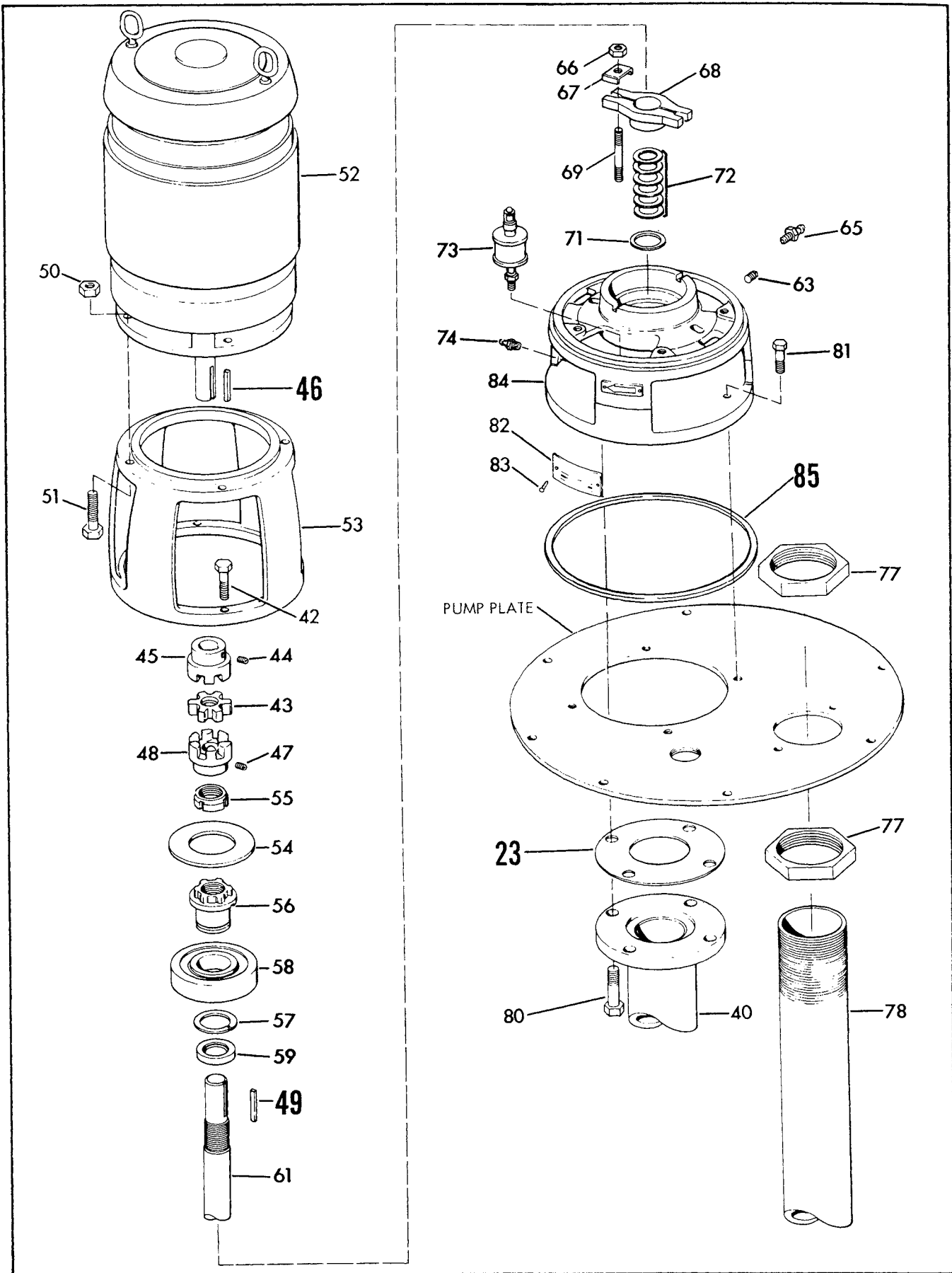

Figure 1. Model 671-672 Exploded View (Sheet 1 of 4)

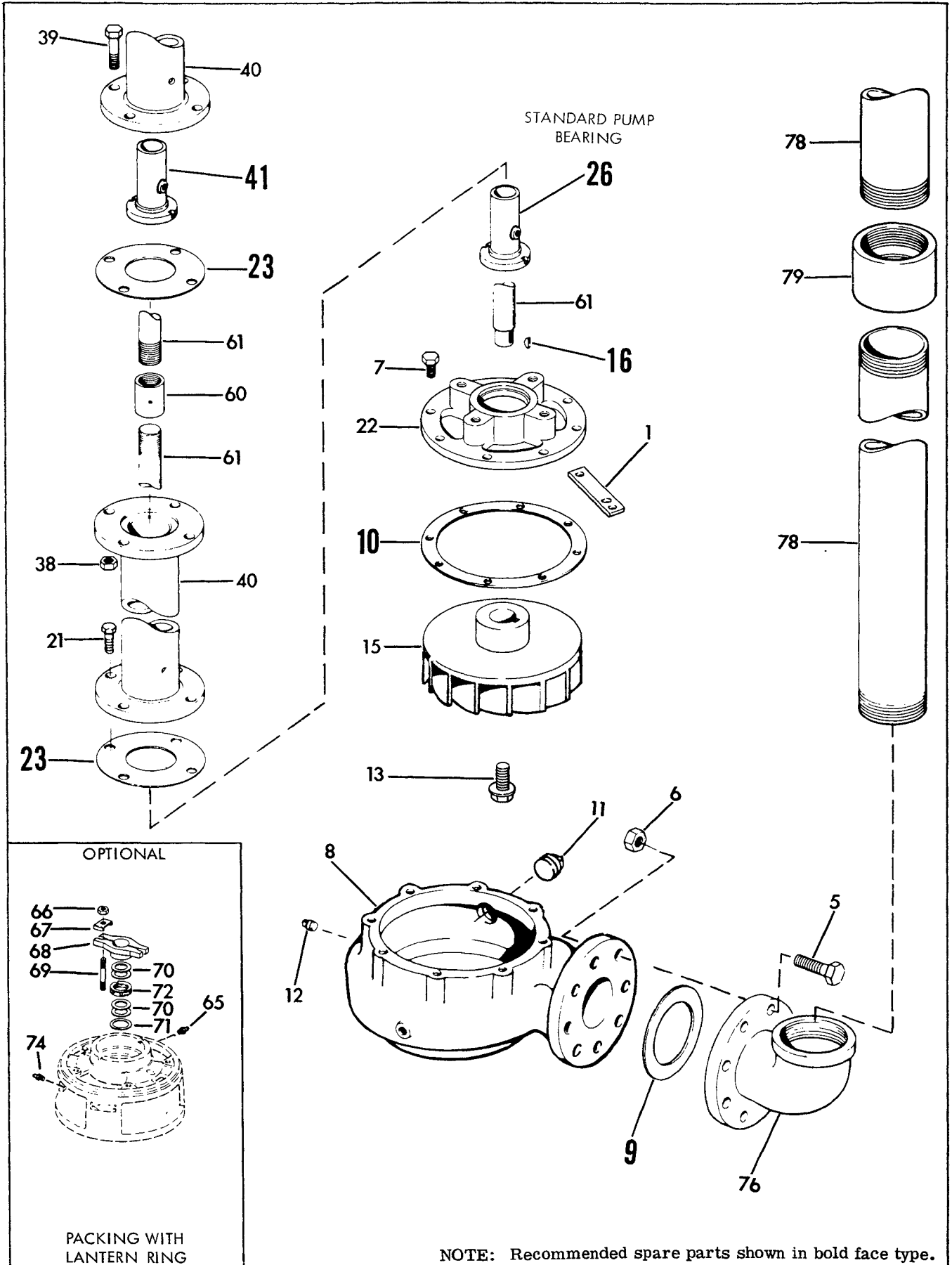
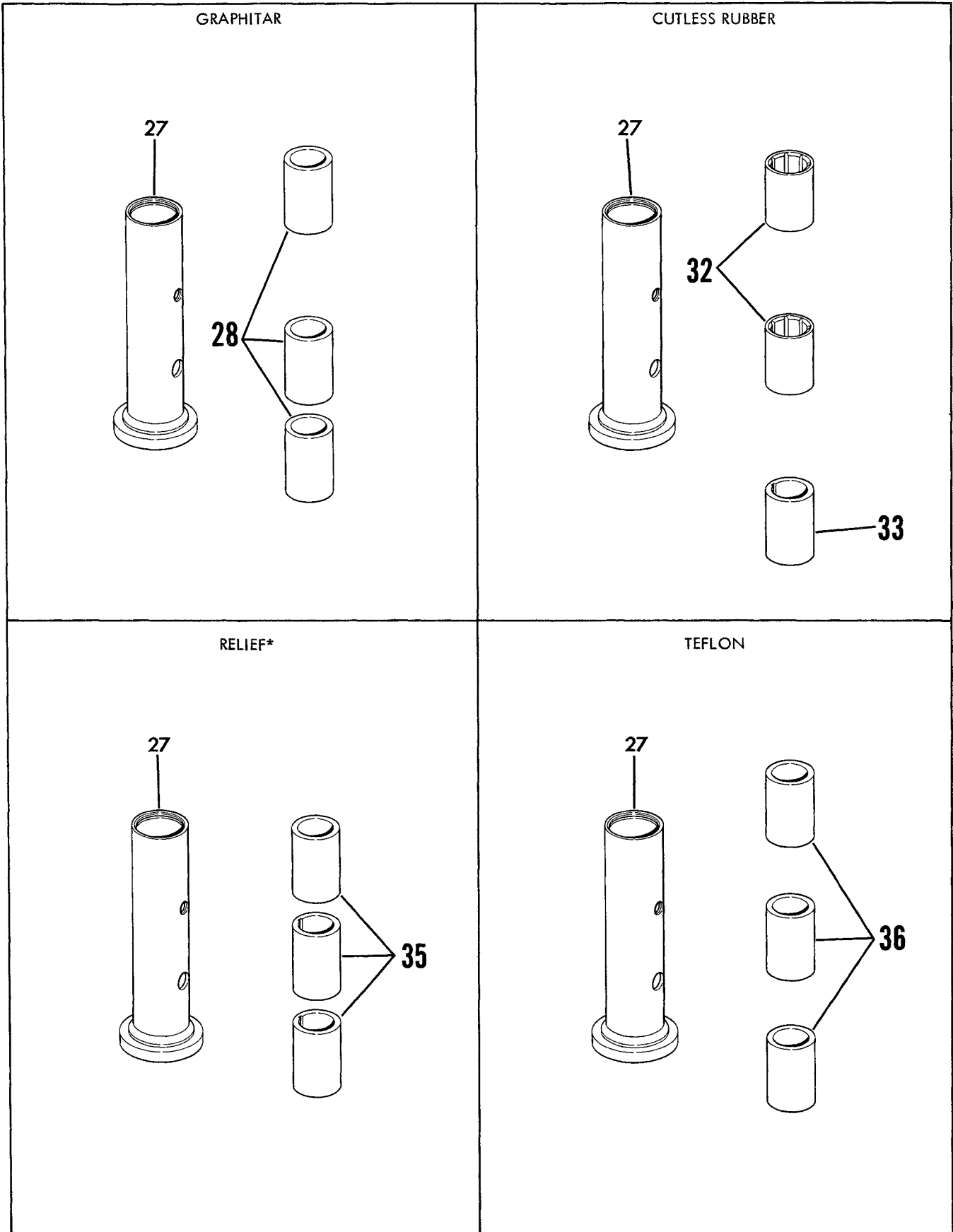

Figure 1. Model 671-672 Exploded View (Sheet 2 of 4)

MODEL 671-672
OPTIONAL RELIEF HOUSING



*Standard for pump settings over 10 feet.

Figure 1. Model 671-672 Exploded View (Sheet 3 of 4)

MODEL 671-672
OPTIONAL SPOOL HOUSING

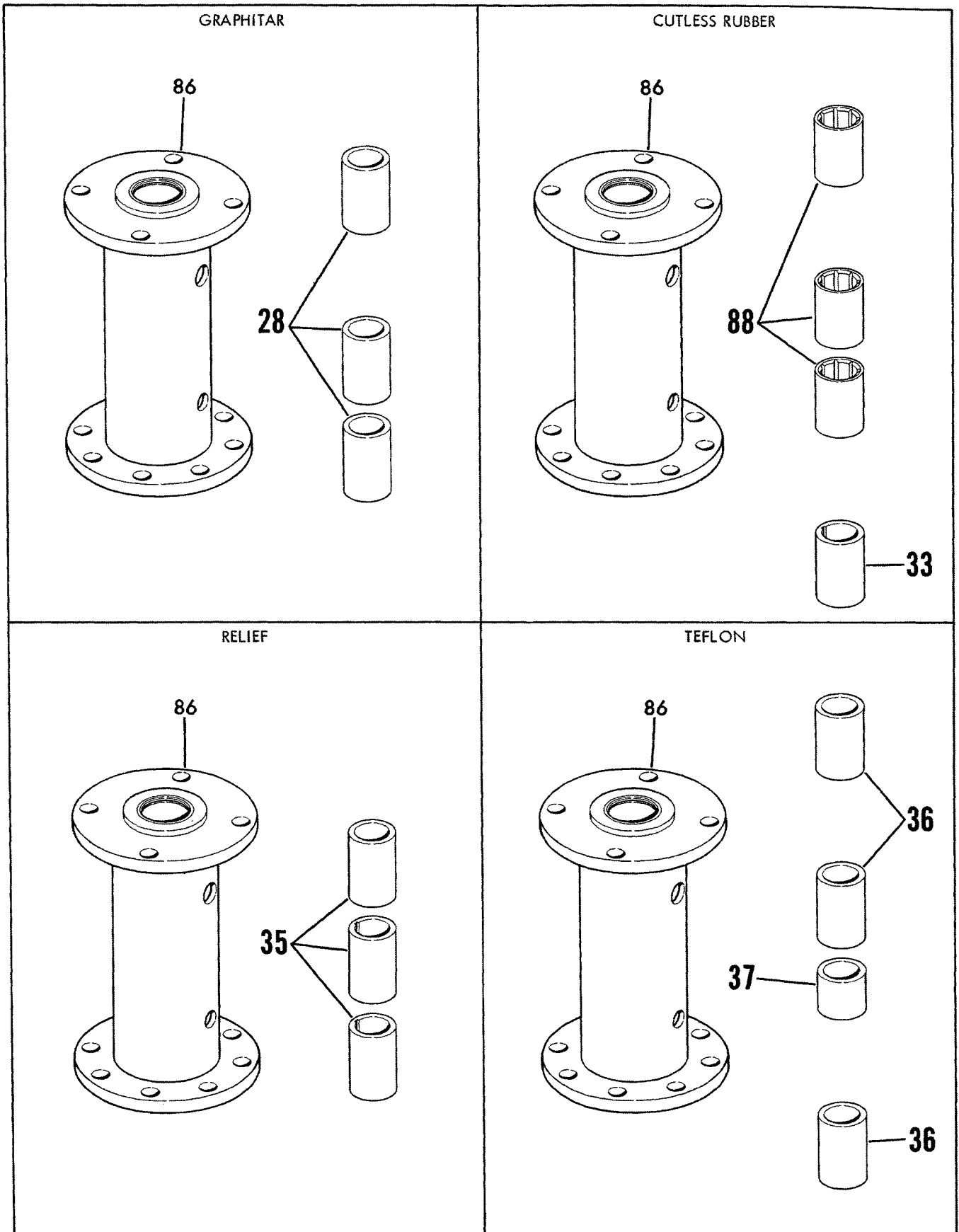

Figure 1. Model 671-672 Exploded View (Sheet 4 of 4)

MODEL 671-672

Model 671-672 List of Parts (See Figures 1 & 2)

1. Rod guide	35. Bushing (opt)	57. Retaining ring	82. Nameplate
5. Capscrew	36. Bushing (opt)	58. Bearing	83. Screw
6. Nut	37. Bushing (opt)	59. Seal	84. Lower head
7. Capscrew	38. Nut	60. Coupling, shaft	85. Gasket
8. Casing	39. Capscrew	61. Shaft	86. Spool bearing housing (opt)
9. Gasket	40. Support pipe	63. Plug, pipe	88. Bushing (opt)
10. Gasket	41. Bearing	65. Fitting (opt)	90. Grease fitting
11. Plug, pipe	42. Capscrew	66. Nut	91. Elbow
12. Plug, pipe	43. Insert	67. Clamp	92. Coupling
13. Impeller nut	44. Setscrew	68. Gland	93. Close nipple
14. Gasket	45. Coupling half	69. Stud	94. Nipple
15. Impeller	46. Key	70. Packing	95. Comp. fitting
16. Impeller key	47. Setscrew	71. Packing ring	96. Comp. fitting
21. Capscrew	48. Coupling half	72. Lantern ring (opt)	97. Nylon tube
22. Cover	49. Key	73. Oiler (opt)	
23. Gasket	50. Nut	74. Fitting (opt)	
25. Float rod guide	51. Capscrew	76. Flanged elbow	
26. Pump bearing	52. Motor	77. Locknut	
27. Bearing housing (opt)	53. Upper head	78. Discharge pipe	
28. Bushing (opt)	54. Slinger	79. Coupling, pipe	
32. Bushing (opt)	55. Locknut	80. Capscrew	
33. Bushing (opt)	56. Bearing collar	81. Capscrew	

NOTE

WHEN ORDERING SPARE PARTS ALWAYS INCLUDE THE PUMP TYPE, SIZE, SERIAL NUMBER, AND THE PIECE NUMBER FROM THE EXPLODED VIEW IN THIS MANUAL.

ORDER ALL PARTS FROM YOUR LOCAL AUTHORIZED DISTRIBUTOR, FACTORY BRANCH SALES OFFICE OR THE FACTORY AT NORTH AURORA, ILLINOIS

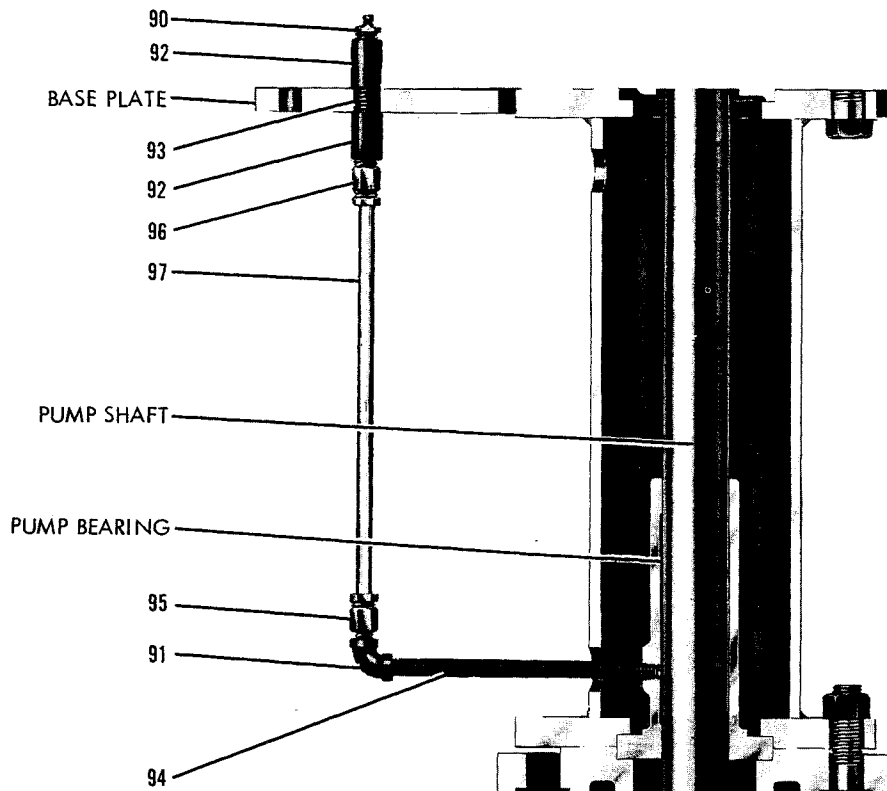

Figure 2.