

ENGINEERING DATA

INTERCHANGEABILITY

Non-Clog pumps are designed for maximum interchangeability. All models are available in all 6 sizes, offering a model and size precisely fitted to the installation requirements over a wide range of capacities. The 6 sizes are divided into 3 "Power Frames". Within a given power frame, all parts are interchangeable except for the liquid end and supports. The chart illustrates the degree of interchangeability achieved with the standard non-clog vortex pumps.

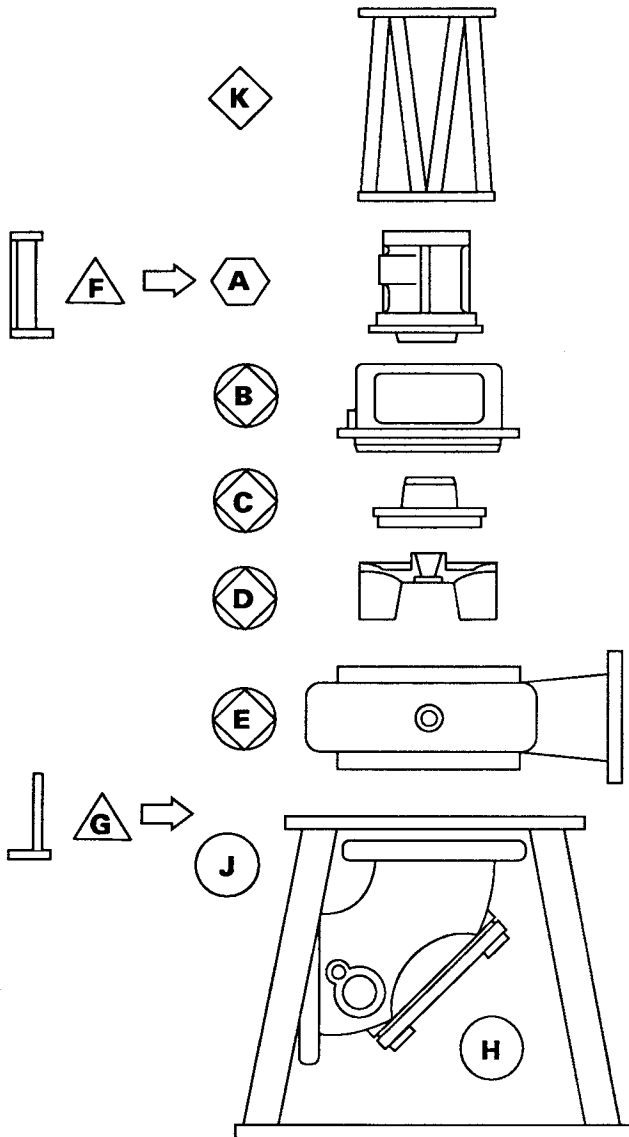

- Model 661A Only▲
- Model 663A Only◇
- Models 662A, 663A, & 664A○
- Models 661A, 662A, & 663A◊
- Models 661A, 662A, 663A, & 664A◐

	Qty
A - Power Frames	3
B - Brackets	5
C - Stuffing Boxes	3
D - Impellers	7
E - Casings	6
F - Mounting Feet (Rear)	3
G - Mounting Feet (Front)	3
H - Elbows	3
J - Bases	2
K - Motor Supports	3

POWER FRAME SELECTION

PUMP SIZE	RPM			
	1750	1150	875	700
3x3x9	3C	3C	3C	
4x4x9	3C	3C	3C	
3x3x12	3C	3C	3C	
4x4x12	3C	3C	3C	
6x6x12	5E	4C	4C	
6x6x15		5E	5E	5E

AURORA 660A SERIES ENGINEERING DATA

INTERCHANGEABILITY

**POWER
FRAMES
(3)**

**BRACKETS
(5)**

**STUFFING
BOXES
(3)**

**IMPELLERS
(7)**

**CASINGS
(6)**

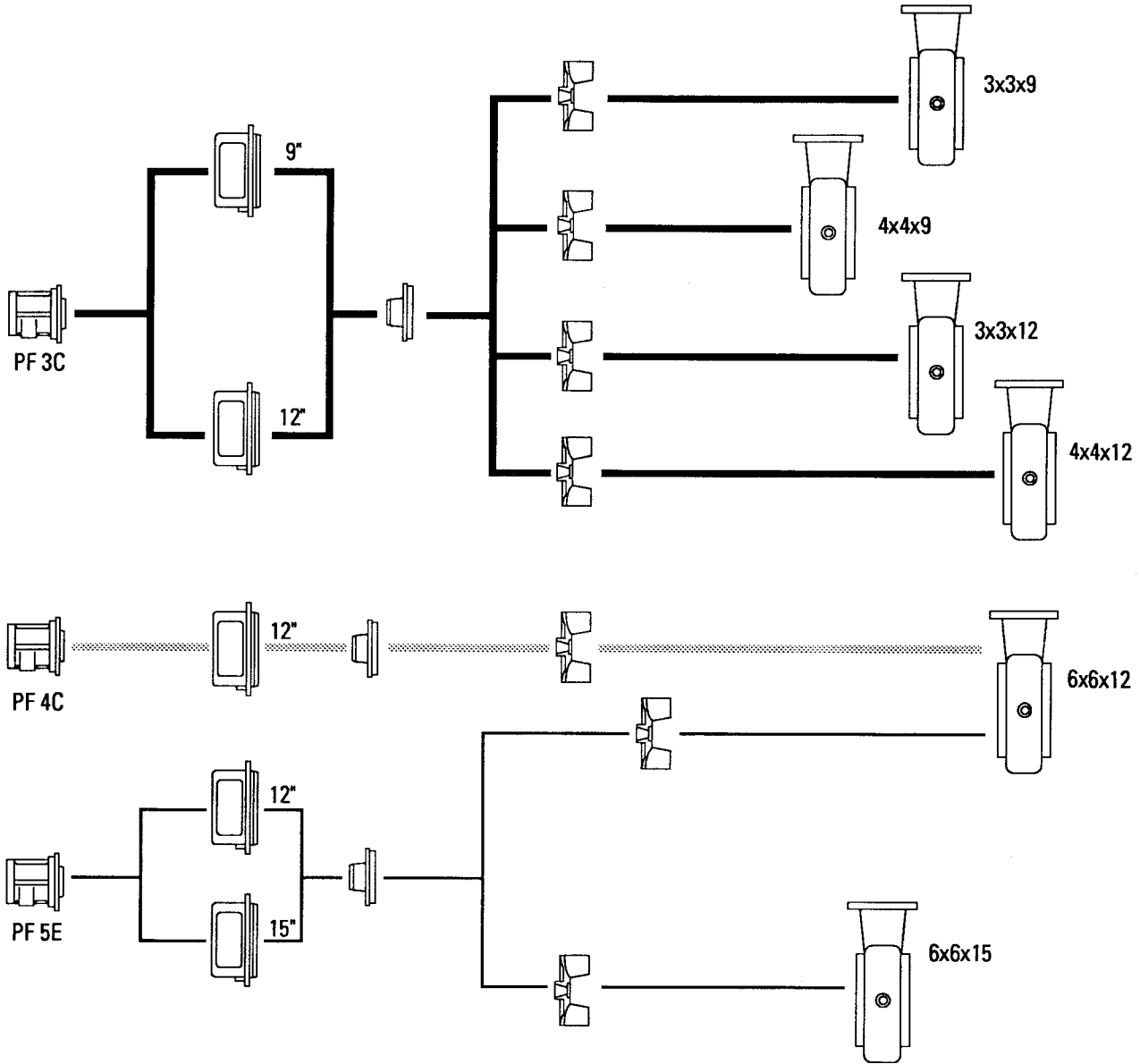

AURORA MODEL 660 PUMP SPLIT PACKING BOX OPTION

SECTION 660 PAGE 165

DATED NOVEMBER 1988

POWER FRAMES 4 & 5 ONLY



Optional Split Packing Box
With Leakage Accumulator
Gland Illustrated

Split packing boxes separate vertically through the packing insert to simplify packing replacement and shaft sleeve inspection. The insert halves are dowed, register aligned and gasketed to prevent leakage. Only six bolts need be removed to expose all of the packing and lantern ring. Remove two more bolts and the remaining packing box insert half can be removed.

The completely exposed packing and sleeve area coupled with the extra large access openings in the pump adapter provides the ultimate in packing accessibility.

Five (5) die-molded, diagonally split, packing rings complete with lantern ring line the stuffing box. The general service packing consists of graphited fiber.

The stuffing box length, bore, sleeve diameters and lantern ring width conform with the recommended standard of the Mechanical Packing Association (MPA).

A tapped opening is provided for lubricating the stuffing box. Lubrication is accomplished by adding grease directly into the lantern ring cavity through a grease fitting or by connecting a by-pass line between the pump discharge and the stuffing box. Automatic grease seals as well as other flushing options are also available.

The standard 450 minimum brinell hardened stainless steel shaft sleeve extends through the entire length of the box and gland and is provided with a snap ring. This snap ring design allows the sleeve and the completely assembled packing box to be removed intact. Reassembly can be accomplished in the same manner. Assemble the complete stuffing box at the convenience of the work bench, install and adjust the packing for proper lubrication leakage (5-10 drops per minute after run-in).

LEAKAGE ACCUMULATOR

POWER FRAMES 4 & 5 ONLY

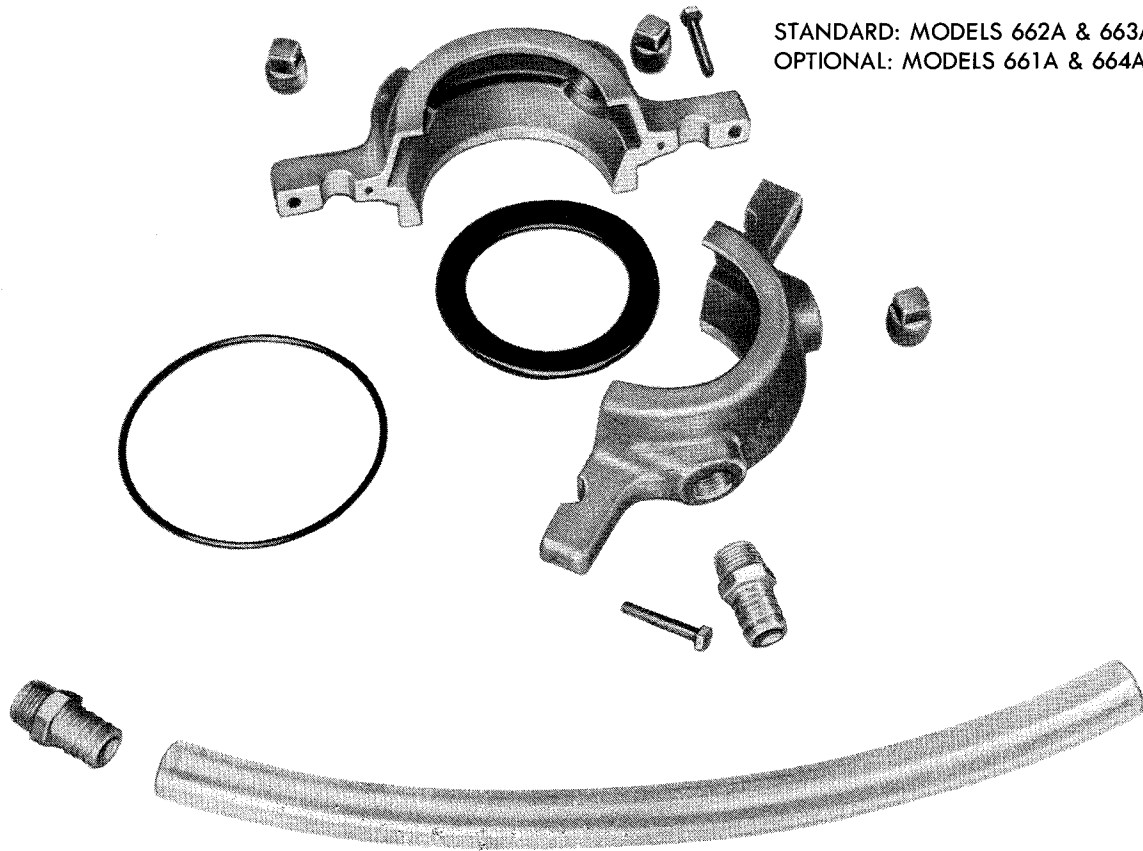

STANDARD: MODELS 662A & 663A
 OPTIONAL: MODELS 661A & 664A

The leakage accumulator gland (sprayless, dripless packing gland) is designed and constructed to prevent the collection of packing leakage in the pump bracket of a vertical or horizontally mounted pump. The leakage accumulator gland has a volute shape with two symmetrical halves. This gland encloses the water slinger preventing any spray from escaping and contaminating the area. The leakage is efficiently directed to a drain connection.

The two gland halves are doweled, bolted together, and sealed at the parting line with a soft liquid sealant. An "O" ring seal between the gland and packing box prevents any leakage in this area. One of the pipe tap ports on the side of the gland is fitted with a hose connector and a clear plastic section of hose, to both drain off and allow visual inspection of the leakage. The remaining ports have pipe plugs, but may be used for maintenance purposes to flush & drain debris from the accumulator.

AURORA MODEL 660 PUMP OPTIONS

SECTION 660 PAGE 167

DATED NOVEMBER 1988

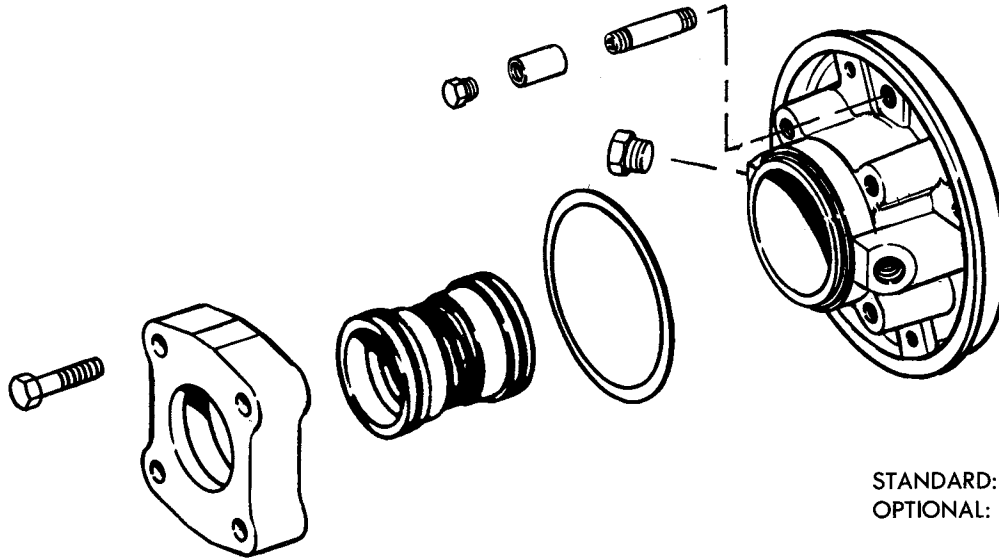

STANDARD: MODEL 664A
OPTIONAL: MODELS 661A, 662A & 663A

Double mechanical seals are recommended for gritty or abrasive applications. Seal faces are protected by clear water under pressure, injected directly into the seal cavity. Pressure in the seal box must be fifteen (15) lbs. higher than the operating pressure at the stuffing box of the pump. This forces the inner sealing faces closed and provides both faces with a film of clear sealant. If this is not done, abrasive particles may be forced under the sealing faces hastening wear. Even when the pump is not running, a pressure differential, or at least equal pressure in the seal box, is desirable. The sealant circulation for most pumping operations may be dead ended in the stuffing box. Pressures over 30 psi or RPM of 1200 max. require constant circulation to prevent overheating.

The seal box is designed for the compressed seal length and does not require any adjustments. The seal housing is extra large to provide excellent circulation of clear sealing liquid. The housing also has two tapped openings 180° apart for the flushing connections.

The standard shaft sleeve design is provided with a snap ring which allows the sleeve and the completely assembled seal box to be removed intact. Reassembly can be accomplished in the same manner. Assemble the complete seal box at the convenience of the work bench and install.

SLEEVES

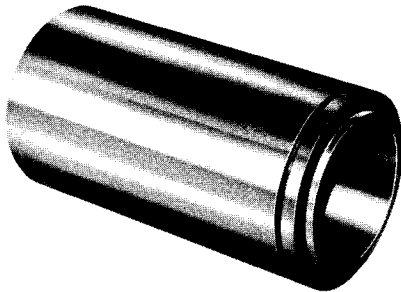

Shaft sleeves, machined to close tolerances are optionally available in either bronze, 316 stainless steel, or monel.

SHAFTS

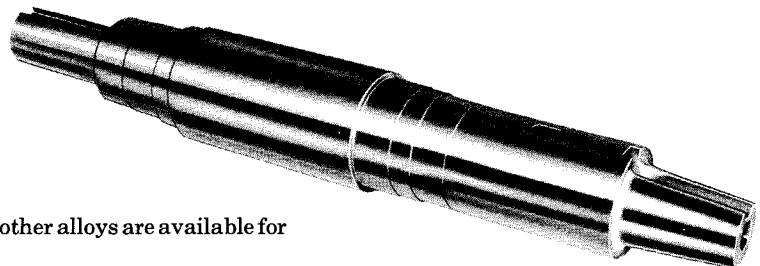

Precision machined shafts of stainless steel, monel and other alloys are available for difficult application.

AURORA MODEL 662A PUMP 3" & 4" PUMPS

SECTION 660 PAGE 203
DATED NOVEMBER 1988
SUPERSEDES PAGE 203
DATED JUNE 1983

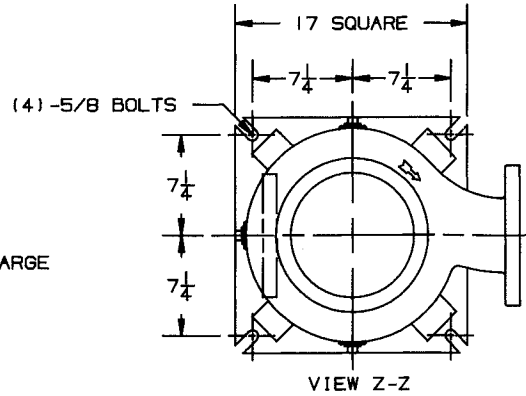
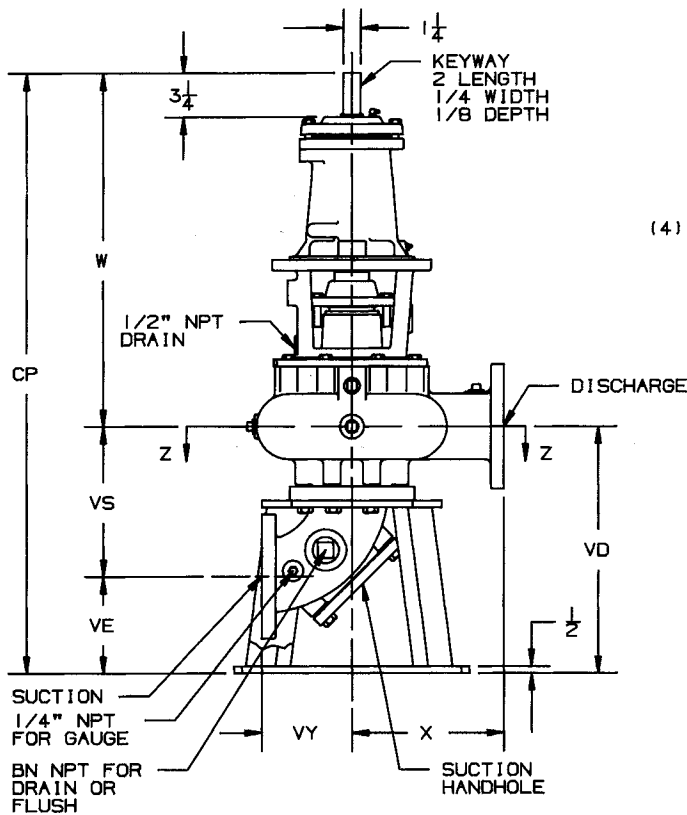

- NOTES:
1. ALL DIMENSIONS IN INCHES.
 2. DIMENSIONS MAY VARY ± 1/4".
 3. NOT FOR CONSTRUCTION PURPOSES UNLESS CERTIFIED.
 4. TWO (2) 1/2" NPT CONNECTIONS 180° APART, ON THE STUFFING BOX FOR LUBRICATION PURPOSES ARE FURNISHED AS STANDARD. ON PACKED PUMPS AN ALEMITE FITTING IS PROVIDED IN ONE TAP AND THE REMAINING TAP IS PLUGGED.
 5. DISCHARGE POSITION 1 IS FURNISHED AS STANDARD UNLESS SPECIFIED.
 6. SUCTION AND DISCHARGE FLANGES ARE AMERICAN STANDARD 125 LBS.

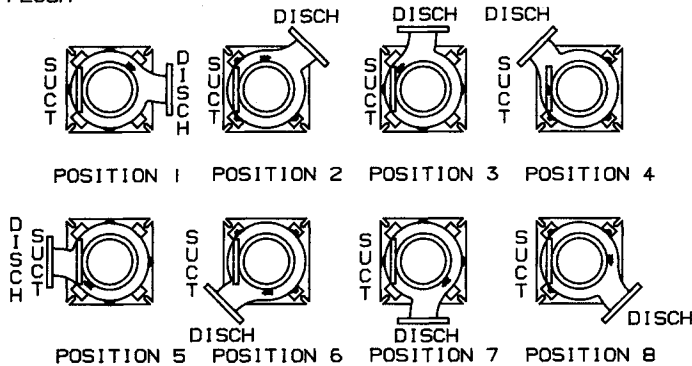

DISCHARGE POSITIONS AVAILABLE
(VIEW Z-Z)

NOTE:
PUMP SIZES 3x3x9 AND 3x3x12 DISCHARGE POSITIONS AVAILABLE ONLY IN 1, 3, 5, AND 7.

DISCH SUCTION CASE BORE	POWER FRAME	BN	VY	W	X	CP	VD	VE	VS
3x3x9	3C	1	6 1/2	25 1/2	10	41 7/8	16 3/8	6 3/4	9 5/8
3x3x12	3C	1	6 1/2	25 5/8	13	42	16 3/8	6 3/4	9 5/8
4x4x9	3C	1 1/2	6 1/2	26 1/2	11	43 3/8	16 7/8	6 15/16	9 15/16
4x4x12	3C	1 1/2	6 1/2	26 5/8	13	43 1/2	16 7/8	6 15/16	9 15/16

AURORA MODEL 662A PUMP 6" PUMPS

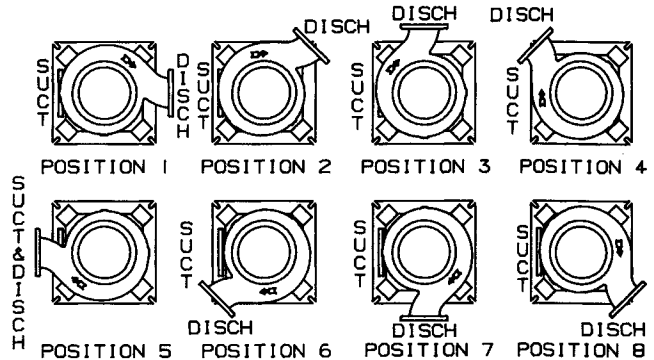
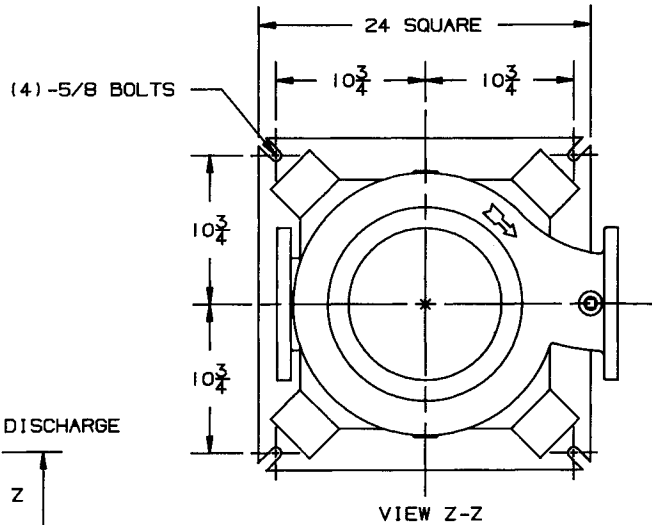
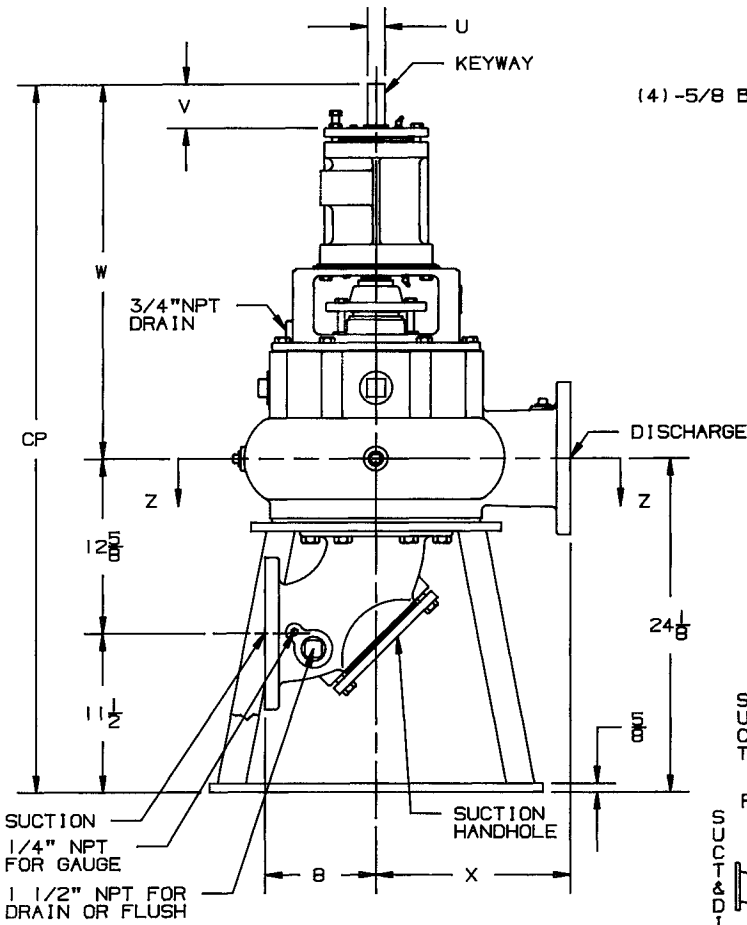

DISCHARGE POSITIONS AVAILABLE
 (VIEW Z-Z)

- NOTES:
 1. ALL DIMENSIONS IN INCHES.
 2. DIMENSIONS MAY VARY $\pm 1/4$ ".
 3. NOT FOR CONSTRUCTION PURPOSES UNLESS CERTIFIED.
 4. TWO (2) 1/2" NPT CONNECTIONS 180° APART, ON THE STUFFING BOX FOR LUBRICATION PURPOSES ARE FURNISHED AS STANDARD. ON PACKED PUMPS AN ALEMITE FITTING IS PROVIDED IN ONE TAP AND THE REMAINING TAP IS PLUGGED.
 5. DISCHARGE POSITION 1 IS FURNISHED AS STANDARD UNLESS SPECIFIED.
 6. SUCTION AND DISCHARGE FLANGES ARE AMERICAN STANDARD 125 LBS.

POWER FRAME	U	V	KEYWAY		
			LENGTH	WIDTH	DEPTH
4C	1 1/4	3 3/16	2	1/4	1/8
5E	2 3/8	6 3/8	4	5/8	5/16

DISCH SUCT CASE BORE	POWER FRAME	W	X	CP
6x6x12	4C	27 1/8	14	51 1/4
6x6x12	5E	38 1/8	14	62 1/4
6x6x15	5E	38 1/8	16	62 1/4

AURORA MODEL 662A PUMP

3" & 4" PUMPS FLEXIBLE SHAFT

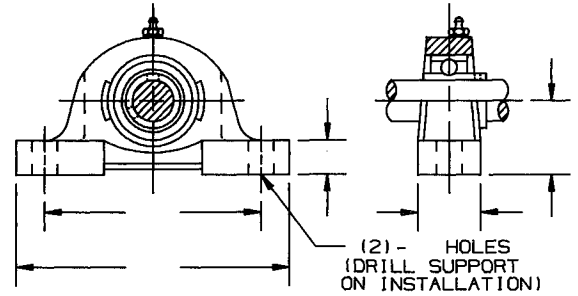
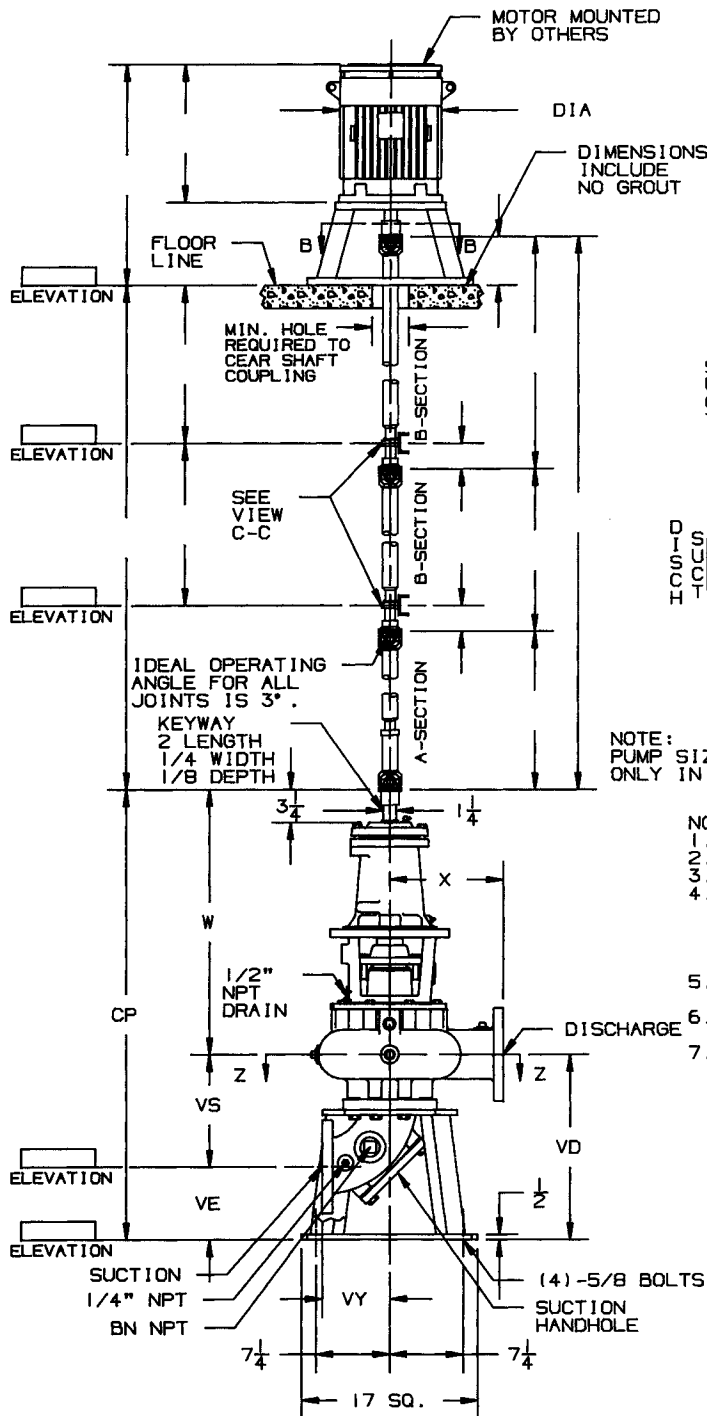

VIEW C-C
STEADY BEARINGS

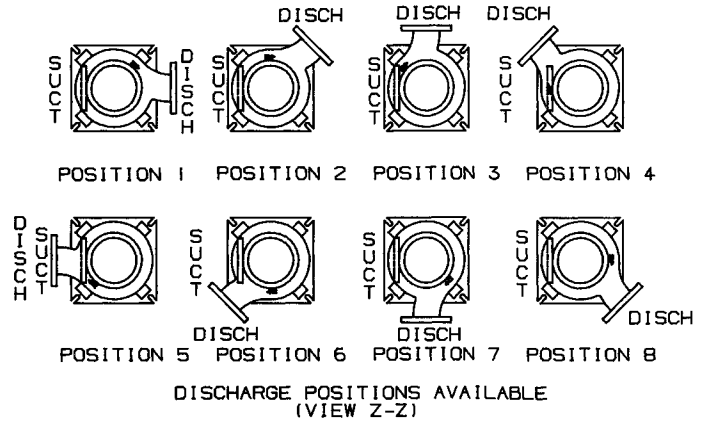

NOTE:
PUMP SIZES 3x3x9 AND 3x3x12 DISCHARGE POSITIONS AVAILABLE ONLY IN 1, 3, 5, AND 7.

NOTES:

1. ALL DIMENSIONS IN INCHES.
2. DIMENSIONS MAY VARY $\pm 1/2"$.
3. NOT FOR CONSTRUCTION PURPOSES UNLESS CERTIFIED.
4. TWO (2) 1/2" NPT CONNECTIONS 180° APART, ON THE STUFFING BOX FOR LUBRICATION PURPOSES ARE FURNISHED AS STANDARD. ON PACKED PUMPS AN ALEMITE FITTING IS PROVIDED IN ONE TAP AND THE REMAINING TAP IS PLUGGED.
5. DISCHARGE POSITION 1 IS FURNISHED AS STANDARD UNLESS SPECIFIED.
6. SUCTION AND DISCHARGE FLANGES ARE AMERICAN STANDARD 125 LBS.
7. CONDUIT BOX IS SHOWN IS APPROXIMATE LOCATION. DIMENSIONS ARE NOT SPECIFIED AS THEY MAY VARY WITH EACH MOTOR MANUFACTURER.

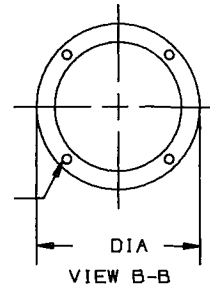

DISCH	SUCT	CASE	BORE	POWER	FRAME	BN	VY	W	X	CP	VD	VE	VS
3x3x9	3C	1	6 1/2	25 1/2	10	41 7/8	16 3/8	6 3/4	9 5/8				
3x3x12	3C	1	6 1/2	25 5/8	13	42	16 3/8	6 3/4	9 5/8				
4x4x9	3C	1 1/2	6 1/2	26 1/2	11	43 3/8	16 7/8	6 15/16	9 15/16				
4x4x12	3C	1 1/2	6 1/2	26 5/8	13	43 1/2	16 7/8	6 15/16	9 15/16				

AURORA MODEL 662A PUMP

6" PUMPS

FLEXIBLE SHAFT

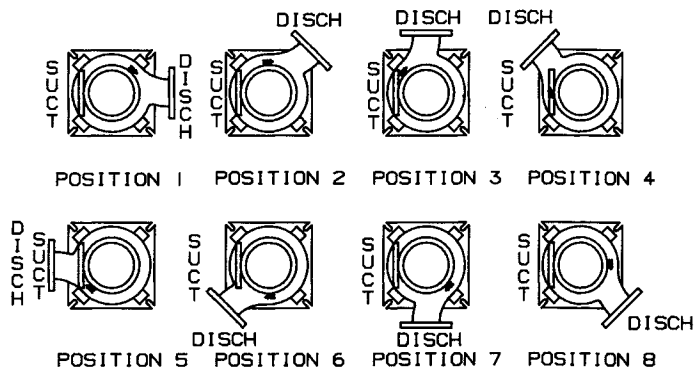
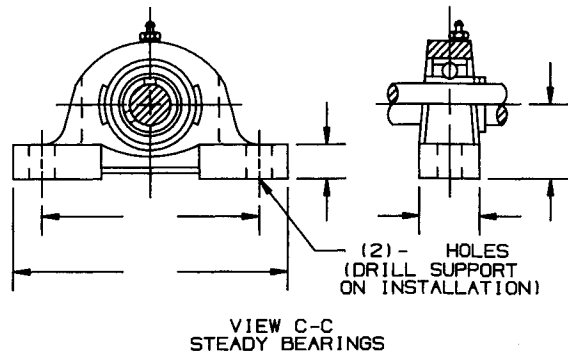
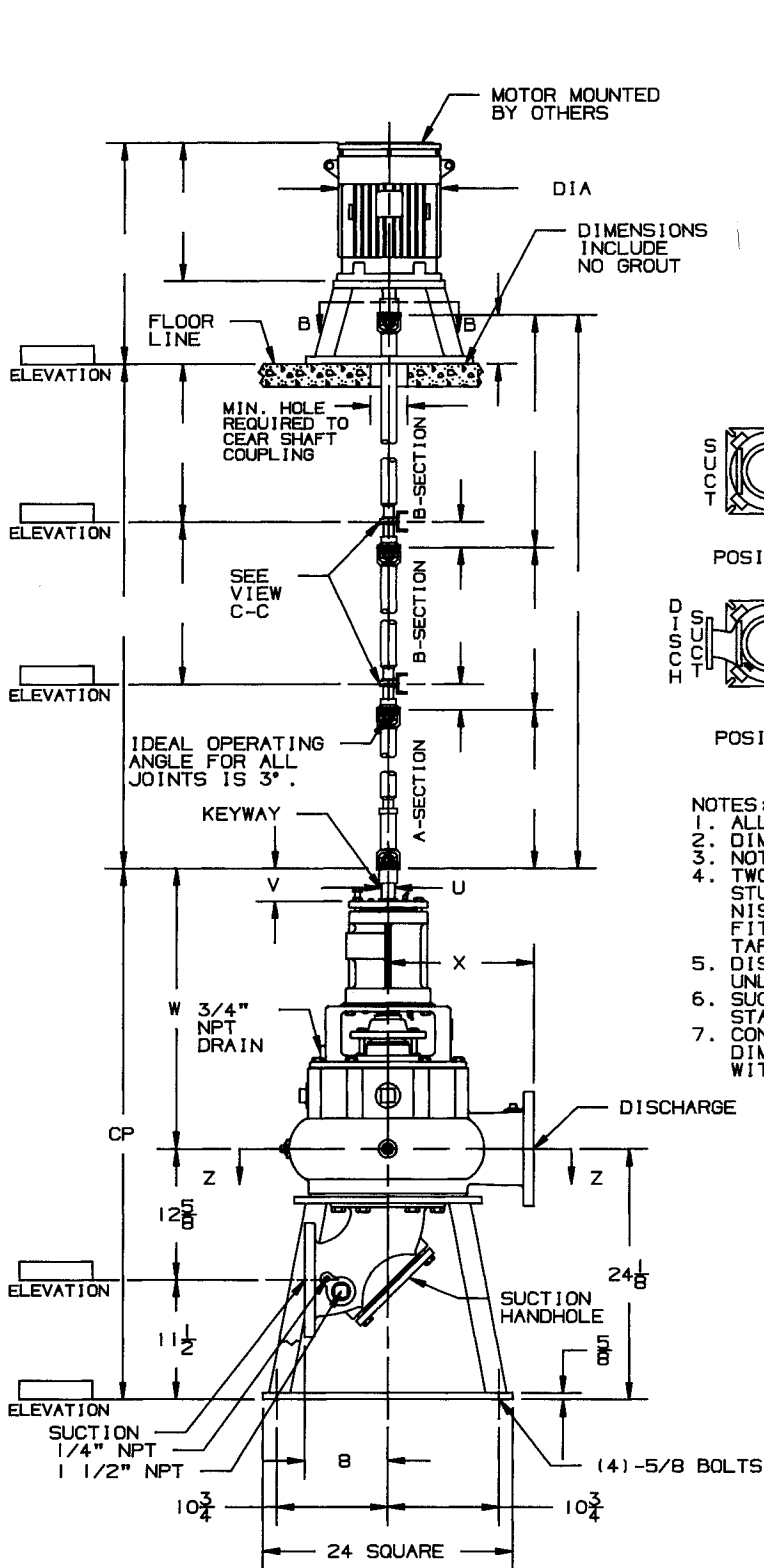

DISCHARGE POSITIONS AVAILABLE
(VIEW Z-Z)

- NOTES:
1. ALL DIMENSIONS IN INCHES.
 2. DIMENSIONS MAY VARY $\pm 1/2"$.
 3. NOT FOR CONSTRUCTION PURPOSES UNLESS CERTIFIED.
 4. TWO (2) 1/2" NPT CONNECTIONS 180° APART, ON THE STUFFING BOX FOR LUBRICATION PURPOSES ARE FURNISHED AS STANDARD. ON PACKED PUMPS AN ALEMITE FITTING IS PROVIDED IN ONE TAP AND THE REMAINING TAP IS PLUGGED.
 5. DISCHARGE POSITION 1 IS FURNISHED AS STANDARD UNLESS SPECIFIED.
 6. SUCTION AND DISCHARGE FLANGES ARE AMERICAN STANDARD 125 LBS.
 7. CONDUIT BOX IS SHOWN IS APPROXIMATE LOCATION. DIMENSIONS ARE NOT SPECIFIED AS THEY MAY VARY WITH EACH MOTOR MANUFACTURER.

(4) DRILLS ON DIA. FOR FOUNDATION BOLTS.

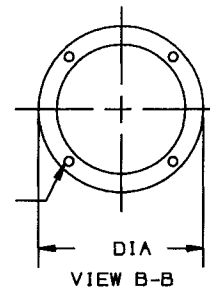

POWER FRAME	U	V	KEYWAY		
			LENGTH	WIDTH	DEPTH
4C	1 1/4	3 3/16	2	1/4	1/8
5E	2 3/8	6 3/8	4	5/8	5/16

DISCH	SUCT	CASE BORE	POWER FRAME	W	X	CP
6x6x12	12	4C	27 1/8	14	51 1/4	
6x6x12	5E	38 1/8	14	62 1/4		
6x6x15	5E	38 1/8	16	62 1/4		

AURORA SERIES 660 SELECTION CHART 885 R.P.M. VORTEX IMPELLER

