

ap

AURORA PUMP A member of PENTAIR PUMP GROUP

AURORA PUMP

BULLETIN 6301

**630 SERIES
SINGLE STAGE
SEWAGE
PUMPS**

CAPACITIES TO 1000 G.P.M.
HEADS TO 80 FEET
TEMPERATURES TO 140°F.
DISCHARGE SIZES 4" AND 6"

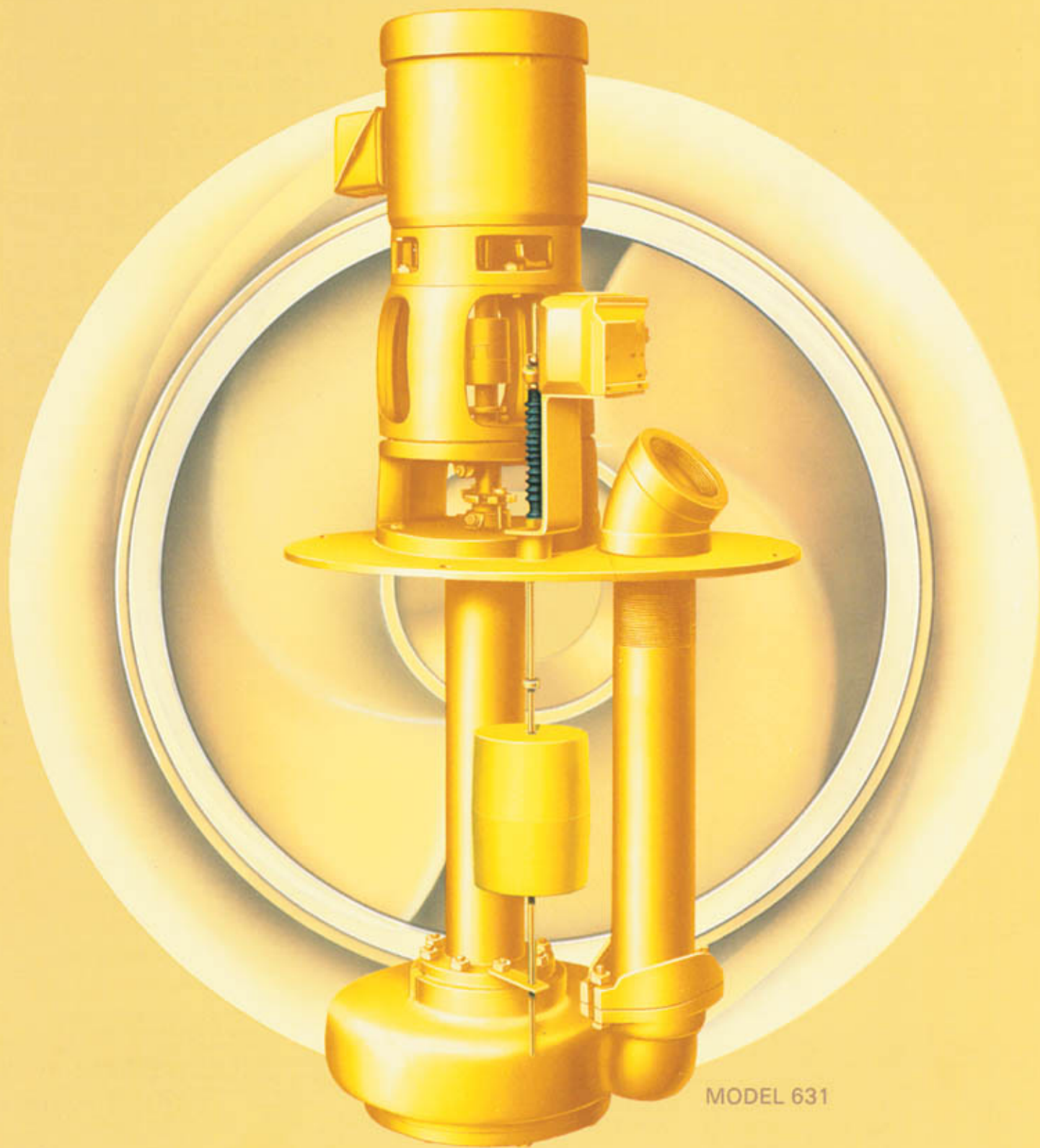

MODEL 631

INTRODUCTION AURORA 630 SERIES PUMPS

Water pollution and its effect on our environment is on everyone's mind. This is particularly true today and for the future generations. The population explosion along with a broader understanding of the water pollution problem has brought about the need for more and better sewage treatment facilities. The installations of today and tomorrow demand more reliable sewage pumping equipment. Longer life has become essential to over-all pump performance. Aurora Pump recognizes this need, and with this bulletin offers the 630 Series of heavy duty vertical wet pit non-clog pumps as our solution to your sewage pumping problems. Contact your Aurora Pump representative for added details.

1 MOTOR MOUNTING bracket that assures alignment of motor and pump shaft with tongue and groove machining. Motors are of standard "HP" manufacture. **2 EXTERNAL IMPELLER ADJUSTMENT** is accomplished with hexagon shaped adjusting nut. A lock nut secures the bearing collar to the shaft. **3 THRUST BEARING** is regreaseable and is protected from contamination by grease seals on both sides and a water slinger. The bearing is elevated



6" above the floor level for easy servicing and added protection from washdown, flooding, etc. **4 STUFFING BOX** is standard with packing, lantern ring, and a split gland for gastight construction. The lantern ring can also be used for packing lubrication from an external source. **5 STEEL OVAL BASEPLATE** is standard and eliminates removing the complete cover plate. **6 ELEVATED FLOAT SWITCH ASSEMBLY** is standard. Several enclosures are available. Refer to page 6 for additional details. **7 BEARING ASSEMBLIES** available in several arrangements and materials to suit difficult applications. Line bearings are provided on 6'-2" settings and deeper. One bearing is provided for each additional 5' of setting. All the standard bearings are grease lubricated. **8 POSITIVE ALIGNMENT THROUGHOUT** utilizes tongue and groove registered design. **9 PUMP SHAFT** 1-7/16" in diameter is provided to minimize deflection and bearing wear. **10 LIQUID END** includes a non-clog impeller as standard and will PASS a 3 INCH SPHERE. **11 DISCHARGE PIPE** is securely locked to the baseplate. A 45° elbow is threaded for easy system piping. A below surface discharge is optionally available.

QUICK REFERENCE 630 SERIES FEATURE SELECTOR

STANDARD

- Bronze fitted construction
- Bronze pump bearings
- Bronze line bearings (6'-2" settings and deeper)
- Dynamically balanced non-clog impeller passes 3" sphere
- Elevated regreaseable thrust ball bearing
- Grease lubricated pump and line bearings
- Standard "HP" base motors
- Carbon steel shaft
- Packing box with split gland and lantern ring
- Oval baseplate
- Gastight construction
- 4" Vent — 34" baseplate and larger
- Float switch
- Plastic float and rod
- Elevated switch support
- External adjustment of impeller
- Pump setting increments of 6"
- Pump settings up to 15'-8"

OPTIONAL

- All iron or all bronze construction
- Bronze impeller
- Various pump and line bearing types
- Drip oiler for line bearings
- Solenoid oiler for line bearings
- Stainless steel shaft
- Round, square or special baseplates
- Steel curb rings
- Various float switch enclosures
- Electric alternator
- Stainless steel or bronze float and rod
- High water alarm
- Alarm bells and horns
- Float guard
- 4" Vent — 28" baseplate and smaller
- Flushing lines to sleeve bearings
- Electric controllers
- Special pump setting increments
- Pump settings over 15'-8"
- Suction cover wear ring

RANGE CHARTS AND ENGINEERING DETAILS

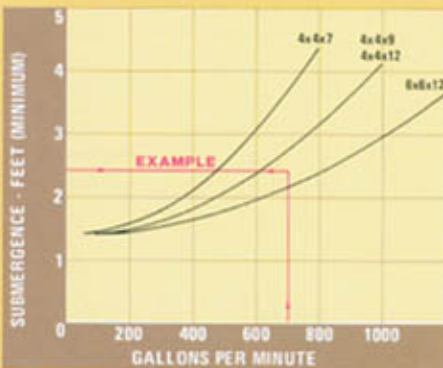
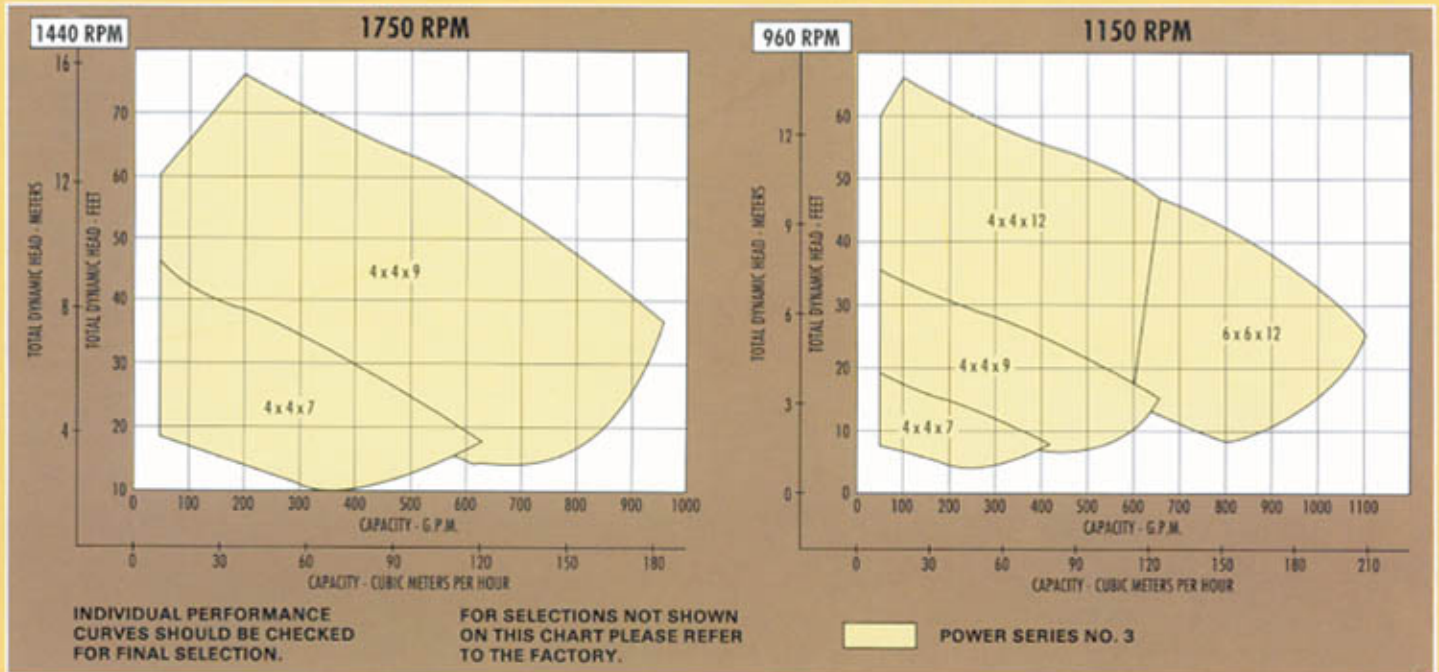

Air may be entrained in the pumped liquid if the pump suction is located too close to the free liquid surface in the suction source. Pumping liquid with entrained air can cause a reduction of capacity, vibration, loss of efficiency and wasted power. Excessive wear of close running parts, bearing stresses

and shaft damage are also subsequent effects. If the capacity in gallons per minute and the pump size are known, the minimum height of the liquid above the suction inlet (submergence) can be determined. A properly designed suction inlet and sump can be accomplished with the help of the submergence chart.

EXAMPLE

The recommended minimum submergence for a 4"x4"x9" Model 630 pump operating at 700 gallons per minute (G.P.M.), from water level to suction flange is 2.4 feet.

STANDARD MATERIAL OF CONSTRUCTION

DESCRIPTION	MATERIAL
BASEPLATE	STEEL-WRT
PUMP BEARING	BRONZE ASTM B62
BEARING COLLAR	BRONZE ASTM B62
CASING	CAST IRON ASTM A48
DISCHARGE PIPE	STEEL WRT. SCH'D. 40
HEAD-LOWER	CAST IRON ASTM A48
HEAD-UPPER	CAST IRON ASTM A48
IMPELLER	CAST IRON ASTM A48
PACKING	GRAPHITED FIBER
SHAFT	STEEL AISI C1040
SUCTION COVER	CAST IRON ASTM A48
SUPPORT PIPE	STEEL WRT. SCH'D. 40

INTERMEDIATE LINE SHAFT BEARINGS

PIT DEPTHS	PUMP SETTING	NO. OF LINE SHAFT BRG.
6'-6"	6'-2"	1
11'-6"	11'-2"	2
16'-6"	16'-2"	4

PIT DEPTH OR PUMP SETTING (APPROX.)

LENGTH IN FT.		LENGTH IN FT.		LENGTH IN FT.	
PIT DEPTH	PUMP SETTING	PIT DEPTH	PUMP SETTING	PIT DEPTH	PUMP SETTING
2'	1'-8"	7'	6'-8"	12'	11'-8"
2'-8"	2'-2"	7'-6"	7'-2"	12'-6"	12'-2"
3'	2'-8"	8'	7'-8"	13'	12'-8"
3'-6"	3'-2"	8'-6"	8'-2"	13'-6"	13'-2"
4'	3'-8"	9'	8'-8"	14'	13'-8"
4'-6"	4'-2"	9'-6"	9'-2"	14'-6"	14'-2"
5'	4'-8"	10'	9'-8"	15'	14'-8"
5'-6"	5'-2"	10'-6"	10'-2"	15'-6"	15'-2"
6'	5'-8"	11'	10'-8"	16'	15'-8"
6'-6"	6'-2"	11'-6"	11'-2"	REFER TO FACTORY	

DESIGN DETAILS

AREA	DESCRIPTION	POWER SERIES 3
PUMP SHAFT	DIAMETER AT IMPELLER	1 1/4"
	DIAMETER BETWEEN COUPLING AND IMPELLER	1 7/8"
	DIAMETER AT COUPLING END	1 1/4"
BEARINGS	BEARING (BALL) — HEAD	311
	BEARING (SLEEVE) — PUMP	6" LG
SUPPORT PIPE SIZE		4"
POWER SERIES		3

LIMITATIONS

MAXIMUM LIMITATIONS BASED ON STANDARD MATERIALS AND PUMPING CLEAR WATER		
SPEED — R.P.M.		1750
MINIMUM HORSEPOWER	1750 R.P.M.	1
	1150 R.P.M.	3/4
TEMPERATURE °F.		140
BASIN PRESSURE — P.S.I.		2
BASIN COVER SIZE	W/O OVAL OR MANHOLE	28
	W OR W/O OVAL OR MANHOLE	78

Sewage Ejectors are required for handling sewage and other liquids that contain solids and unscreened wastes where gravity drainage is impossible or impractical. Maximum dependability and performance is assured by calculations and selection of the system components. Information required for selecting pump capacity includes the number and type of fixtures, and type of facilities serviced. Elevation to the highest point of discharge and friction losses in the piping system determines the pump discharge head required. Tank or basin size is calculated from the pump capacity requirement.

IMPORTANT NOTE: According to the National Plumbing Code, a Duplex Sewage Ejector is required whenever the pit or basin services more than 6 toilets. Each pump in a duplex system must be large enough to handle the entire flow by itself. This is a safety precaution in the event of failure of one of the pumps. **PUMPS THAT HANDLE 3" SOLIDS ARE RECOMMENDED.**

DETERMINING PUMP CAPACITY: A simplified procedure in the selection of sewage ejectors places all types of buildings into a single classification with the capacity of the pump determined by the number of toilets serviced (see table). In addition, the minimum velocity required to keep solids moving through the pipe lines must be considered. A pump capacity of less than 50 gallons per minute in a 4" pipe line or 100 gallons per minute in a 6" pipe line would permit solids to settle out.

MAX. NO. OF TOILETS	1	3	5	7	11	15	21	26
	or	or	or	or	or	or	or	or
GALLONS PER MINUTE (G.P.M.)	75	100	125	150	200	250	300	350

ADDITIONAL WATER DRAINAGE: Under normal conditions there will also be clear water drainage from fixtures such as sinks, lavatories, floor drains, etc. This drainage into the sewage ejector basin is highly desired to dilute the raw sewage so that it

may be more easily handled. In establishing the capacity recommendations in the above chart, an allowance for fixtures up to four times the number of toilets is included. Where the number of fixtures exceeds that allowance, 3 gallons per minute for each additional fixture must be added to the pump capacity.

EXAMPLE A:

Capacity of 5 toilets	125 G.P.M.
No. of fixtures to be handled in addition to toilets	25
Deduct number of fixtures that can be handled by pump (4 times no. of toilets) (4 × 5 toilets)	20
Excess fixtures	5
fixtures @ 3 G.P.M. each =	15 G.P.M.
Total capacity required	140 G.P.M.

WATER SEEPAGE: Water seepage in amounts up to 50% of the sewage capacity can be safely handled by sewage ejectors selected on the basis of the above chart. Where seepage exceeds 50%, the additional amount must be added to the pump capacity to determine the required pump size. Water seepage delivered to the sewage basin through drain tile from drainage beds will vary according to local soil conditions. As a guide to safe calculations, the following may be used: a) Sandy Soil-14 G.P.M. per 1000 sq. ft. of bed; b) Clay Soil-8 G.P.M. per 1000 sq. ft. of bed.

EXAMPLE B:

Total sewage and clear water drainage from fixtures	140 G.P.M.
Water seepage	80 G.P.M.
Allowance for handling seepage up to 50% of sewage total	70 G.P.M.
Additional capacity required	10 G.P.M.
Total pump capacity required	150 G.P.M.

UNUSUAL ADDITIONAL SERVICE FLOW: Careful consideration should be given to real or potential additional flow from unusual or abnormal additions to the service flow as determined by the method of calculation outlined above. This would include flow from such services as boiler drainage, air conditioning drainage water, etc. All of this service flow must be added to the projected pump capacity requirement.

DETERMINING PUMP DISCHARGE HEAD: The pump discharge head may be calculated by determining the distance from the lowest level of water in the basin to the street level. By using the street level in place of the sewer line as point of reference, a reasonable factor of safety is established, accounting for the possibility of back pressure.

To this you must add the friction loss in the discharge pipe line and fittings.

EXAMPLE C:

Distance from lowest level of water to street level	26 ft.
Friction of discharge pipe (150 G.P.M. 4" pipe 150' long)	2 ft.
Friction of pipe fittings (elbows, check valves, gate valves, Y-branch, etc.)	2 ft.
Total discharge head	30 ft.

DETERMINING TANK OR BASIN SIZE: The size of the sewage basin should be selected to prevent both short cycling of the pumping operation and excessive settling out of solids. A drawn down ratio of 3:1 is recommended... this means that the basin volume between the low sewage level and the high sewage level should accommodate 3 times the capacity of the pump before the pumping cycle begins. A minimum distance of 1 foot between the lowest sewage level and the basin floor should be allowed. In addition, the distance between the maximum sewage level and the basin cover should be $\frac{1}{3}$ of the storage volume between the high and low sewage levels, but not less than 2 feet. Where conditions limit the basin depth, the required capacity may be obtained by using a larger basin diameter.

EXAMPLE D:

Total pump capacity	150 G.P.M.
Basin to hold 3 times pump capacity (3 × 150 Gal.)	450 Gal.
From table below a 48" dia basin will hold 95 Gal. per foot of depth. Therefore, basin depth is (450 ÷ 95)	4.74 ft.
Add approx. $\frac{1}{3}$ to depth for storage between high level of sewage and basin cover or (minimum 2 ft.)	2.00 ft.
Add approx. 1 ft. to depth for distance between lowest level of sewage and basin floor	1.00 ft.
Total pit depth required	7.74 ft.
Recommended pit depth (next standard 6" increment)	8 ft.

CALCULATING ROUND TANK OR BASIN CAPACITIES Per Foot of Depth:

PUMP	SIMPLEX				DUPLEX			
BASIN DIA. INCHES	24	30	36	42	48	54	60	72
CAPACITY PER FOOT IN GALLONS	24	38	53	77	95	119	150	212

NOTE: TANKS ARE AVAILABLE IN DEPTHS OF 6" INCREMENTS.

CALCULATING SQUARE PIT CAPACITIES:

To determine the size of a square or rectangular pit commonly used in concrete construction the same procedure as outlined in example D may be followed. To calculate the capacity of a pit other than a round one, use the following formula: Cubic content in cu. ft. × 7.48 = the number of gallons.

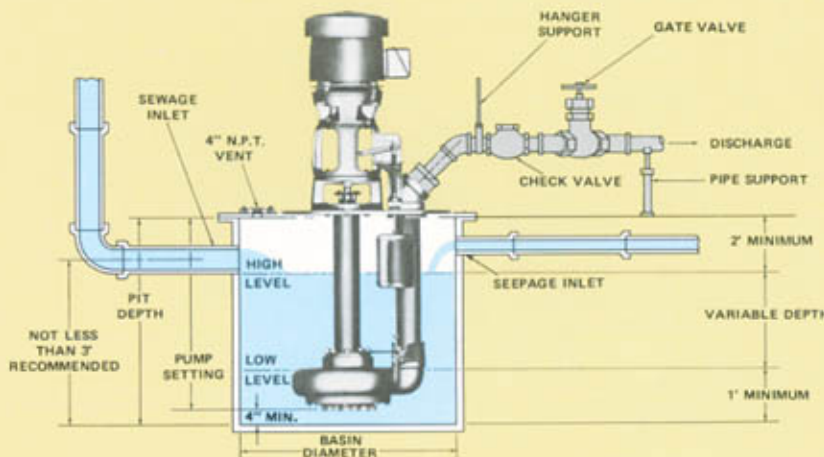

TYPICAL INSTALLATION

The piping layout shown here is of a conventional installation. Specific applications accommodating the individual service conditions, basin capacity, etc., will be reflected in change in diameter sizes of the basins and covers along with the basin depth.

PUMP FEATURES

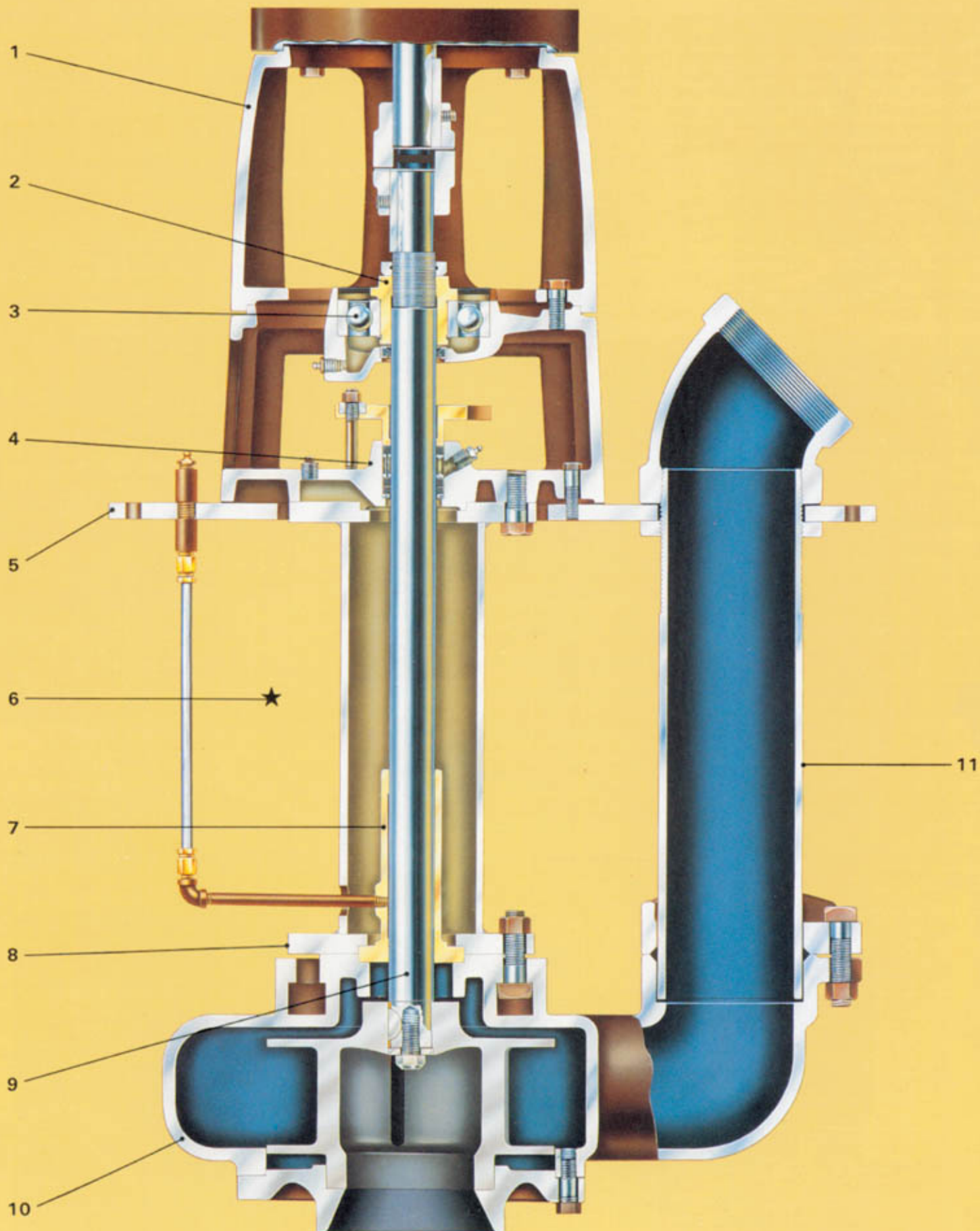

ENGINEERING SPECIFICATIONS AND DIMENSIONS

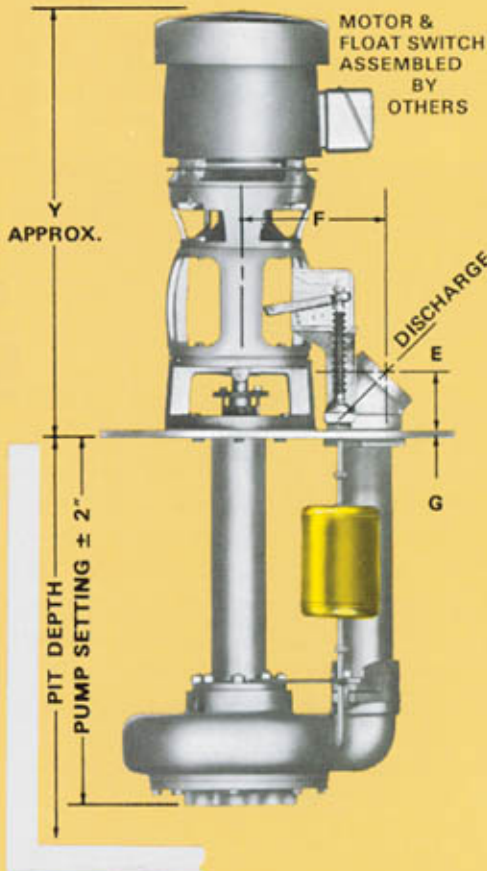
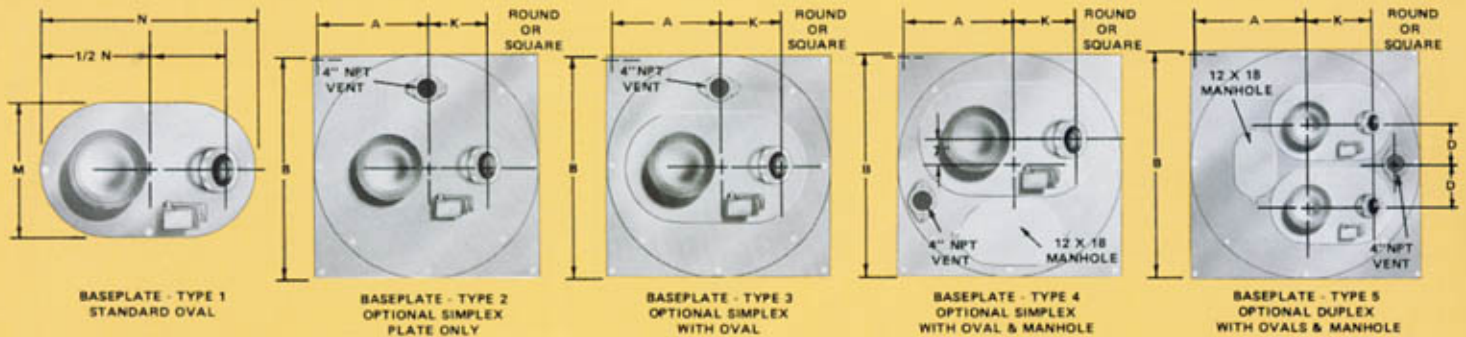

NOTES:
 1. Dimensions and weights are approximate.
 2. All dimensions are in inches and may vary $\pm \frac{1}{8}$ ".
 3. Frame sizes, "Y" dimension and motor weight are for open drip-proof motors only.
 4. Conduit box is shown in approximate position. Dimensions are not specified as they vary with each motor manufacturer.

5. Add pump(s), base(s), upper head(s) and motor weight(s) for unit weight.
 6. Not for construction purposes unless certified.
 7. Motor H.P. will increase due to friction when multiple line shaft bearings are used.
 8. Refer to factory for float suitability for liquids other than water.

BASEPLATE — OVAL — STEEL					
NO.	TYPE	G	M	N	WGT
1	20 x 24	3/4	20	24	36
2	22 x 28	1/2	22	28	63

BASEPLATES — ROUND OR SQUARE — STEEL													
		TYPE 2			TYPE 4			TYPE 5					
A	K	OVAL NO.	RD.	WT.	OVAL NO.	RD.	WT.	OVAL NO.	RD.	WT.			
11	24	N.A.	N.	41	34								
12	28	N.A.	N.	58	26								
15	24	1	N.	89	123								
18	40	2	N.	128	183	1	N.	128	123		243	209	
22	48	2	N.	225	299	2	N.	225	299	1	243	209	
25 1/2	52	2	N.	302	387	2	N.	312	387	2	N.	307	304
29	60	2	N.	407	523	2	N.	407	523	2	N.	507	542
32	66	2	N.	580	755	2	N.	603	755	2	N.	728	827
36	78	2	N.	832	1080	2	N.	842	1075	2	N.	1018	1290

FRAME	HORSEPOWER		MOTOR WGT (LBS)	UPPER HEAD WGT (LBS)	Y APPROX
	1750	1150			
143 HP	1	3/4	40	21	25
145 HP	1 1/2	2	45	21	26
182 HP	3	1 1/2	72	21	27
184 HP	5	2	80	21	28
213 HP	7 1/2	3	130	21	30
215 HP	10	5	145	21	32
254 HP	15	7 1/2	220	21	34
256 HP	20	10	240	21	36
284 HPH	25	15	330	42	39

PUMP SIZE			PUMP WGT. IN LBS.			FOR EA. ADD. 1' SETTING			MINIMUM BASEPLATE SIZE								
DISCH.	SUC. TION	CASE BORE	5'-8" SETTING	D	E	F	TYPE 1 SIZE	TYPE 2 SIZE	*TYPE 3 SIZE	**TYPE 4 SIZE	TYPE 5 SIZE						
4	4	7	542	30	10 1/2	4 1/2	11 1/2	20 x 24	9 1/2	24	9 1/2	34	9 1/2	40	9 1/2	46	12 1/2
4	4	9	562	30	10 1/2	4 1/2	11 1/2	20 x 24	9 1/2	24	9 1/2	34	9 1/2	40	9 1/2	46	12 1/2
4	4	12	610	30	11 1/2	4 1/2	11 1/2	22 x 28	8 1/2	34	9 1/2	36	8 1/2	42	8 1/2	53	11 1/2
6	6	12	655	30	11 1/2	6	13 1/2	22 x 28	10 1/2	34	11	36	10 1/2	42	10 1/2	53	13

*All bases 36" and larger — use 22 x 28 oval only. **All bases 42" and larger — use 22 x 28 oval only.

The contractor shall furnish (and install as shown on the plans) Aurora Model (631 Simplex) (632 Duplex) centrifugal sewage pumps size . . . x . . . of (bronze fitted) (all iron) construction. Each pump shall have a capacity of . . . G.P.M. at . . . ft. total head, with a temperature of . . . °F. . . specific gravity. The units shall be designed for a sump depth of . . . feet and shall be furnished with an (above the floor discharge terminating at the baseplate with a 45° threaded elbow) (below the floor discharge terminating with a threaded connection). A steel baseplate; (oval); (round) (square) — (Simplex) (Simplex with oval) (Simplex with oval and manhole) (Duplex with ovals and manhole) will be provided. A 4" vent will be provided on all round or square baseplates. The pump casing and suction cover shall be cast iron. The casing is to be provided with a cast integral discharge elbow. The cast iron impeller is of the enclosed non-clog type and shall be capable of passing a 3" diameter sphere. The impeller running clearances will be of the face

to provide simple adjustments axially to compensate for wear. The impeller is to be dynamically balanced and keyed to the pump shaft. The column pipe must be 4" diameter having machined tongue and grooved joints to insure shaft alignment. A pump bearing will be located directly above the impeller and shall be (bronze sleeve) (iron sleeve) or relief type with (iron) (bronze) (cutless rubber) bushing. Spool bearing with steel housing with (iron) (bronze) (cutless rubber) bushing. Line bearings must be provided with a setting of 6"-2" and one bearing for each additional 5' of setting thereafter. All standard sleeve or relief pump and line bearings must be (grease) (oil) (water) lubricated through separate Nylon tube lubrication lines terminating at the (baseplate) (discharge pipe). Standard bearings will be grease lubricated (unless otherwise specified). The motor pedestal is to be of cast iron, two piece construction, fitted with a sealed thrust ball bearing located 6" above the baseplate. The ball bearing collar will be arranged

to allow external axial adjustment of the shaft and impeller. Grease seals shall be provided to retain grease and to prevent contamination of the vertically mounted ball bearing. A grease fitting will be provided to allow regreasing of the bearing. A packed stuffing box complete with a split gland shall be provided for gastight construction. The upper head shall be of sufficient height to elevate the motor shaft extension should the motor be removed for servicing. The pump shall be controlled by an enclosed (heavy duty) (watertight and explosion resisting) (explosion proof) type float operated switch 6" above the baseplate with plastic float and float rod. A flexible bellows will provide gastight construction. An automatic alternator shall be furnished on duplex pumps to allow the pumps to alternate on each successive cycle of operation. The pumps are to be driven by and flexible coupled to a standard "HP" . . . H.P. . . volt. . . phase. . . Hertz. . . R.P.M. . . vertical solid shaft (open drip-proof) (totally enclosed) (explosion proof) electric motor. A conduit box will be provided as well as a drip cover.

NOTE: Aurora Pump reserves the right to make revisions to its products and their specifications, and to this bulletin and related information without notice.

— Your Authorized Local Distributor —



MARKETING & SALES:
 800 AIRPORT ROAD • NORTH AURORA, ILLINOIS U.S.A. • 60542
 PHONE: (630) 859-7000 U.S.A./CANADA FAX: (630) 859-7040
 WORLDWIDE FAX: (630) 859-1226
WEB: www.aurorapump.com
EMAIL: aurora_info@pentairpump.com
AURORA MFG. PLANT:
 800 AIRPORT ROAD • NORTH AURORA, ILLINOIS U.S.A. • 60542
 SALES OFFICES IN ALL MAJOR CITIES AND COUNTRIES
 Refer to "Pumps" in yellow pages of your phone directory for your local Distributor.