



AURORA PUMP
A member of PENTAIR PUMP GROUP

INSTRUCTION MANUAL

REPAIR

MODEL 521A-522A

6

SERVICE

Your Aurora pump requires no maintenance other than periodic inspection, occasional cleaning and lubrication. The intent of inspection is to prevent breakdown, thus obtaining optimum service life. The pump bearing is grease lubricated and requires periodic lubrication as does the head bearing. Refer to lubrication section for specific instructions. The motor may also require lubrication, in which case, the motor manufacturer's recommendation should be followed.

LUBRICATION (BALL BEARINGS)

Regreasable ball bearings will require periodic lubrication and can be accomplished by using the zerk or lubrication fittings in the head assembly. Lubricate the bearing at regular intervals using a grease of high quality. Lithium, lithium soda or calcium base grease is recommended as lubricants for pumps operating in both wet and dry locations. Mixing of different brands of grease should be avoided due to possible chemical reactions between the brands which could damage the bearing. Accordingly, avoid grease of vegetable or animal base which can develop acids, as well as grease containing rosin, graphite, talc and other impurities. Under no circumstances should grease be reused.

Over lubrication of ball bearings should be avoided as it may result in overheating and possible bearing failure. Under normal application, adequate lubrication is assured if the amount of grease is maintained at 1/3 to 1/2 the capacity of the bearing and adjacent space surrounding it.

In dry locations ball bearings will need lubrication at least every 4,000 hours of running time or every 6 to 12 months, whichever is more frequent. In wet locations the ball bearings should be lubricated at least after every 2,000 hours of running time or every 4 to 6 months, whichever is more frequent. A unit is considered to be installed in a wet location if the head assembly and motor are exposed to dripping water, to the weather, or to heavy condensation such as is found in unheated and poorly ventilated underground locations.

At times it may be necessary to clean the bearings due to accumulated dirt or deteriorated lubricants. This can be accomplished by flushing the bearing with a light oil heated to 180 to 200° F. while rotating it on a spindle. Wipe the bearing housing with a clean rag soaked in a cleaning solvent, and flush all surfaces.

Dry bearing thoroughly before relubricating. Compressed air can be used to speed drying, but care should be taken not to let bearings rotate while being dried.

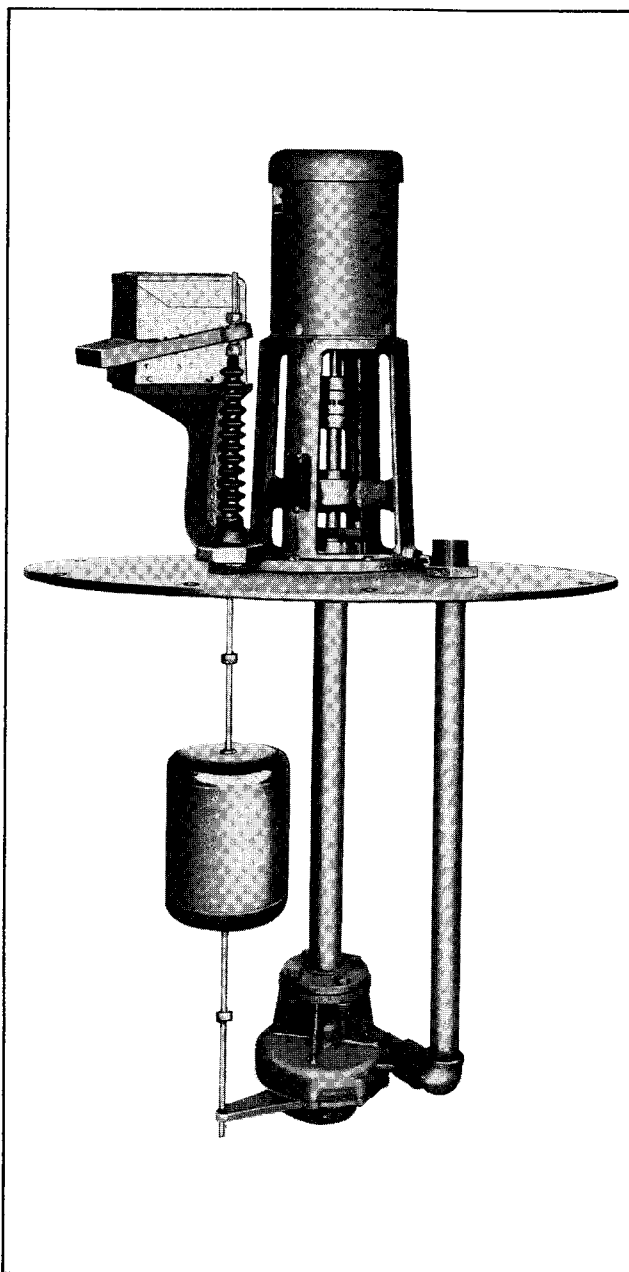

A. Complete unit assembly.

CAUTION

Use normal fire caution procedures when using any petroleum cleaner.

LUBRICATION (LINE SHAFT & OPTIONAL GREASE LUBRICATED PUMP BEARINGS)

Grease lubricated sleeve bearings will require frequent lubrication which can be accomplished by using the zerk fitting(s) located on the pump base. It is suggested that relubrication intervals be at least every 20 hours of running time.

REPAIRS

The pump may be disassembled using the illustrations and text provided. Although complete disassembly is covered, it will seldom be necessary to completely disassemble your Aurora pump.

The illustrations accompanying the disassembly instructions show the pump at various stages of disassembly. The illustrations are intended to aid in the correct identification of the parts mentioned in the text.

Inspect removed parts at disassembly to determine their reusability. Pump or line shaft bearings that are scored or noticeably out of round should not be reassembled. Cracked castings should never be reused and scored or worn pump shafts should be replaced.

All packings and gaskets should be replaced with new ones at reassembly simply as a matter of economy. They are much less expensive to replace routinely than to replace singly as the need arises. In general, it is economical to return to the manufacturer for repair only the motor and motor controller.

DISASSEMBLY

Disassemble only what is needed to make repairs or accomplish inspection. Proceed to disassemble the pump as follows: (Refer to figure 1.)

1. Disconnect wiring from motor control panel to motor and float switch. Take any other steps needed to prevent drive unit from being unintentionally energized during disassembly.
2. Remove the float switch. For instructions, refer to the repair notes on float switches.
3. Unscrew capscrews (54) to remove motor (52) from head (53). Lift motor free from lower half of coupling (48).
4. Coupling half (48) is removed by loosening set-screw (47). Similarly, setscrew (44) will free upper coupling half (45). Remove coupling keys (46 and 49) and insert (43).
5. Remove remaining pump and connected parts from basin to continue disassembly.

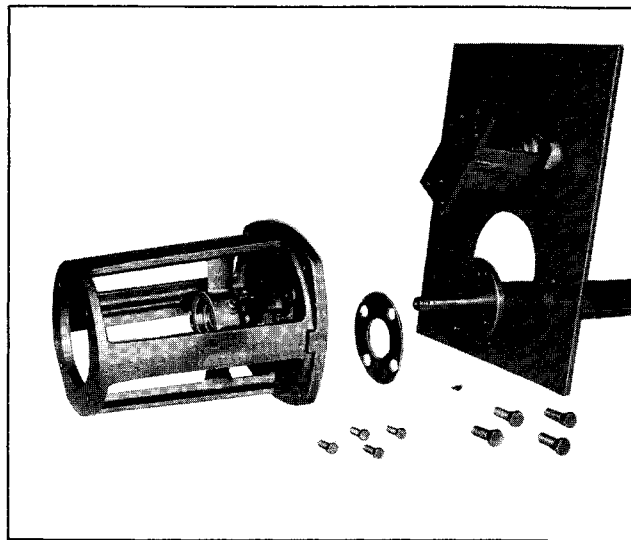

B. Upper head removed.

NOTE

However, if ventilation piping is used, remove it before lifting off plate.

6. Remove dust cap (57), collar setscrew (81) and slide bearing collar (56) from shaft. Bearing (58) is press fitted in head (53) and a puller is needed if removal is necessary.

7. Remove grease seal (59) if necessary.

NOTE

Grease seal (59) should not be removed except for replacement because its case is easily damaged. When removal is necessary, it can be tapped out of its seat in the lower head with coupling key (49) used as a driving tool.

8. Remove nuts (66), washers (65), clamps (67) and gland (68) from studs (69). Remove packing (70).

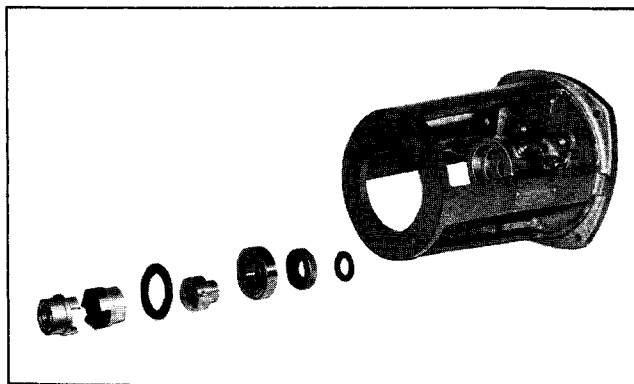

C. Couplings, cap, collar, bearing, grease seal and slinger removed.

NOTE

This stuffing box arrangement is optional. Standard stuffing box will be furnished with neoprene slinger (60) only.

9. Remove grease fitting (74). Disconnect any lubrication line used to lubricate line shaft bearings or piping for pressurized support column water supply.

10. Unscrew capscrews (42 and 80) to remove head (53) from support piping (40) and pump plate.

11. Remove upper locknut (77) from discharge piping (78). Then plate can be lifted off. Remove gasket (23). Remove screws (83) and nameplate (82) only if replacement is necessary.

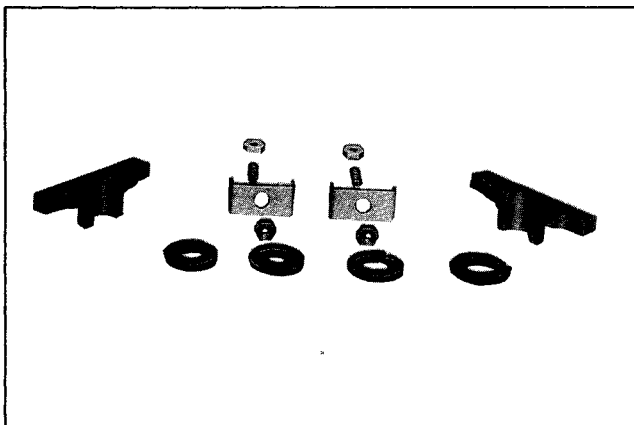

D. Packing box assembly removed (optional).

12. Successive lengths of piping and shafting are disassembled as follows:

- a. If a line shaft bearing is lubricated through an oil or grease line, detach the line and elbow from pipe nipple in upper support section and then remove nipple.
- b. Unscrew capscrews (39) and nuts (38) to lift top support pipe section and expose pump bearing (26). Slide line shaft bearing (26) off shaft. Remove gasket (23).

13. Discharge piping (78) and street elbow (75) can be removed from casing (8) by unthreading with a pipe wrench.

14. To remove remaining support piping (40), unscrew capscrews (21) from casing (8). Remove gasket (23).

15. Unthread capscrews (1) with washers (2) to remove strainer (3). Cover (22) and gasket (10) may be freed by removing capscrews (7).

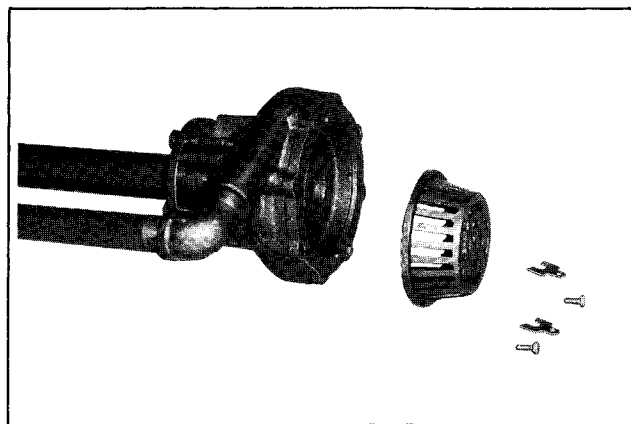

E. Strainer removed.

16. Slide shafting (61), impeller (15) and pump bearing (30) from casing (8).

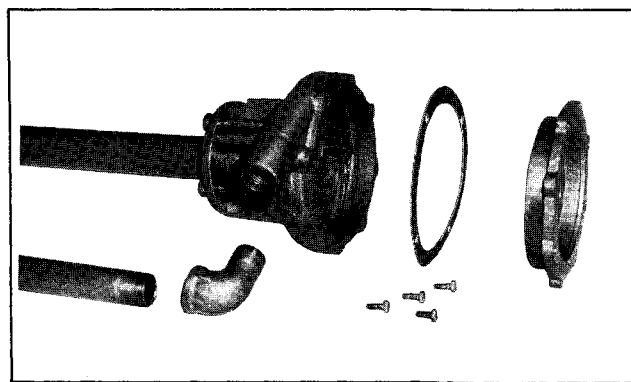

F. Cover, gasket and discharge pipe removed.

17. Impeller (15) is press fitted onto shaft (61). If removal is necessary a puller will be required. Loosen setscrew (13), remove impeller (15) and impeller key (16).

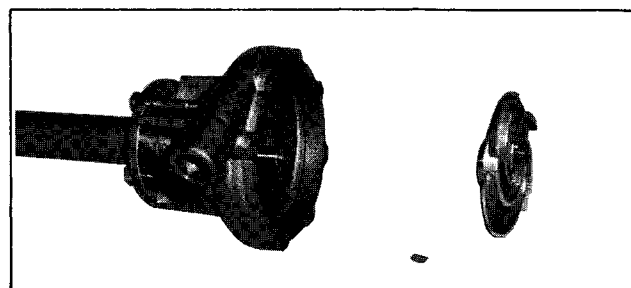

G. Impeller removed.

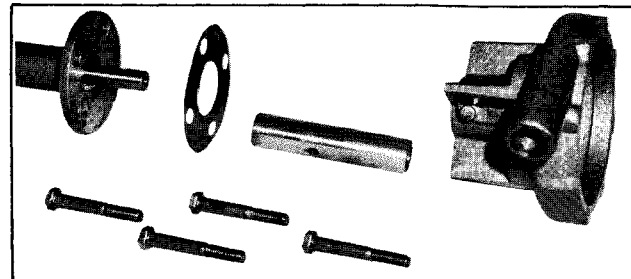

H. Casing and gasket removed.

MODEL 521A-522A

REASSEMBLY

Reassembly will generally be in reverse order of disassembly. If disassembly was not complete, use only those steps related to your particular repair program.

1. Slide pump bearing (30) onto pump end of shaft. Place impeller key (16) in shaft (61) and replace impeller (15). Secure with setscrew (13).

2. Slide shaft and impeller assembly into casing (8). If pump bearing (30) is to be lubricated through a grease line, align tapped opening in the bushing with vent opening in the casing and install a 1/4 inch pipe nipple to maintain the alignment.

3. Replace gasket (10) on cover (22) and bolt to casing (8) with capscrews (7). Replace strainer (3) with capscrews (1) and washers (2).

4. Slide gasket (23) over motor end of shaft (61) and position on casing (8). Slide pump end of support piping (40) onto shaft (61) and bolt to casing (8) with capscrews (21).

5. Thread street elbow (75) into casing (8). Discharge piping (78) may now be threaded into elbow (75).

NOTE

If pump bearing is to be lubricated through a grease line, assemble the required elbow and tubing on previously installed nipple. If support column is to be pressurized with a flow of fresh water, connect the required 3/4 inch pipe nipple, elbow and pipe to support piping, and be certain that other vent openings are plugged.

6. Successive lengths of piping and shafting are assembled as follows: (pumps designed for pump settings* deeper than 5 feet, 2 inches are provided with multiple part support piping and with line shaft bearings at each support piping joint).

- a. Slide a line shaft bearing (26) down pump shaft, with tapped opening toward upper end until it seats against the flange of the previously assembled section of support piping (40).
- b. If the line shaft bearing is to be lubricated through a grease line, turn bearing as required to align tapped opening with lubricant piping. Position support pipe gasket (23) against support pipe flange and lower the next section of support piping into place. Turn it to align vent opening with tapped opening in line shaft bearing, and secure it by installing capscrew (39) and nuts (38). Install any 1/8 inch pipe nipple in tapped opening of line bearing, if required, and connect it to previously assembled lubrication piping.

* "Pump setting" is the distance from bottom of strainer (3) to bottom of head (53). This measurement is normally 3 inches less than "pit depth," the distance from bottom of basin to top face of basin.

7. Place locknut (77) on discharge pipe (78) and thread down approximately 1 inch.

8. Seat grease seal (59) with sealing edge upward in its seat in elevated section of head (53).

9. Press ball bearing (58) onto bearing collar (56). Press bearing and collar into elevated portion of head (53). Place dust cap (57) over bearing collar in head.

10. Lower pump plate over support piping (40) and discharge piping (78). Position gasket (23) on support pipe flange and slide head (53) into place.

NOTE

Install float control at this time, if liquid end is not accessible when pump is lowered into basin.

11. Lift pump plate into position against head (53) and install capscrews (80 and 42). Place locknut (77) on discharge pipe (78) and tighten locknuts above and below the plate to secure discharge piping in place. Secure bearing collar (56) to pump shaft (61) with collar setscrew (81). Screw grease fitting (74) in elevated head (53). Pump support plate and pump assembly may now be lowered into place on basin cover and can be bolted down.

12. Install slinger (60) for standard fitted pumps. For optionally equipped pumps, install packing (70) around shaft in head. Place studs (69) in head (53). Assemble packing gland halves (68) on studs (65) and nuts (66). Do not tighten nuts more than finger tight unless pump support piping is to be pressurized with fresh water.

NOTE

Connect pressurization or lubrication piping at this time by using opening provided in pump support plate. For pressurization piping, a 3/4 inch line to water supply is connected to tapped opening in head. For lubrication piping, line is connected to grease fitting.

13. Install coupling half (48) and key (49) on upper end of pump shaft, and tighten coupling setscrew (47) temporarily to prevent its slipping down shaft.

MODEL 521A-522A

14. Position coupling insert (43) in lower half of coupling and secure upper coupling half (45) with its key (46) on motor output shaft. Align bottom end of key with key slot in the end surface of motor shaft and secure by tightening setscrew (44).

15. Lower motor (52) carefully into position on head (53) while engaging coupling halves with coupling insert. Bolt motor to head (53) with capscrews (54).

16. Loosen setscrew (47) in lower coupling half (48) and slide coupling half and key (49) upward until they engage coupling insert (43) with proper clearance as shown in Section 2, Item 4 of this instruction manual.

17. If nameplate (82) was removed, replace at this time with screws (83).

NOTE

Install float switch at this time. For instructions, refer to the repair notes on float switches.

18. Connect wiring from motor control panel to motor and float switch, following exactly the instructions provided by their respective manufacturers. Also connect solenoid valve at this time if used, using diagrams provided. All wiring must comply with applicable electrical code requirements for type of duty pump is to perform.

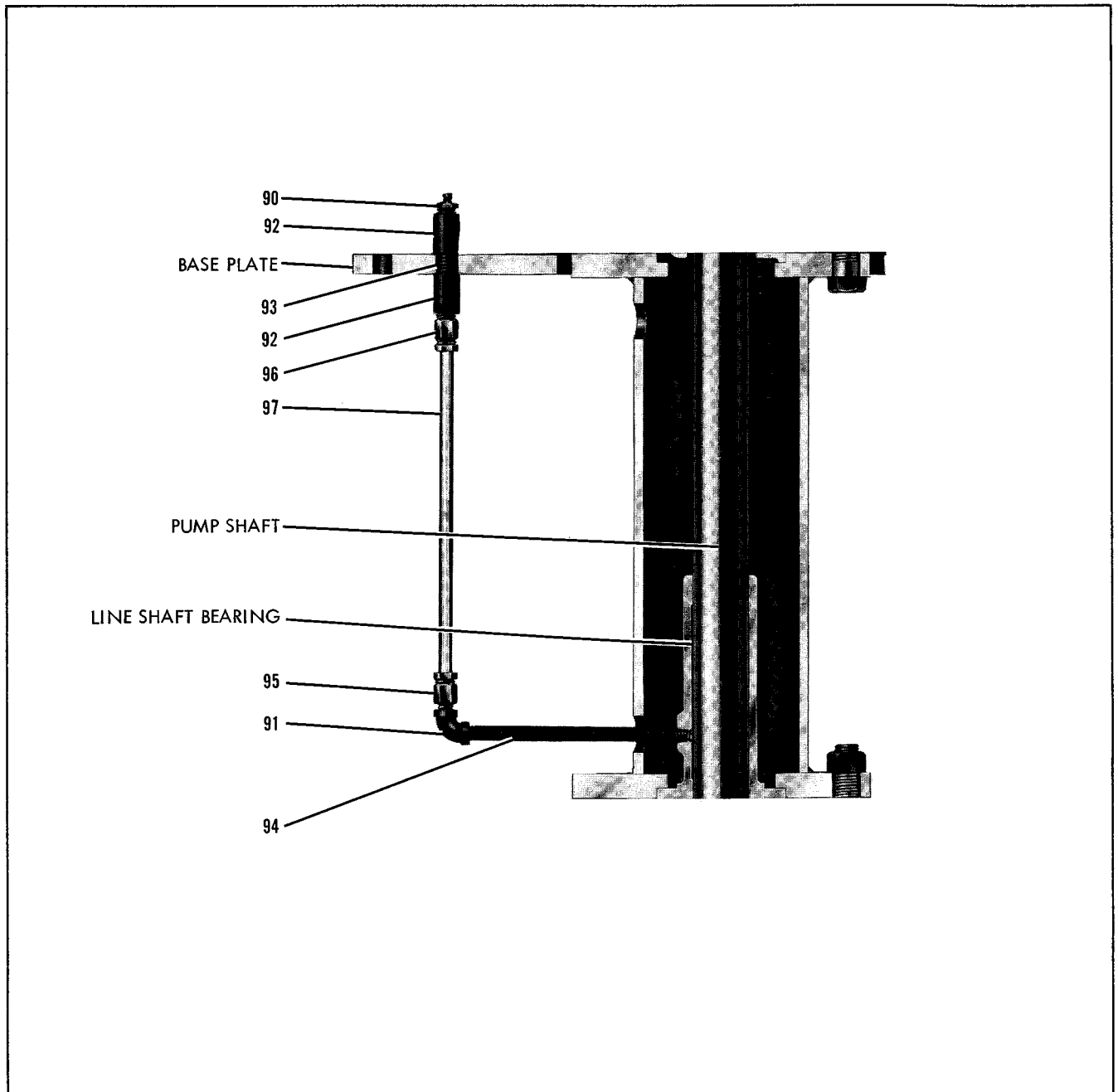

MODEL 521A-522A

MODELS 521A & 522A LIST OF PARTS

1. Retainer	45. Coupling Half	74. Fitting
3. Strainer	46. Key	75. Street Elbow
7. Capscrew	47. Setscrew	77. Locknut
8. Casing	48. Coupling Half	78. Discharge Pipe
10. Gasket	49. Key	80. Capscrew
13. Impeller Setscrew	52. Motor	81. Collar Setscrew
15. Impeller	53. Head	82. Nameplate
16. Impeller Key	54. Capscrew	83. Screw
21. Capscrew	56. Bearing Collar	90. Grease Fitting
22. Cover	57. Dust Cap	91. Elbow
22A. Rod Guide	58. Bearing	92. Coupling
23. Gasket	59. Seal	93. Close Nipple
26. Line Shaft Bearing	60. Slinger	94. Nipple
30. Pump Bearing	61. Shaft	95. Comp. Fitting
38. Nut	65. Washer	96. Comp. Fitting
39. Capscrew	66. Nut	97. Nylon Tube
40. Support Pipe	67. Clamp	
42. Capscrew	68. Gland	
43. Insert	69. Stud	
44. Setscrew	70. Packing	

NOTE

WHEN ORDERING SPARE PARTS ALWAYS INCLUDE THE PUMP TYPE, SIZE, SERIAL NUMBER, AND THE PIECE NUMBER FROM THE EXPLODED VIEW IN THIS MANUAL.

ORDER ALL PARTS FROM YOUR LOCAL AUTHORIZED DISTRIBUTOR, FACTORY BRANCH SALES OFFICE OR THE FACTORY AT NORTH AURORA, ILLINOIS.

MODEL 521A-522A

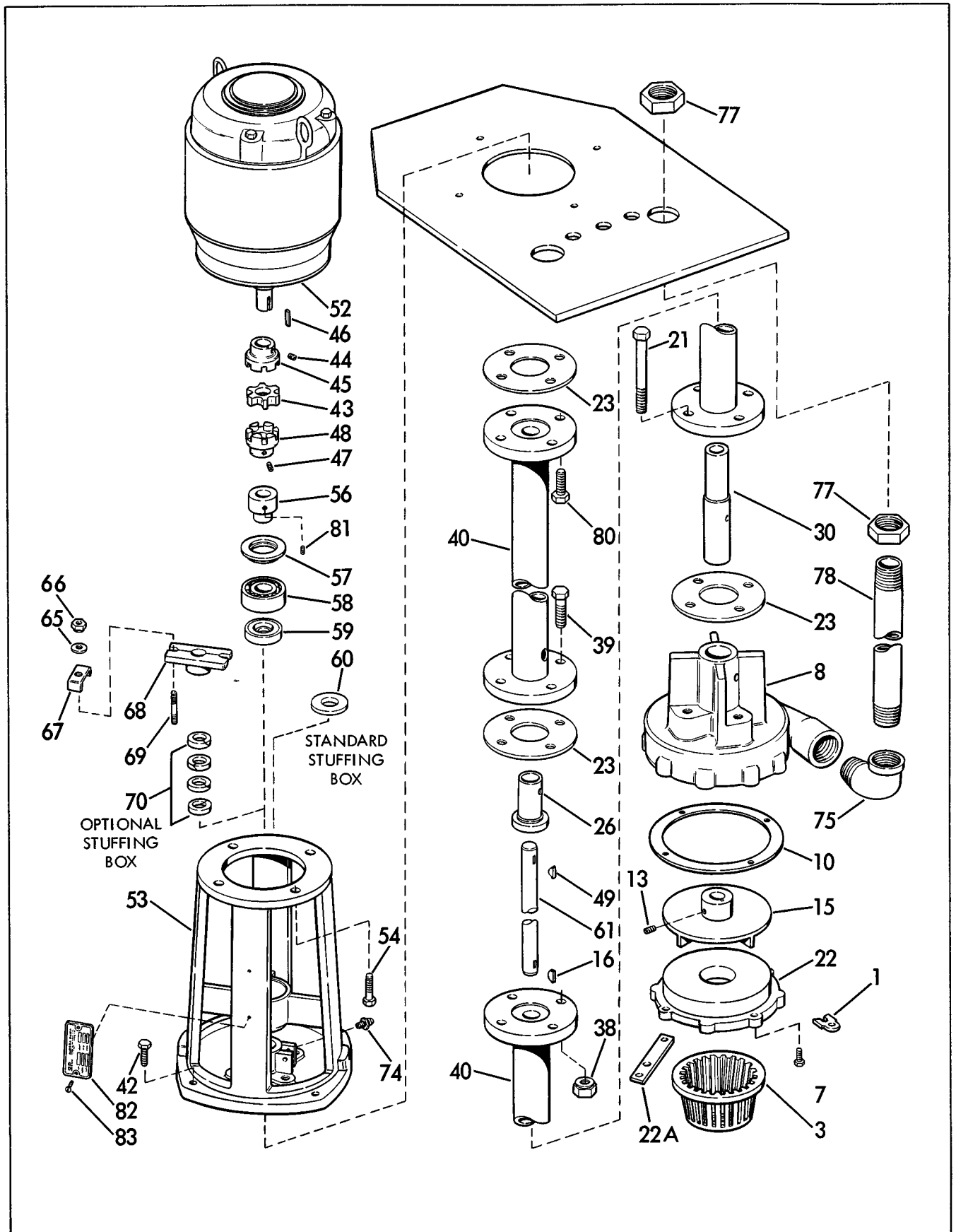

Figure 1. Model 521A-522A Exploded View