

430B Series Two-Stage Split Case Pumps

- Capacities To 400 GPM
- Heads To 1,000 Feet
- Temperatures To 300° F
- Power Series No. 2 and 3A

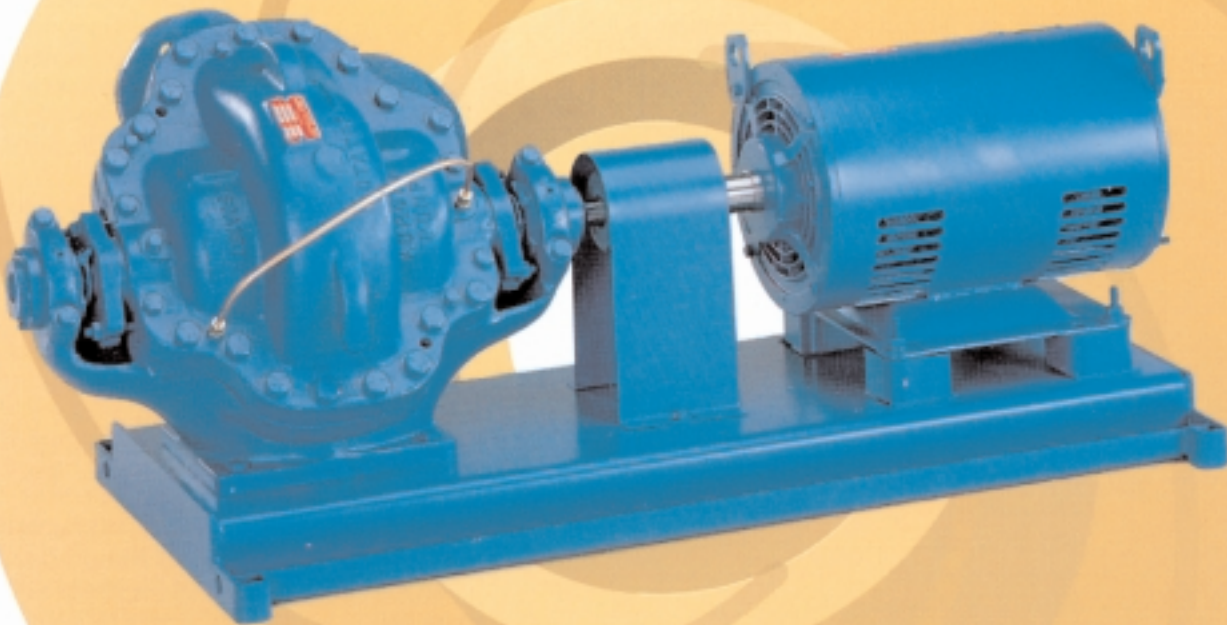

ap AURORA®

PENTAIR PUMP GROUP

430B Series Pumps

Pump Features

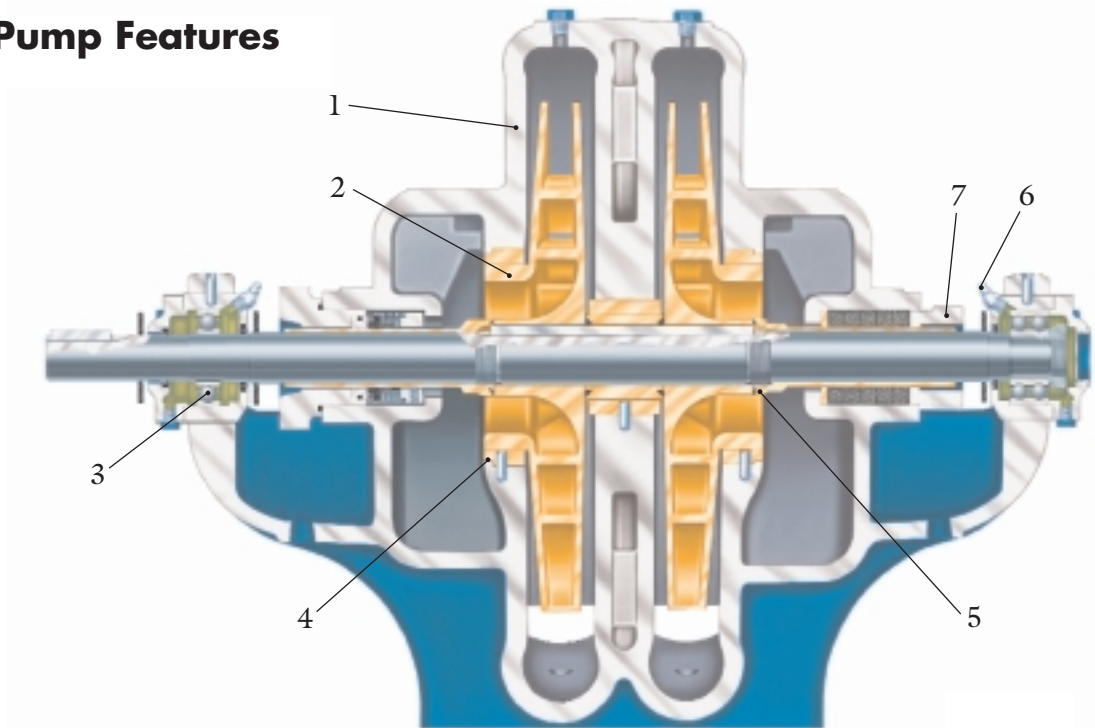

- 1** **DIAGONAL SPLIT CASING** is suited for many applications. Important among these uses is **BOILER FEED SERVICE**, as well as hot or volatile liquid applications requiring low NPSH characteristics. The 45° diagonally split case feature allows both suction and discharge to be in the bottom half of the casing but above the centerline of the pump. This feature makes the casing self-venting. Because they are self-venting they **WILL NOT VAPOR LOCK**. Large suction areas give ideal NPSH characteristics. All of the advantages of the horizontally split case pumps are retained in that the entire rotating element can be removed without disturbing the piping.
- 2** **DYNAMICALLY BALANCED IMPELLERS** are keyed to shaft and secured by adjustable shaft sleeves. Design provides highest efficiency and performance.
- 3** **BEARINGS** selected for 50,000 hour minimum life at maximum load. Average bearing life is 5 x minimum. Double row thrust ball bearing is standard on Power Series 2 models. Duplex back to back ball bearings on Power Series 3A models. Short bearing span holds shaft deflection to .002" at face of stuffing box at maximum load. Outboard thrust bearing locked to shaft with lock nut. Integral bearing arms eliminate bearing misalignment and simplify servicing.
- 4** **CASE WEARING RINGS** and throttle bushings prevent wear on the pump casing and are easily and inexpensively replaced.
- 5** **BRONZE SHAFT SLEEVE** prevents shaft wear, is slip fit over the shaft, and keylocked.
- 6** **GREASE LUBRICATION** purges old grease from bearings. Oil lubrication is optional.
- 7** **INTERCHANGEABLE STUFFING BOX** for mechanical seals or packing. Packing is optional. Standard mechanical seals have carbon against Ni-Resist face. Long life is assured with 303 stainless steel metal parts and "Buna-N" Elastomer.

Specifications and Dimensions

High discharge pressures often require the use of multi-stage pumping units, which impose additional demands on the pump design. Various pressures and forces generated within a multi-stage unit must balance, making shaft and bearing design more critical than in single stage units. Aurora Pump has been designing and building multi-stage pumping units for over 50 years. The 430B series reflects the latest in modern design for this important product.

Standard

Bronze fitted pump construction
Bronze shaft sleeves, "O" ring sealed

- Dynamically balanced impellers
- Bronze case wearing rings
- Stainless steel impeller key
- Regreasable ball bearings
- Single row ball bearing (inboard)
- Double row ball bearing (Power Series 2 - outboard)
- Duplex back to back ball bearings (Power Series 3A - outboard)
- Single mechanical seals
- Flanges per ANSI B16.1: class 125 suction, class 250 discharge
- Max. case working pressure
- Power Series 2-250 psi
- Power Series 3A-450 psi
- Carbon steel shaft
- Lifting lugs
- Hydrostatic test
- Cast integral bearing arms
- Water slingers (neoprene)
- Grease seals
- Mechanical seal flush line
- Right hand rotation

Optional

- All iron, or iron impeller pump construction
- Hardened 440C stainless steel shaft sleeves (packing only)
- 316 s. stl. shaft sleeves (mech. seal)
- Oil lubricated bearings
- Mechanical seals: single unbalanced, high-temp.
- Cartridge type mechanical seals
- Stainless steel or monel shaft
- External bypass to stuffing boxes
- Steel drip rim or fabricated bases

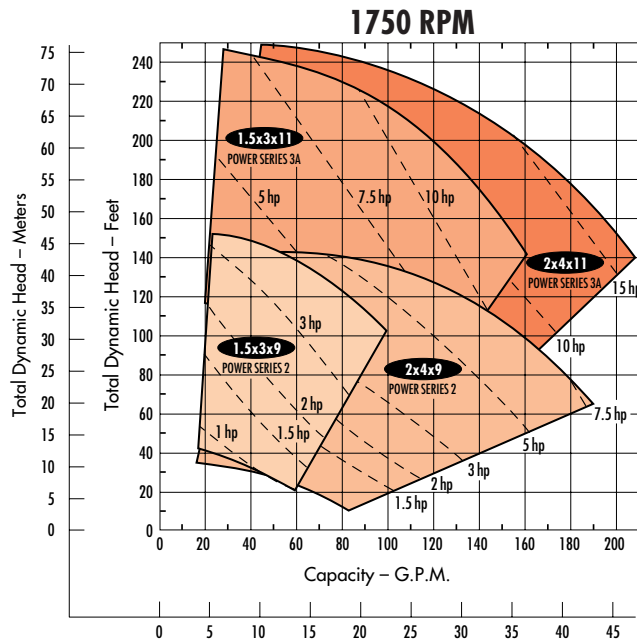
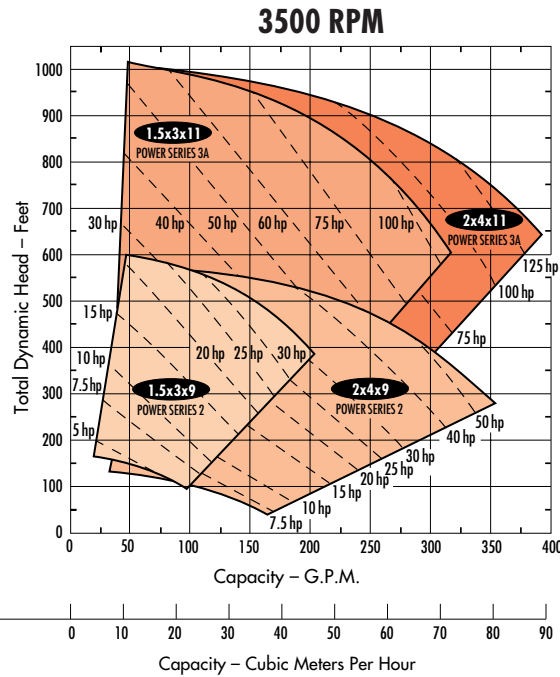

- Left hand rotation
- Certified performance test
- Packing with lantern ring
- 250# ANSI B16.1 suction & discharge flanges
- Water cooled bearing cartridge caps
- Metallic/Plastic hi-temp packing
- Stuffing box bushings

Note: For BHP and NPSH requirements see individual performance curves.

Engineering Specifications

MODEL 431B BASE MOUNTED – Furnish and install as shown on the plans.....Right hand (Left hand) Aurora Model 431B type 45° Diagonal Split-Case, Opposed Suction, Two-Stage centrifugal pump, Size.....x..... of bronze fitted (all iron) construction. The pump shall be capable of delivering at design conditions a capacity ofG.P.M. when operating against a Total Dynamic Head of.....feet, with a temperature of.....°F, specific gravity.....Pump shall have minimum guaranteed efficiency at design capacity of.....%. Pump must also be capable of delivering a maximum ofG.P.M. when operating against a head of..... feet, and at this condition shall have a minimum efficiency of.....%. Minimum shut off head acceptable will be.....feet. Pump shall operate at a maximum speed of.....R.P.M. A unit operating at a lesser rotative speed will be considered, but in no event will a pump operating at more than the maximum speed specified be acceptable. The pump casing shall be with rear piping design and will be constructed of C.I. having a minimum tensile strength of 30,000 psi and shall be of sufficient thickness to withstand stresses and strains at full operating pressures. Casings shall be subject to a hydrostatic pressure test at 150% of the specified duty point. Bearing housing supports, suction and discharge flanges shall be integrally cast with the lower half of the casing. Removal of the upper half of the casing must allow the rotating

element to be removed without disconnecting the suction and discharge flanges. The upper casing is to be dowel aligned to the lower casing. Both halves of the casing must be self-venting to prevent vapor lock. Drain openings must be provided in the bearing arms for removal of lubricating liquid. Impellers shall be of the enclosed, opposed suction type and shall be of vacuum cast bronze (.....). Impellers shall be dynamically balanced and securely fastened to the shaft by key and screw locked shaft sleeves. The vanes shall be designed to reduce noise. The pump shaft shall be made of high grade SAE 1045 Steel or equal, accurately machined to give a true running rotating element. The minimum dia. acceptable will be.....". The shaft shall be protected from wear by bronze (.....) sleeves which are key locked and threaded so that the sleeves tighten with rotation of the shaft. EPR-o-rings must be provided between the impeller hub and the shaft sleeves to prevent pumped liquid from corroding the shaft. Pump shall be equipped with easily renewable bronze (.....) casing rings so designed that hydraulic pressure will seat them against a shoulder in the pump case around the full periphery of the wearing ring. The wear rings will be locked in place by doweling to prevent rotation. The rotating element shall be mounted in heavy-duty grease lubricated ball bearings and equipped with bronze water slingers for packed pumps on side next to pump glands. (Neoprene slingers on mechanical seal pumps). Bearing housings shall

be so designed to flush lubricant through and provide continuous cleaning of bearing surfaces and maximum protection against overheating. The bearing housings are to be of C.I. and shall be furnished with a set of regreaseable (Optional oil lubricated on Model 431B) bearings for both radial and thrust loads. The bearings shall have an average life of 250,000 hours and shall be mounted in machined, moisture and dust proof housings. The housings are to have register fits and then be bolted to the pump casing to insure permanent alignment. Stuffing boxes (packing) (m. seal) shall be placed on both sides of the pump centerline to seal the pump shaft. All standard mechanical seal pumps will have flushline from 2nd to 1st stage stuffing boxes. All packed pumps having a suction lift shall have a 1st stage lantern ring connected to the pressure side of the pump by a bypass line to the parting flange of the pump. The stuffing boxes shall be equipped with heavy, cast, glands. Pump and motor shall be mounted on a common heavy base plate of (steel drip rim) (formed steel) (structural steel). Pump and motor must be checked for alignment after the pump base has been installed and grouted in place, in accordance with the standards of the Hydraulic Institute. There shall be no strain transmitted to the pumps. The diagonal split case pumps shall be flexible coupled to a standard horizontal NEMA.....HP.....phase..... Hertz.....volts.....RPM (drip-proof) (totally enclosed) (explosion-proof) motor.

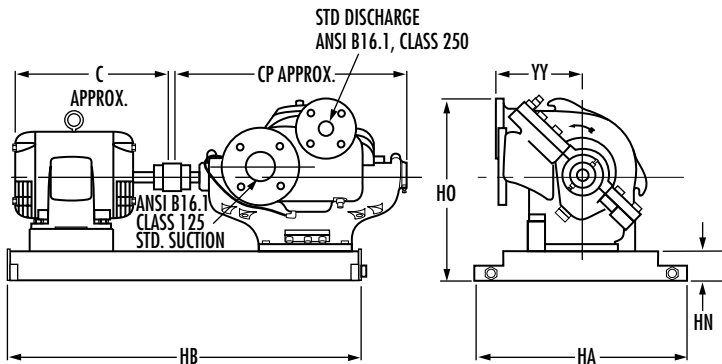

BASE	PUMP SIZE					PUMP					MOTOR FRAME	BASE															
	3	5	6	8	9	11	143 T	145 T	182 T	184 T		213 T	215 T	254 T	256 T	284 TS	284 T	286 TS	286 T	324 TS	324 T	326 TS	364 TS	365 TS	404 TS	405 TS	
WGT	49	59	68	96	109	164	HP 3500	1 1/2	2-3	5	7 1/2	10	15	20	25	30	-	40	-	50	-	60	75	100	125	150	
HA	15	17 1/2	17 1/2	20 1/2	20 1/2	26 1/2	HP 1750	1	1 1/2	3	5	7 1/2	10	15	20	25											
HB	33 1/2	36 1/2	42 1/2	42 1/2	48 1/2	46 1/2	MTR. WGT.	40	45	72	80	130	145	220	240	330	370	370	370	475	475	525	710	775	975	1030	
HN	3	3	3	3	3	4	C	12	13	13	14	16	18	21	23	22	24	24	25	25	26	26	27	28	30	31	
DIS	3	3	3	3	3	3																					
SUCT	3	3	3	3	3	3																					
BORE	9	9	9	9	9	9																					
WGT	300	300	300	300	300	300																					
YY	9	9	9	9	9	9																					
CP	26 1/2	26 1/2	26 1/2	26 1/2	26 1/2	26 1/2																					
HO	19 1/2	19 1/2	19 1/2	19 1/2	19 1/2	19 1/2																					

Limitations

- | | |
|--------------------------------------------------------------------------------------|------------|
| 3500 R.P.M., 150 H.P. | Max. Temp. |
| 1. Standard mechanical seals | 230°F |
| 2. High temp. mechanical seals with flushing at seal faces and water cooled bearings | 300°F |
| 3. Packing with hardened stainless steel shaft sleeves | 225°F |

Max. case working pressure (all or any part can be suction pressure)*
 Power Series 2-250 psi
 Power Series 3A-450 psi
 675 PSI Hydrostatic test pressure (Max)
 *Packing...Suction lift requires lantern ring. Above 100 PSI suction pressure requires hardened stainless steel shaft sleeves.
 *Seals...Above 100 PSI suction pressure requires balanced seal.

Description	Material of Construction
Casing halves	Cast iron ASTM A48
Packing rings	Alternating rings of babbit foil and aramid fiber
Case wearing rings	Bronze ASTM B62
Sleeves	Bronze High Lead Tin
Impellers	Bronze ASTM B584
Key	Stainless steel AISI 416
Shaft	Steel AISI C1045

1. Dimensions and weights are approximate. 2. Complete dimensions are available. 3. Not for construction purposes unless certified for approval. 4. Frame sizes shown are for open drip proof motors only. 5. Add pump, base and motor weight for unit weight total. 6. Conduit box is shown in approximate position. Dimensions are not specified as they vary with each motor manufacturer. 7. Aurora Pump reserves the right to make revisions to its products and their specifications, and to this bulletin and related information without notice. 8. Individual performance curve must be used for final selection. For selection not shown on range charts, refer to factory.

NOTE: Aurora Pump reserves the right to make revisions to its products and their specifications, and to this bulletin and related information without notice.

— Your Authorized Local Distributor —



MARKETING & SALES:
 800 AIRPORT ROAD • NORTH AURORA, ILLINOIS U.S.A. • 60542
 PHONE: (630) 859-7000 U.S.A./CANADA FAX: (630) 859-7060
 WORLDWIDE FAX: (630) 859-1226

WEB: www.aurorapump.com
EMAIL: aurora_info@pentairpump.com

AURORA MFG. PLANT:
 800 AIRPORT ROAD • NORTH AURORA, ILLINOIS U.S.A. • 60542

SALES OFFICES IN ALL MAJOR CITIES AND COUNTRIES
 Refer to "Pumps" in yellow pages of your phone directory for your local Distributor.