

380 Series Single Stage Vertical Inline Pump

- Capacities to 4500 G.P.M. (1,020 M³/HR)
- Heads to 370 Feet (78 Meters)
- Temperatures to 250°F (120°C)

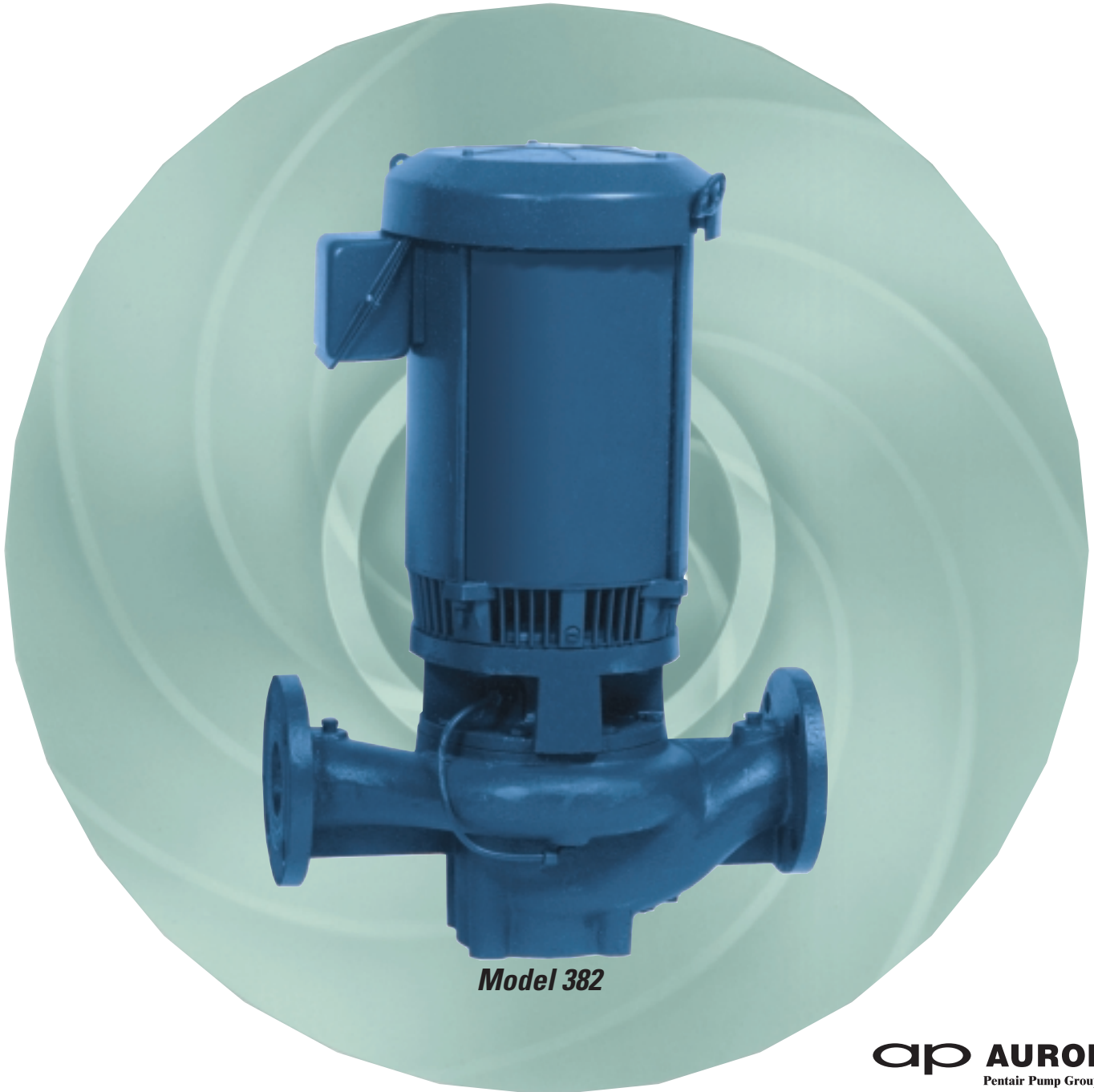

Model 382

Aurora 380 Series Pumps

Vertical Inline Close Coupled Pumps are specifically designed for mounting, in any position, directly in a pipe line. The suction and discharge nozzles are located on the same centerline 180° apart. Vertical pumps significantly reduce the space required, two pumps fit in the space of one. They are easy to maintain; simply remove the capscrews and the motor and bracket assembly is easily removed from the casing without disturbing the piping.

The impeller is direct coupled to the motor shaft for easy maintenance to minimize impeller run out and reduce noise. Most pump parts except for the casing, are 100% interchangeable with Aurora Pump's high quality, high production 340 and 360 series pumps for speedy spare parts service. The inline casing has provisions for mounting an optional support base should the pump sit on the floor. Mechanical seals are provided as standard to prevent leakage around the shaft. A relief line is provided from the seal faces to the pump discharge for flushing and venting purposes.

Suction Branch Design on Model 382A pumps prerotates suction liquid in the direction of pump impeller rotation. This concept minimizes pumping noise that is otherwise associated with more common short radius suction inlet designs. Each pump has been engineered and assurance tested to arrive at the proper velocities and entrance angles to insure quiet operation.

Aurora 380 Series pumps are available in 31 sizes, offering a size and model precisely fitted to a wide range of head and capacity requirements.

Look through this bulletin for additional details and specifications.

Feature Selector

STANDARD

- Bronze Fitted Construction
- Bronze Shaft Sleeve
- Carbon Steel Shaft
- Dynamically Balanced Cast Impeller
- Casing Wearing Rings
- 303 Stainless Mechanical Seal With Buna-N, Ni-Resist and Carbon Parts
- Factory Hydro Test

OPTIONAL

- All Iron Construction
- 316 Stainless Steel Shaft Sleeve
- Impeller Wearing Ring (s)
- Suction and Discharge Companion Flanges
- Pump Base
- Certified Performance Test data Consisting of Head Capacity and Power Readings Taken Over the Full Operating Range of the Pump.

Pump Features

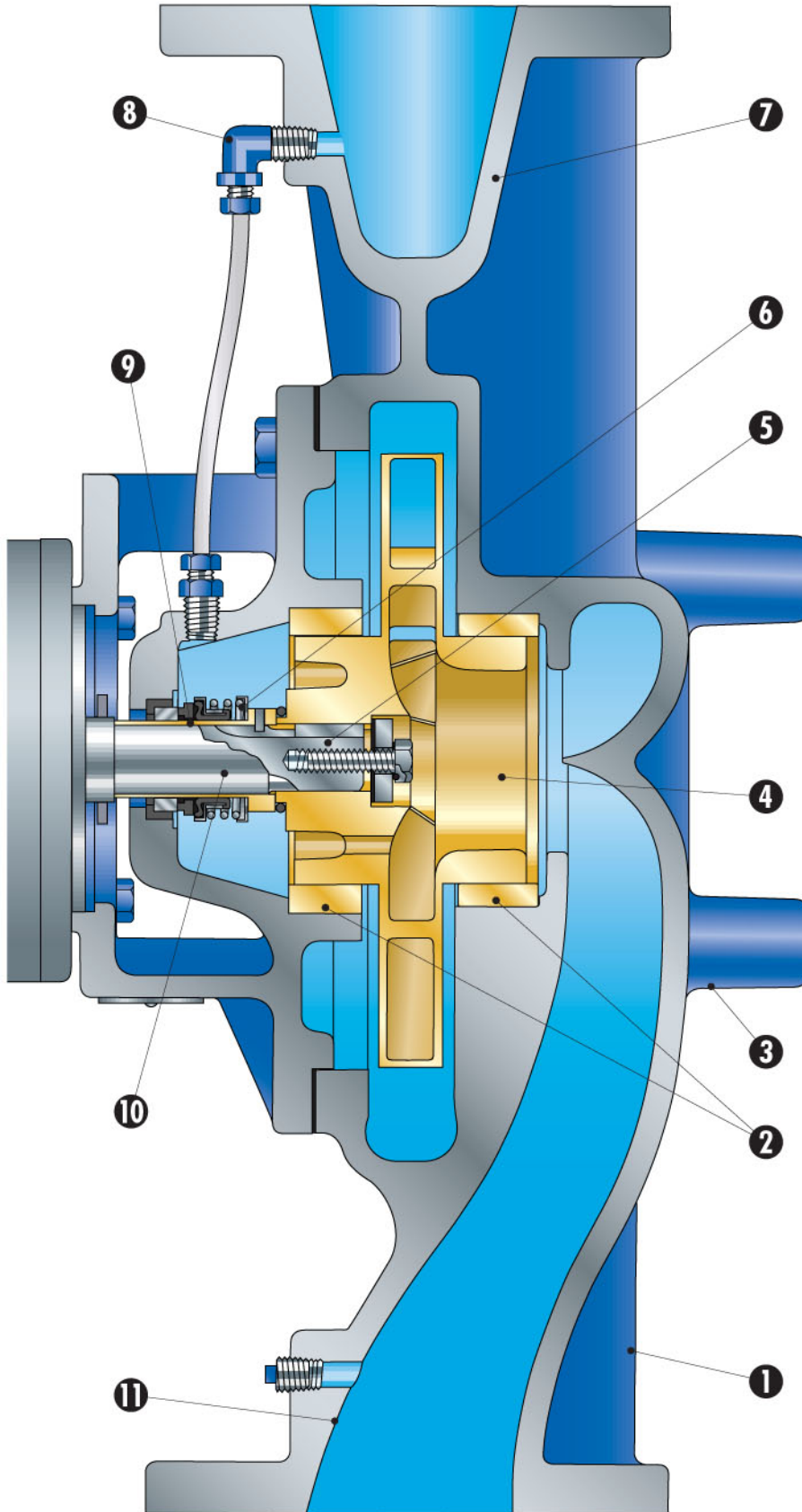

FEATURES

1. BACK PULL-OUT CASING with inline suction and discharge.
2. CASE WEARING RING prevents wear on casing and is inexpensively replaced. Impeller wear rings are optional.
3. SUPPORT FEET are cast integrally with the casing on Model 382A pumps. The pump thus can alternately sit on the floor or bolt to an optional base if a foundation is preferred.
4. PRECISION CAST, DYNAMICALLY BALANCED, ENCLOSED IMPELLER is keyed to the shaft extension and secured by a capscrew and washer. Gaskets are used to prevent leakage to shaft end.
5. CARBON STEEL SHAFT is designed for minimum deflection.
6. MECHANICAL SEAL has carbon against Ni-Resist face for optimum hot water performance. Long life is assured with 303 Stainless steel metal parts and "Buna-N" flexible elastomers.
7. FACTORY HYDRO TEST guarantees casting and seal integrity.
8. RELIEF LINE assures adequate venting of the seal chamber and lubrication of seal faces.
9. BRONZE SHAFT SLEEVE prevents shaft wear and extends the entire length of the seal box. The shaft sleeve is slip fit over the shaft and then is keylocked. Shaft sleeve and impeller screw are sealed by o-ring gaskets to eliminate corrosion of the shaft by the pumped liquid. This standard feature eliminates the requirements for higher costing, special stainless steel shaft.
10. STANDARD JM MOTOR (10-60) HP provides low noise level pump operation. Special TCZ Motor for above 60HP.
11. VOLUTE TYPE SUCTION inlet pre-rotates suction liquid.

380 Dimensions

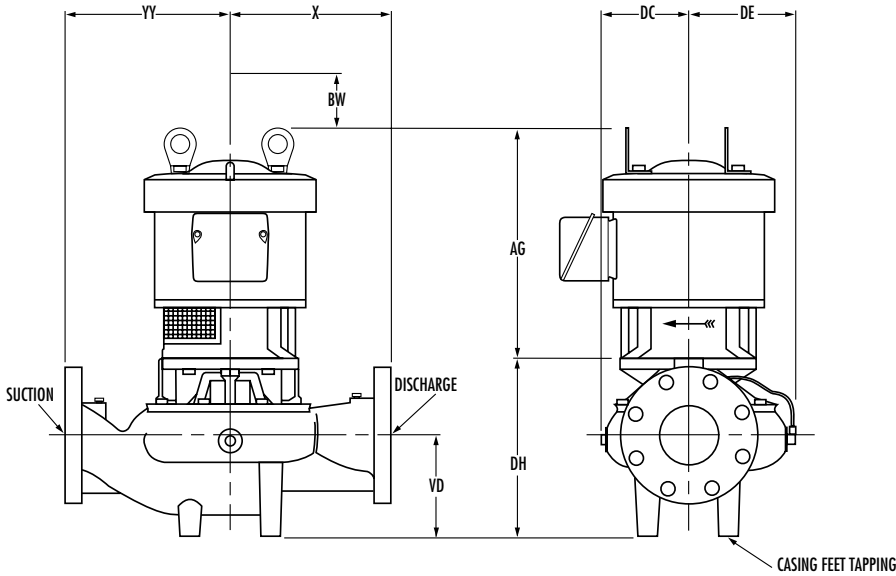

FRAME	AG APPROX.	
	O.D.P.	T.E.F.C. EXP. PR.
143JM	10	12
145JM	11	13
182JM	12	14
184JM	15	17
213JM	17	19
215JM	17	19
254JM	21	23
256JM	21	23
284JM	22	24
286JM	22	24
324JM	24	26
326JM	24	26
364TCZ	25.62	26.88
365TCZ	25.62	26.88
404TCZ	30	30-1/2
405TCZ	30	30-1/2
444TCZ	31-3/4	32-1/2
445TCZ	31-3/4	35-1/2

PUMP SIZE			X	BW (MIN)	DC	DE	DH			YY	VD	CASING FEET TAPPING
DISCHARGE	SUCTON	CASE BORE					143JM THRU 215JM	254JM THRU 326JM	365TCZ THRU 445TCZ			
1-1/2	1-1/2	9B	9-1/2 (241)	4 (102)	5-3/4 (146)	6-1/8 (156)	10 (254)	N/A	-	9-1/2 (241)	5-1/4 (133)	NOTE 8
2	2	7	8 (203)	3-1/2 (89)	4-1/2 (114)	5-1/8 (130)	9-13/16 (249)	N/A	-	8 (203)	5 (127)	NOTE 9
2	2	9A, B	9-1/2 (241)	4-1/2 (114)	5-7/8 (149)	6-3/8 (162)	10 (254)	N/A	-	9-1/2 (241)	5-1/4 (133)	NOTE 8
2	2	9C	9-1/2 (241)	4-1/2 (114)	5-7/8 (149)	6-3/8 (162)	9-9/16 (243)	10-9/16 (268)	-	9-1/2 (241)	5-1/4 (133)	NOTE 9
2	2	12	12 (305)	5 (127)	7-5/8 (194)	8 (203)	10-1/8 (257)	11-1/8 (283)	-	12 (305)	5-1/4 (133)	NOTE 8
2-1/2	2-1/2	7	9 (229)	3-1/2 (89)	4-3/4 (121)	5-1/2 (140)	10-9/16 (268)	11-9/16 (294)	-	9 (229)	5-5/8 (143)	NOTE 10
2-1/2	2-1/2	9	10 (254)	4 (102)	5-7/8 (149)	6-5/8 (168)	10-1/2 (267)	11-1/2 (292)	-	10 (254)	5-5/8 (143)	NOTE 10
3	3	7A, B	9-1/2 (241)	5 (127)	5-3/16 (132)	6-1/8 (156)	11-5/8 (295)	12-5/8 (321)	-	9-1/2 (241)	6-1/4 (159)	NOTE 10
3	3	9A	11 (279)	4-1/2 (114)	6 (152)	6-3/4 (171)	11-3/8 (289)	12-3/8 (314)	-	11 (279)	6-1/4 (159)	NOTE 10
3	3	9B	11 (279)	5 (127)	6-1/4 (159)	7-1/8 (181)	11-1/2 (292)	12-1/2 (318)	-	11 (279)	6-1/2 (165)	NOTE 8
3	4	9	11 (279)	4-1/2 (114)	5-3/4 (146)	6-1/2 (165)	10-7/8 (276)	11-7/8 (302)	-	11 (279)	5-7/8 (149)	NOTE 10
3	3	12	14 (356)	5 (127)	7-11/16 (195)	8-1/4 (210)	11-1/2 (292)	12-1/2 (318)	-	12 (305)	6-1/2 (165)	NOTE 8
4	4	7A, B	11 (279)	6 (152)	5-9/16 (141)	7-5/16 (186)	12-3/4 (324)	13-3/4 (349)	-	11 (279)	7-1/4 (184)	NOTE 10
4	4	9A, B	11 (279)	6 (152)	6-3/16 (157)	7-5/16 (186)	12-3/8 (314)	13-3/8 (340)	-	11 (279)	7-1/4 (184)	NOTE 8
4	5	9	11 (279)	4-1/2 (114)	6 (152)	7-1/8 (181)	12-1/8 (308)	13-1/8 (333)	-	11 (279)	7 (178)	NOTE 10
4	4	11	13 (330)	5 (127)	7-1/8 (181)	8-1/4 (210)	12-13/16 (325)	13-13/16 (351)	-	13 (330)	7-5/8 (194)	NOTE 11
4	4	12	13 (330)	4-1/2 (114)	7-7/8 (200)	8-3/4 (222)	12-1/4 (311)	13-1/4 (337)	-	13 (330)	7 (178)	NOTE 11
5	5	9	14 (356)	4-3/4 (121)	7-1/8 (181)	8-1/2 (216)	13 (330)	14 (356)	-	14 (356)	7-5/8 (194)	NOTE 11
5	5	11	14 (356)	4-1/2 (114)	7-3/8 (187)	8-7/8 (225)	14 (356)	15 (381)	-	14 (356)	8-5/8 (219)	NOTE 11
5	5	12	15 (381)	4-3/4 (121)	8-1/4 (210)	9-1/2 (241)	13-1/2 (343)	14-1/2 (368)	-	15 (381)	8 (203)	NOTE 11
6	6	9	15 (381)	5-1/4 (133)	7 (178)	9 (229)	13-1/2 (343)	14-1/2 (368)	-	15 (381)	8 (203)	NOTE 11
6	6	11	15 (381)	6 (152)	8 (203)	10 (254)	15 (381)	16 (406)	-	15 (381)	9-1/4 (235)	NOTE 11
6	6	12	15 (381)	5-1/2 (140)	8-3/8 (213)	10 (254)	14-1/2 (368)	15-1/2 (387)	-	15 (381)	8-3/4 (222)	NOTE 11
8	8	11	18 (457)	6 (152)	8-3/4 (222)	10-7/8 (276)	15-5/8 (397)	16-5/8 (422)	-	18 (457)	9-5/8 (244)	NOTE 11
8	8	12	18 (457)	6 (152)	8-3/4 (222)	10-7/8 (276)	15-5/8 (397)	16-5/8 (422)	-	18 (457)	9-5/8 (244)	NOTE 11
8	8	15	22-1/2 (572)	13 (330)	10.34 (263)	12.91 (328)	-	-	20.88 (530)	22-1/2 (572)	12.13 (308)	NOTE 12
10	10	15	25 (635)	13 (330)	11 (279)	14.38 (365)	-	-	22-1/4 (565)	25 (635)	12.56 (319)	NOTE 12

- NOTES:
- All dimensions in inches and (mm).
 - Dimensions may vary $\pm 1/4"$ (6).
 - Not for construction purposes unless certified.
 - N/A = not applicable.
 - Conduit box is shown in approximate location. Dimensions are not specified as they vary with each motor manufacturer.
 - Suction and discharge flanges - 125# ANSI Standard flat face.
 - Dimension BW is clearance required for servicing.
 - Normally not tapped. Optionally available [4] 5/8" UNC taps matching 4"-125# flange drilling (7.5" bolt circle).
 - Tapped [4] 5/8" UNC taps matching 2"-125# flange (4.75" bolt circle).
 - Tapped [4] 5/8" UNC taps matching 3"-125# flange (6.0" bolt circle).
 - Tapped [4] 5/8" UNC taps matching 4"-125# flange (7.5" bolt circle).
 - Tapped [4] 3/4" UNC taps matching 6"-125# flange (9.5" bolt circle).

380 Range Charts

3500 RPM

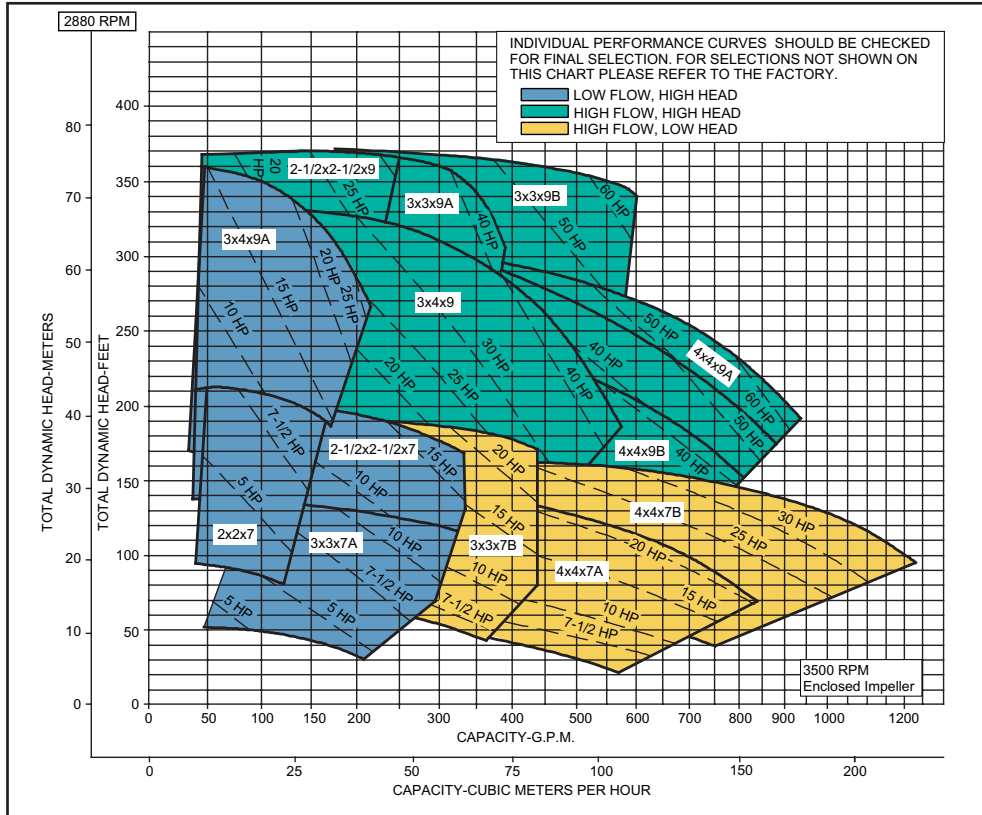

1750 RPM

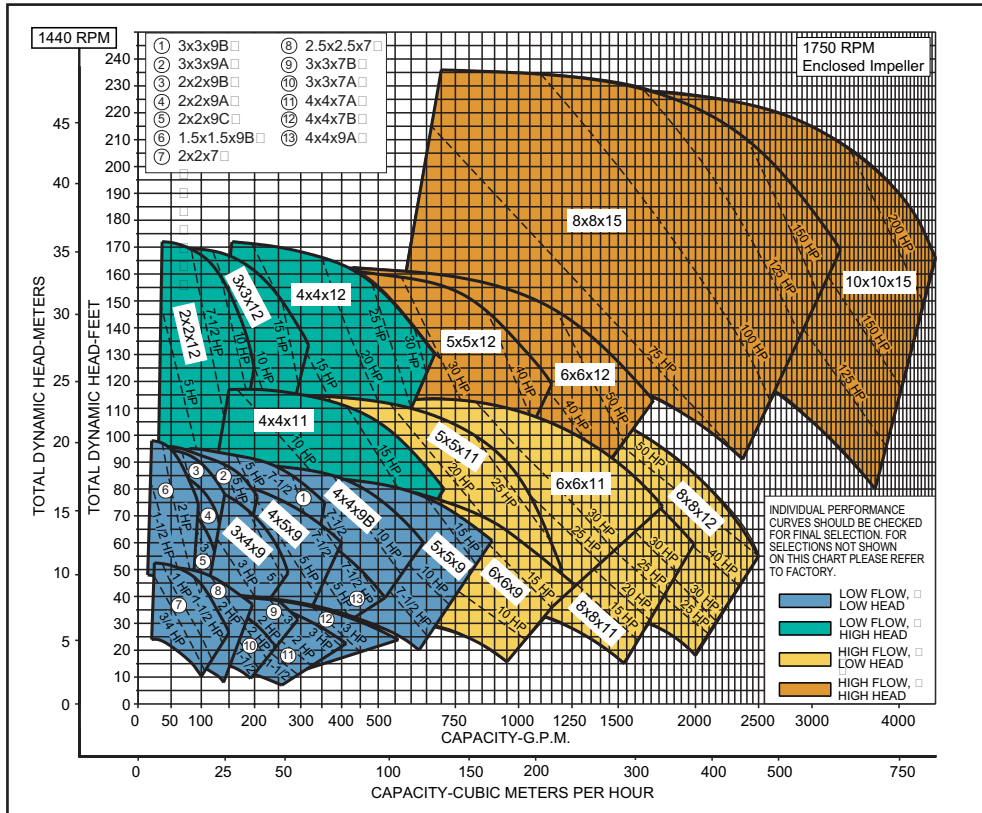

Engineering Specifications

The contractor shall furnish (and install as shown on the plans) Aurora Model 382A vertical close coupled inline back pull-out centrifugal pumps sizeX.....X..... of (bronze fitted) (all bronze) (all iron) construction.

The suction and discharge flanges shall be located on a common CL 180° apart for mounting in-line. Each pump shall have a capacity ofGPM atFt. total head, with a temperature of°F,specific gravity.

Each pump is to be furnished with a mechanical seal with all metal parts to be 303 stainless steel with Buna-N elastomers, Ni-Resist seat and carbon washer. A bypass line must be provided between the seal faces and the discharge flange to assure adequate venting of the seal chamber and to provide lubrication. Impellers are to be dynamically balanced and keylocked to the shaft. Model 382A pumps to include a volute type casing suction branch to minimize pumping noise.

The unit must be equipped with (bronze) (stainless steel) shaft sleeve, keylocked, that extends the length of the seal box. Pump shaft extension shall be o-ring sealed from the pumped liquid. Pump casing shall have a case wearing ring (impeller wearing rings). Each pump is to be close coupled to a standard NEMA-JMHPPhaseHertzVoltRPM (drip proof) (total enclosure) (explosion proof) motor up to 60 HP and special TCZ frame motor for HP above 60.

Materials of Construction and Limitations

PUMP PART	BRONZE FITTED
Casing	Cast Iron ASTM A48
Impeller	Bronze ASTM B584
Shaft	Carbon Steel Per Motor Mfg.
Case Wearing Rings	Bronze ASTM B62
Sleeve	Bronze ASTM B62
Bracket	Cast Iron ASTM A48
Mechanical Seal (STD)	
Washer	Carbon
Seat	Ni-Resist
Elastomer	Buna-N
Metal Parts	303 SS
Spring	303 SS

MAXIMUM LIMITATION BASED ON STANDARD MATERIALS AND PUMPING CLEAR WATER	
Speed	3500 RPM
Horsepower	1150 RPM 30
	1750 RPM 50
	3500 RPM 60
	TCZ FRAME MOTORS RTF
Temperature °F	Standard 225/Optional 250
Hydrostatic Test Pressure PSI	265
Case Working Pressure PSI (All or Any Part Can Be Suction Free)	175



NOTE: Aurora Pump reserves the right to make revisions to its products and their specifications, and to this bulletin and related information, without notice.

— Your Authorized Local Distributor —



MARKETING & SALES:
800 AIRPORT ROAD • NORTH AURORA, ILLINOIS U.S.A. • 60542
PHONE: (630) 859-7000 U.S.A./CANADA FAX: (630) 859-7060
WORLDWIDE FAX: (630) 859-1226

AURORA MFG. PLANT:
800 AIRPORT ROAD • NORTH AURORA, ILLINOIS U.S.A. • 60542

SALES OFFICES IN ALL MAJOR CITIES AND COUNTRIES
Refer to "Pumps" in yellow pages of your phone directory for your local Distributor

