

**ap**

AURORA PUMP A member of PENTAIR PUMP GROUP

**AURORA PUMP**

BULLETIN 370B/REV. C

**370 SERIES  
TWO STAGE  
END SUCTION  
PUMPS**

CAPACITIES TO 310 G.P.M.  
HEADS TO 790 FEET  
TEMPERATURES TO 300°F.

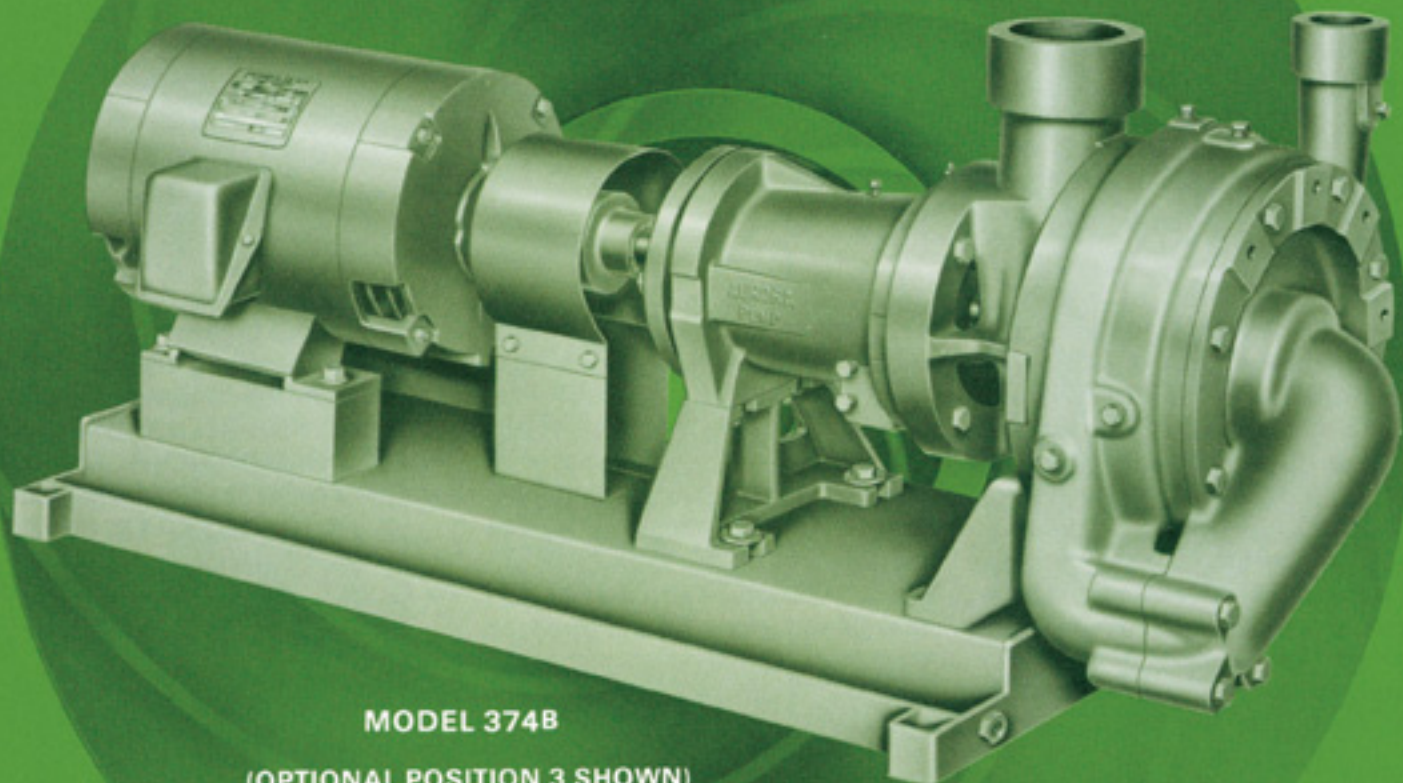

**MODEL 374B**

(OPTIONAL POSITION 3 SHOWN)



# INTRODUCTION

## AURORA 370 SERIES PUMPS

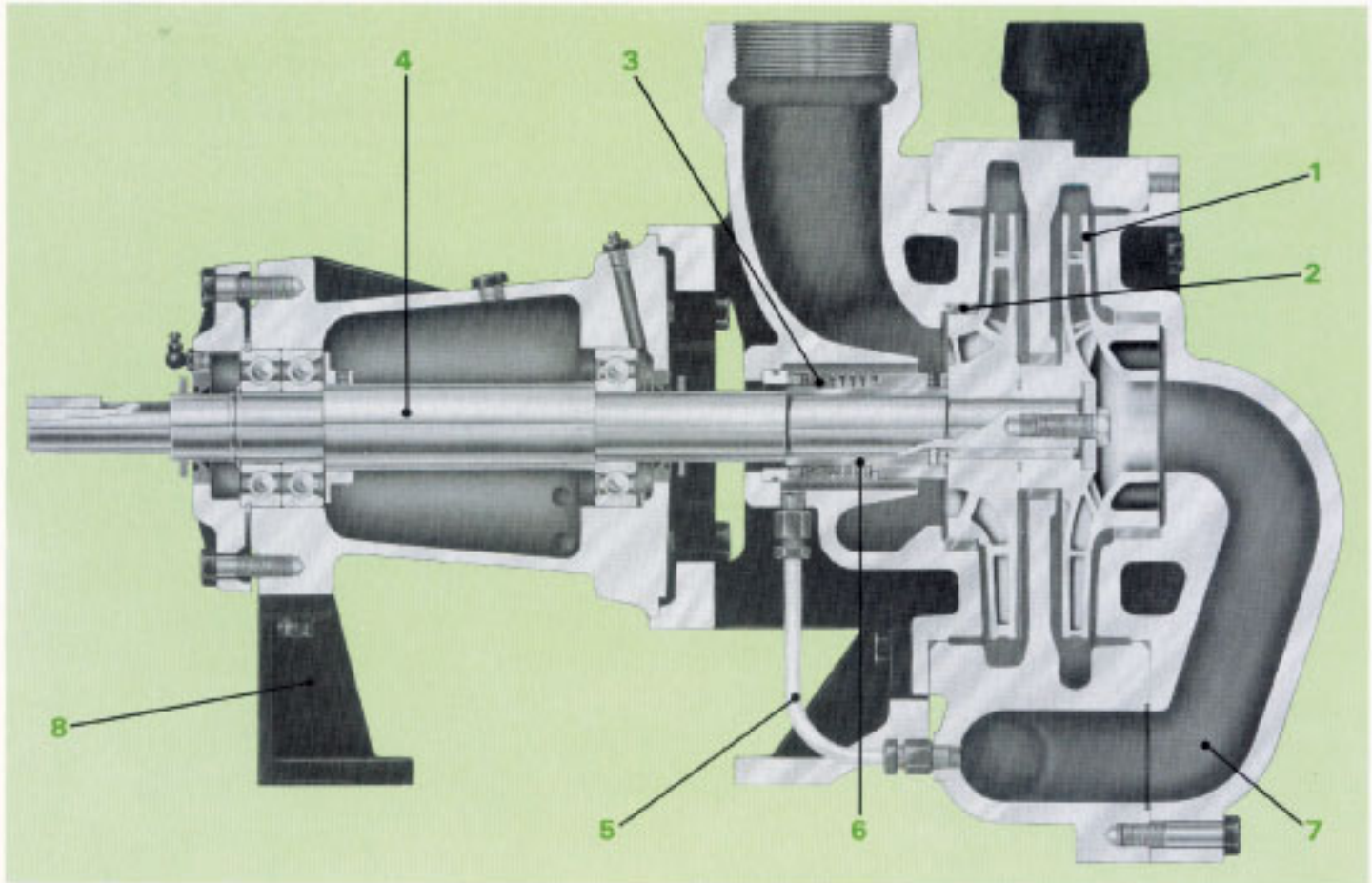

Compact system designs, application trends requiring increased pressures and temperatures and the much higher costs of engineering and construction have brought about a demand for a practical multi-stage frame mounted end suction pump. Various pressures and forces generated within a multi-stage unit must balance making

shaft and bearing design more critical than in single stage units. Split case pump designs readily solve the mechanical problems of multi-staging, but are costly. Aurora Pump, a leader in the pump industry, has combined over 75 years of knowledge in multi-stage split case and end suction design and manufacturing techniques to

produce a unique combination of technical features in the 370 Series. Significantly, this new Aurora pump design offers:

- LOW NPSH REQUIREMENTS
- RELIABLE OPERATION
- COMPACT DESIGN FOR EASY INSTALLATION AND MAINTENANCE
- QUIET, SMOOTH-RUNNING DESIGN FOR LONGER LIFE

### QUICK REFERENCE 370 SERIES FEATURE SELECTOR

#### STANDARD

Iron fitted construction  
Bronze shaft sleeves  
Dynamically balanced cast iron shell core enclosed impellers  
Bronze case wearing rings  
Regreasable bearings  
Discharge position No. 1  
Hydrostatic test  
Carbon steel shaft  
303 Stainless high temp. mech. seal  
"O" ring sealed shaft sleeve  
Coupling guard

#### OPTIONAL

All iron construction  
316 Stainless steel shaft sleeves  
Stainless steel shaft or sleeve  
Cast iron case wearing rings  
Oil lubricated ball bearings  
Alternate piping positions  
Steel drip-rim bases  
316 Stainless, special high temperature mechanical seal with Cranelast, Tungsten Carbide and Carbon parts



# PUMP FEATURES AND ENGINEERING DETAILS

**1 DYNAMICALLY BALANCED IMPELLERS** keyed to the shaft and secured by a capscrew and washer. Quality controlled manufacturing process assures consistently high performance. Enclosed design provides highest efficiency, low NPSH and minimum wear for long service life. After developing pressure in the first stage impeller the liquid is directed to a second stage impeller where the process is repeated, doubling the discharge head. By offsetting the discharges by 180°, the radial loads on the bearing are balanced and shaft deflection is minimized.

**2 CASE WEARING RINGS** prevent wear on casing and are easily and inexpensively replaced.

**3 HIGH TEMPERATURE MECHANICAL SEAL** is standard and located on the first stage to eliminate the need for costly high pressure seal and premature failure.

**4 CARBON STEEL SHAFT** is designed for minimum deflection, not to exceed .002" at the sealing faces at maximum load. Bearings selected for 2 years minimum life at maximum load. Average bearing life is 10 years. Grease lubrication is standard.

**5 RELIEF LINE** assures adequate venting of the seal chamber and lube of the seal faces.

**6 BRONZE SHAFT SLEEVE** prevents shaft wear and extends the entire length of the seal box. The sleeve is slip fit over the shaft and is keylocked. Shaft sleeve and impeller screw are sealed by "O" ring gaskets to eliminate corrosion of the shaft by the pumped liquid. This eliminates the requirements for high cost, stainless steel shafts.

**7 HYDROSTATIC TEST** guarantees casting and seal integrity.

**8 REAR SUPPORT FOOT** provides power frame support and simplifies coupling alignment.

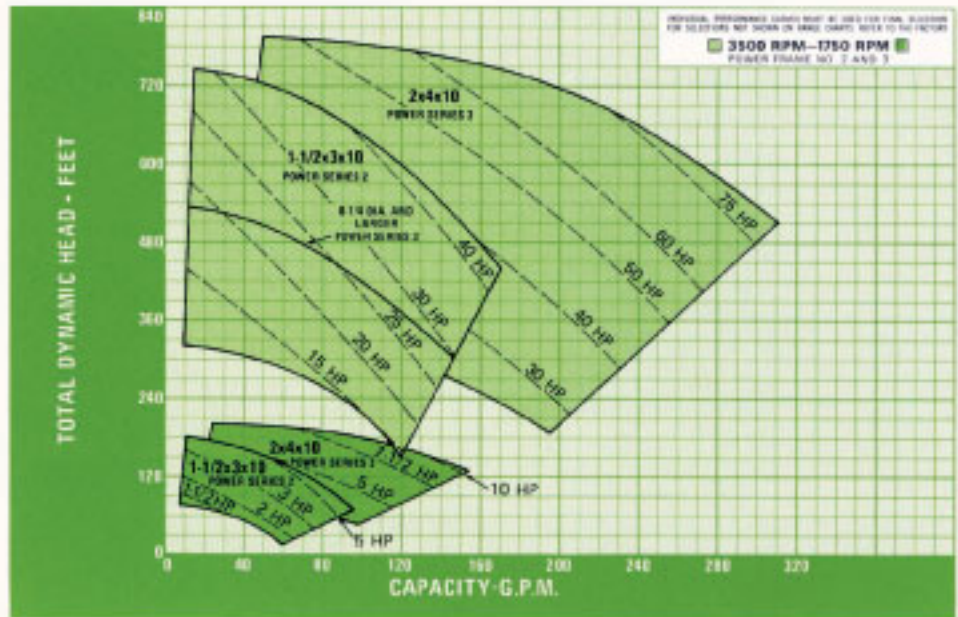

## LIMITATIONS

MAXIMUM LIMITATIONS BASED ON STANDARD MATERIALS AND PUMPING CLEAR WATER		
SPEED — RPM	MODEL 374	3900
H.P.	1 1/2 x 3 x 10	60
	2 x 4 x 10	100
HYDROSTATIC TEST PRESSURE P.S.I.		600
CASE WORKING PRESSURE P.S.I.	-20° to 150° F.	400
	200° F.	370
	225° F.	355
	250° F.	340
	275° F.	325
300° F.	310	
SUCTION PRESSURE P.S.I.		100
TEMP. °F	SEALING METHOD	FRAME MOUNTED
	STD. HIGH TEMP. MECHANICAL SEAL	225
	SPECIAL HIGH TEMP. MECHANICAL SEAL	300

## OUTBOARD TANDEM THRUST BEARING

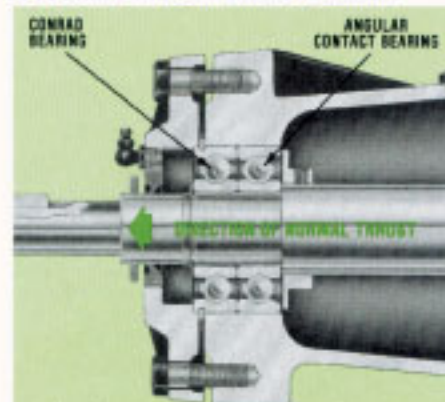

Angular contact bearing carries maximum thrust load in direction of normal thrust. Conrad bearing locks bearing assembly and carries reverse thrust load of reduced magnitude.

## DESIGN DETAILS

AREA	DESCRIPTION	POWER SERIES	
		2	3
PUMP SHAFT	ROTATION— FROM DRIVER END	CW	CW
	DIAMETER AT IMPELLER	1 1/4	1 1/2
	DIAMETER AT SHAFT SLEEVE	1 1/8	1 1/2
	DIAMETER BETWEEN BEARINGS	1 1/16	2 3/8
	DIAMETER AT COUPLING END	1 1/8	1 3/8
	COUPLING KEY — SQUARE	3/4	3/8
	MAX. DEFLECTION AT SEAL FACE	.002	.002
BALL BEARING	OUTSIDE DIA. OF SLEEVE	1 1/4	1 1/4
	BEARING (INB. RADIAL)	308	310
	BEARING (MATCHED SET) CONRAD	308	310
	ANGULAR CONTACT	7308	7310
	BEARING CENTERS	7 1/16	7 1/16
	MIN. B <sub>10</sub> BEARING LIFE UNDER MAXIMUM LOAD	2 YRS.	2 YRS.

## MATERIALS OF CONSTRUCTION

PUMP PART	IRON FITTED	ALL IRON
BRACKET	CAST IRON ASTM A48	CAST IRON ASTM A48
CASING	CAST IRON ASTM A48	CAST IRON ASTM A48
IMPELLERS	CAST IRON ASTM A48	CAST IRON ASTM A48
COVER	CAST IRON ASTM A48	CAST IRON ASTM A48
MECHANICAL SEAL	300 STAINLESS STEEL METAL PARTS. "Buna-N" ELASTOMER PARTS. NI-RESIST SEAT AND CARBON WASHER.	
POWER FRAME	CAST IRON ASTM A48	CAST IRON ASTM A48
SHAFT	STEEL AISI C1045	STEEL AISI C1045
SLEEVES	BRONZE ASTM B62	STAINLESS STEEL AISI 316
WEARING RINGS	BRONZE ASTM B62	CAST IRON ASTM A48



# ENGINEERING SPECIFICATIONS AND DIMENSIONS

The contractor shall furnish (and install as shown on the plans) Aurora Model (374 horizontal flexible coupled) centrifugal pump sizes 1½ x 3 x 10 or 2 x 4 x 10 (iron fitted) (all iron) construction. Each pump shall have a capacity of . . . . . G.P.M. at . . . . . ft. total head, with a temperature of . . . . . °F., . . . . . N.P.S.H. required and . . . . . specific gravity. Each pump is to be furnished with a (standard) (high temperature) mechanical seal with all metal parts to be (303) (316) stainless steel with ("Buna-N") (Cranelast) elastomers, (Ni-Resist) (Tungsten Carbide) seat, and carbon washer. The unit must be equipped with (bronze) (stainless steel) key-locked shaft sleeve that extends the length of the seal box. The pump shaft extension shall be "O" ring sealed from the pumped liquid. Pump shall have case wearing rings.

Impellers are to be precision shell core cast, dynamically balanced, and keylocked to the shaft.

Pump and motor are to be mounted on a common (formed steel drip rim) (steel) baseplate. The shaft is to be carbon steel, installed in a cast iron power frame. Pumps shall have a shaft design for .002" deflection at the seal face with the pump running under maximum load condition. (Grease) (Oil) lubricated ball bearings, having a 2 year minimum life (AFBMA B<sub>10</sub>) under the maximum condition of load and protected by separate oil seals and slingers, shall be used. The pump shall be flexible coupled to a standard horizontal NEMA . . . . . HP, . . . . . phase, . . . . . Hertz, . . . . . volts, . . . . . R.P.M., (drip-proof) (totally enclosed) (explosion-proof) motor. Alignment shall be checked in accordance with the Standards of the Hydraulic Institute after installation and there shall be no strain transmitted to pumps.

PUMP SIZE	PUMP WEIGHT
1½ x 3 x 10	215 LBS
2 x 4 x 10	325 LBS

**NOTE:** Aurora Pump reserves the right to make revisions to its products and their specifications, and to this bulletin and related information without notice.

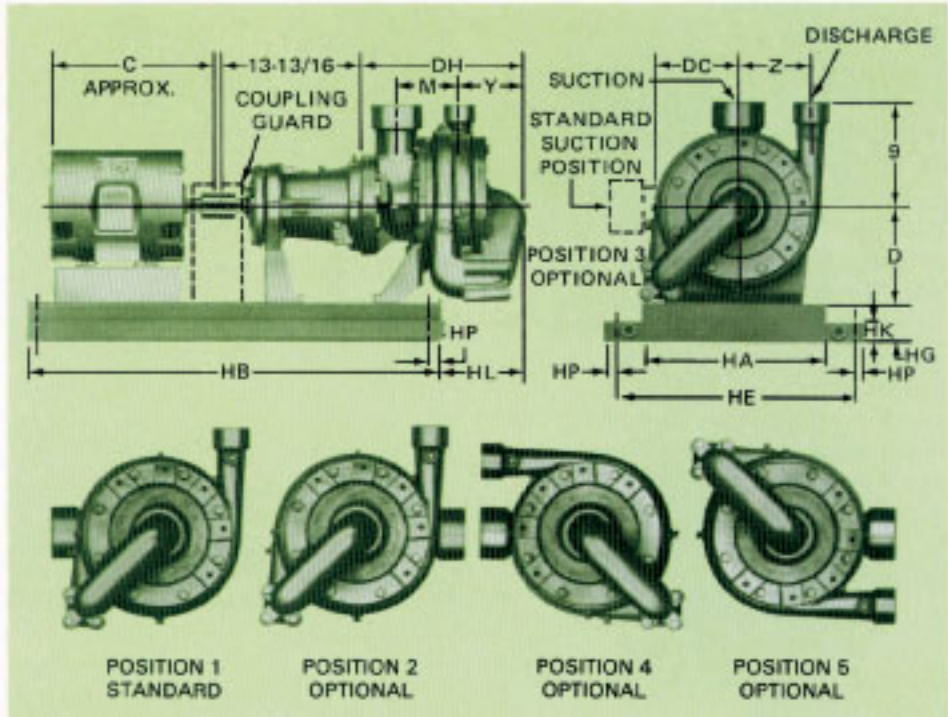

PUMP SIZE			D	DC	DH	HL	M	Y	Z
DISCH.	SUCT.	CASE BORE							
1½	3	10	8	7	14½	8	5¾	5¾	6¾
2	4	10	9	7¾	15½	9¾	6¾	6¾	6¾

PUMP MODEL	BASE NUMBER	WEIGHT POUNDS	HA	HB	HE	HG	HP	HK	POWER FRAME WEIGHT (LBS.)	
									2	3
374	5	56	11	36½	15%	3	1½	1½	82	87
	6	68	11	42½	15%	3	1½			
	8	96	14	42½	19	3	1½			
	9	110	14	48½	19	3	¾			
	11	164	18	46½	25½	4	1½			
12	192	18	54½	25%	4	1½	2			

- NOTES:**
- Dimensions and weights are approximate.
  - All dimensions are in inches and may vary ± 1/16".
  - Frame sizes, "C" dimension and motor weight are for open drip-proof motors only.
  - Conduit box is shown in approximate position. Dimensions are not specified as they vary with each motor manufacturer.
  - Add pump, base and motor weight for unit weight.
  - Not for construction purposes unless certified.
  - Discharge position No. 1 is furnished as standard unless otherwise specified.
  - Aurora Pump reserves the right to make revisions to its products and their specifications, and to this bulletin and related information, without notice.
  - Note: Power frame selection can be made from the range charts.

MOTOR FRAME	HORSEPOWER		MOTOR WEIGHT IN LBS	C	BASE NUMBER
	3500 RPM	1750 RPM			
143T	—	1	30	12	5
145T	—	1½-2	35	13	5
182T	—	3	45	13	5
184T	—	5	50	14	5
213T	10	7½	120	16	5
215T	15	10	144	18	6
254T	20	15	217	21	8
256T	25	—	246	23	9
284TS	30	—	320	22	9
286TS	40	—	351	24	9
324TS	50	—	442	25	11
326TS	60	—	522	26	11
364TS	75	—	540	27	11
365TS	100	—	590	28	12

— Your Authorized Local Distributor —



**MARKETING & SALES:**  
 800 HOPKIN ROAD • NORTH AURORA, ILLINOIS U.S.A. • 60542  
 PHONE: (630) 859-7000 U.S.A./CANADA FAX: (630) 859-7040  
 WORLDWIDE FAX: (630) 859-1226  
 WEB: www.aurorapump.com  
 EMAIL: aurora\_info@pumps.aurora.com  
**AURORA MFG. PLANT:**  
 800 HOPKIN ROAD • NORTH AURORA, ILLINOIS U.S.A. • 60542  
 SALES OFFICES IN ALL MAJOR CITIES AND COUNTRIES  
 Refer to "Pumps" in yellow pages of your phone directory for your local Distributor.