

ap

AURORA PUMP A member of PENTAIR PUMP GROUP

BULLETIN 220/REV. K

220 SERIES

**SINGLE STAGE
CONDENSATE AND
BOILER FEED PUMPS**

AURORA PUMP

CAPACITIES TO 180 G.P.M.
HEADS TO 170 FEET
TEMPERATURES TO 200° F.

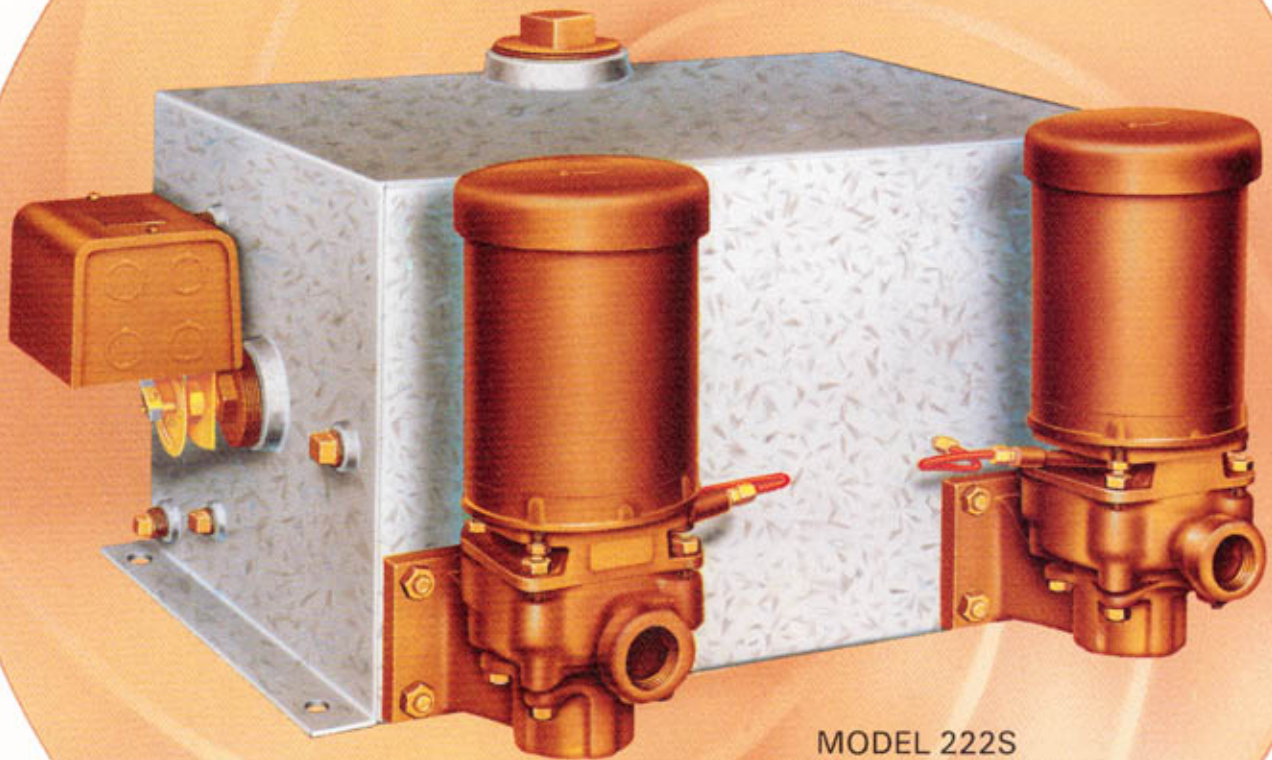

MODEL 222S
(Galvanized receiver optional)

ap AURORA®
Pentair Pump Group

INTRODUCTION AURORA CONDENSATE PUMPS

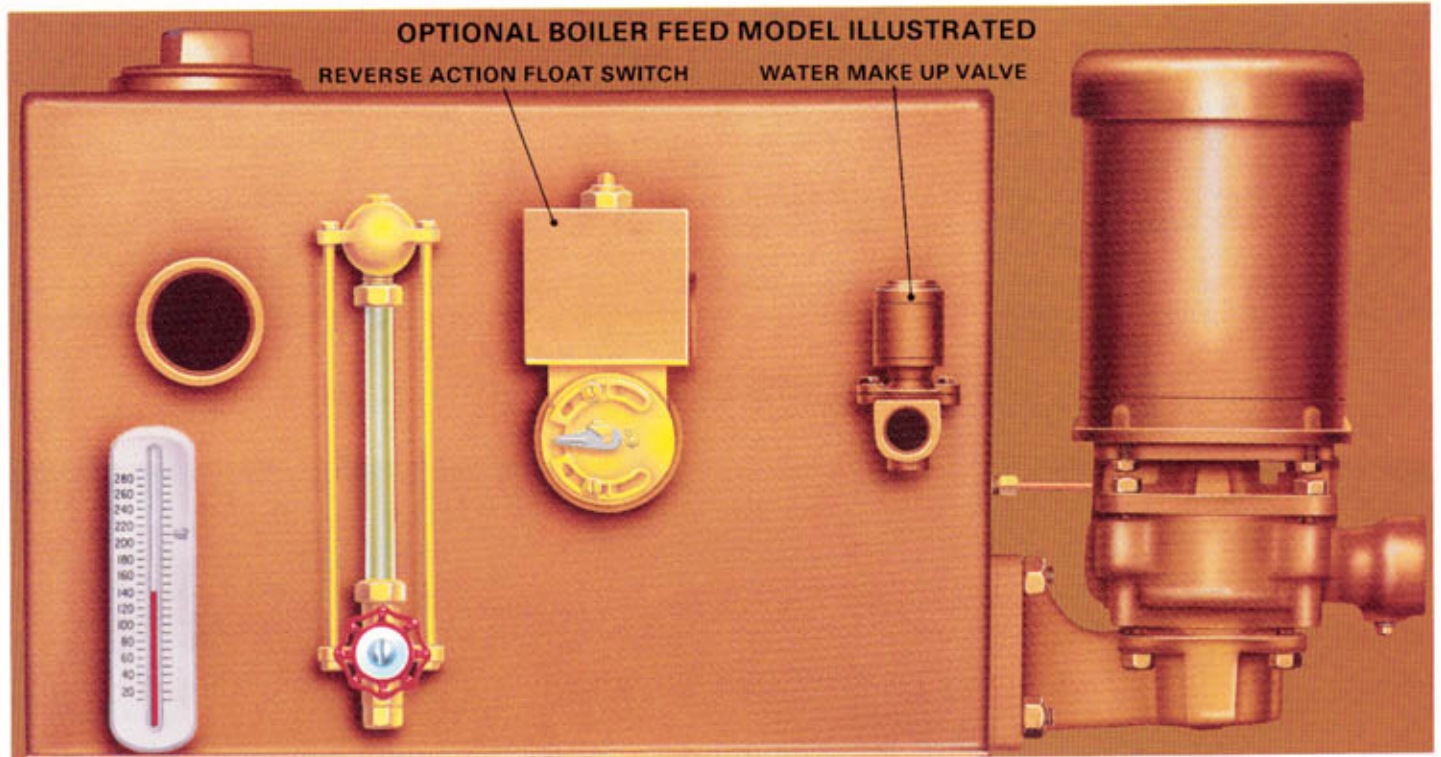

Condensate units provide for an automatic return of hot water condensation from radiators, coils, pipe, etc., to high or low pressure boilers. They are also utilized in industrial complexes for returning liquids to overhead storage tanks of gravitational circulating systems as well as many other unique uses. In a Duplex system, single pump operation provides service when capacity and demand calls for normal service. The two Model 323 pumps used in the system operate alternately to

extend the life of both pumps. Both pumps operate simultaneously when service demands exceed the capabilities of a single pump. Walls are 3/16" to insure long life. Threaded inlet, vent, drain and gauge glass connections are provided. Included are mounting holes for bolting to floor or base. COMPACT DESIGN utilizes a minimum amount of floor space and will mount along a wall or in a corner. The unit bolts directly to the floor or foundation with four easy to

reach mounting holes and provide low return line connections. Both pumps on a Duplex unit mount on the front of the receiver for easy discharge piping, wiring and maintenance. Several combinations of pump discharge nozzle and inlet connections provide many variables. There are two condensate unit return pipeline inlet openings located on opposite ends. Steel receivers have an additional 4" vent on top. Corrosion resistant galvanized steel receivers are available.

QUICK REFERENCE 220 SERIES FEATURE SELECTOR

STANDARD

Quality Aurora vertical pumps, steel or cast iron receiver with inlet, vent, drain and gauge glass connections. Min. wall thickness 3/16".
 Simplex pump with float switch
 Bronze fitted pump construction
 316 Stainless mechanical seal with Buna-N, Ni-Resist & carbon parts
 Vacuum cast, enclosed, dynamically balanced impeller
 Case wearing ring
 Back pull-out casing
 Factory assembled

OPTIONAL

Duplex pumps with combination float switch and alternator
 Control panel prewired
 Alternate discharge positions
 Thermometer
 Gauge glass assembly. (std. BF. units)
 Pressure gauges
 Inlet 3-way strainer valve with on-off-by-pass adjustments
 Special units
 Bronze shut-off valves
CAST IRON RECEIVERS UP TO 35 GALLON CAPACITY

UNIT FEATURES

1 LONG LIFE FABRICATED STEEL RECEIVER minimizes corrosion. Galvanized steel, or cast iron receivers are optionally available. Walls are 3/16" to insure long life. Threaded inlet vent, drain and gauge glass connections are provided. Included are mounting holes for bolting to floor or base. **2 BACK ANGLE THERMOMETER** provides accurate readings from 40° to 260°F and is optionally avail-

able. **3 BRASS WATER LEVEL GAUGE** glass assembly is furnished optionally, complete with shut-off valve and protector rods. **4 TROUBLEFREE FLOAT SWITCH** has adjustable travel to permit 1-1/2 times maximum return rate between stops. Combination float switch and alternator is standard on Duplex condensate units. **5 INTERCHANGEABLE DESIGN** provides future system expansion. All

receivers are fitted for Duplex operation. If requirements change, the second pump can be easily added without receiver modification. **6 STAINLESS STEEL SHAFT** is designed for minimum deflection, not to exceed .002" at the sealing faces at maximum load. Average bearing life is 10 years. **7 BACK PULL-OUT CASE DESIGN** simplifies disassembly. The suction base and discharge piping or

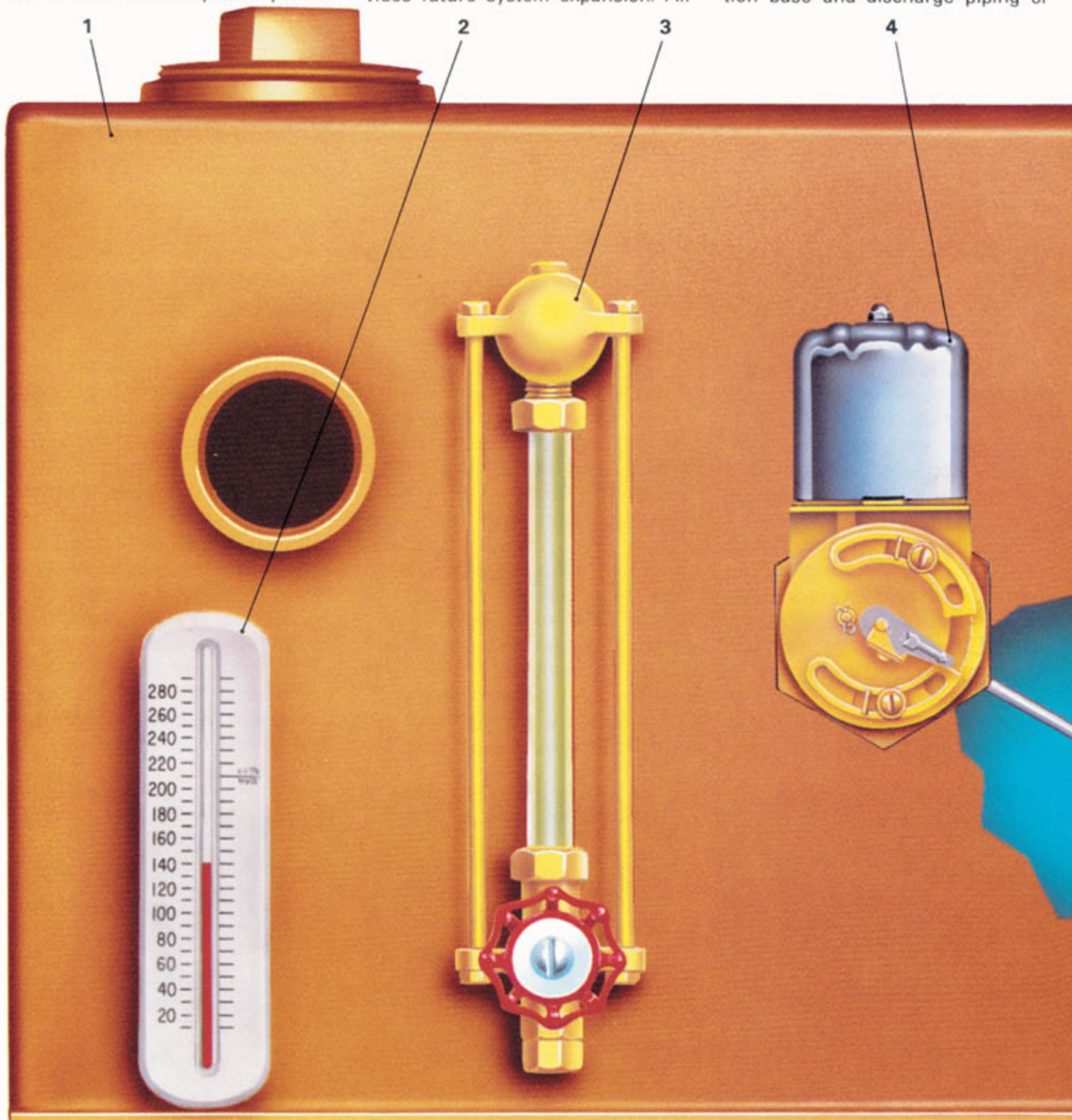

alignment is not disturbed as the casing remains in the pipe line. An "O" ring seals the casing to assure maximum trouble-free sealing. **8 LOW NOISE LEVEL** operation vertical close coupled motors are built to Aurora Pump's exacting quality control specifications. **9 HIGH TEMPERATURE** mechanical seal has carbon against Ni-Resist face for optimum hot water performance. Long life is assured

with 316 stainless steel metal parts and "Buna-N" elastomers. A relief line provides adequate venting of the seal chamber and circulation to the seal faces. **10 DYNAMICALLY BALANCED IMPELLER** is keyed to the shaft and secured by a capscrew and washer. Vacuum casting and quality controlled manufacturing process assures consistently high performance. Enclosed design provides high-

est efficiency and lowest wear for long trouble-free service life. **11 BRONZE WEAR RING** provides a positive seal, minimizes leakage losses, and in case of wear, ring is easily and inexpensively replaced. **12 COMPACT VERTICAL PUMPS** provide a low suction inlet and protect the motor from flooding. Centerline discharge minimizes pipe strain and is available in four alternate piping combinations.

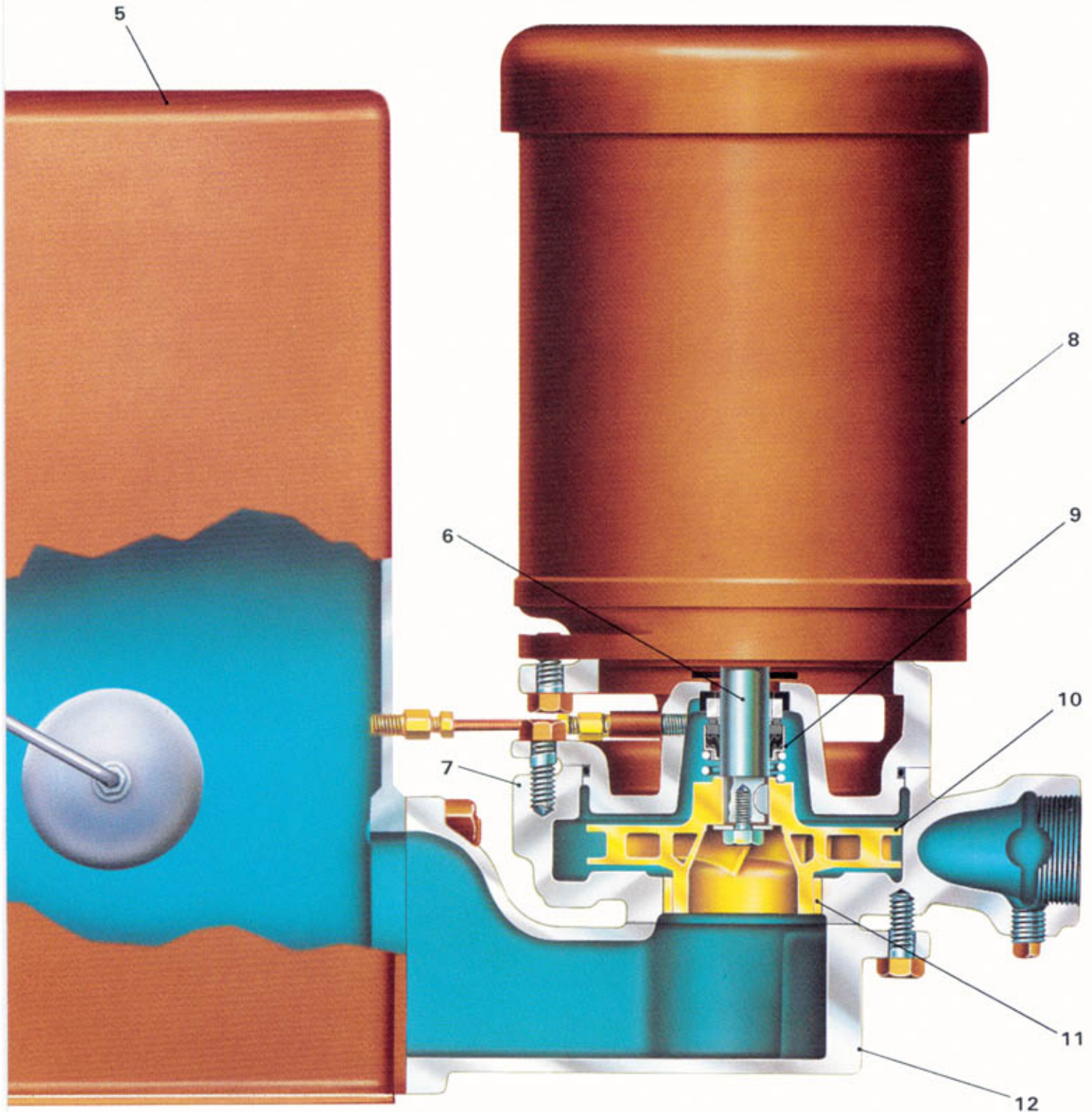

CONDENSATE SELECTION TABLES

3500 RPM				Receiver Capacity		Disch.	* I N L E T	† V E N T	Simplex (Note 1) MODEL 221		Duplex (Note 1) MODEL 222	
EDR	PSIG	G P M	Mtr. H.P.	Spx. 221	Dup. 222				Unit No.	Wgt. (Lbs.)	Unit No.	Wgt. (Lbs.)
500 TO 3,000	10	6	1/2	6	10	1	2	2	3C10S2	160	3C10D2	275
	15	6	1/2	6	10	1	2	2	3C15S2	160	3C15D2	275
	20	6	1/2	6	10	1	2	2	3C20S2	160	3C20D2	275
	25	6	1/2	6	10	1	2	2	3C25S2	170	3C25D2	290
	30	6	1/2	6	10	1/4	2	2	3C30S2	165	3C30D2	285
	40	6	3/4	6	10	1/4	2	2	3C40S2	165	3C40D2	285
	50	6	1	6	10	1/4	2	2	3C50S2	185	3C50D2	320
4,000 TO 6,000	60	6	1	6	10	1/4	2	2	3C60S2	190	3C60D2	330
	75	6	2	6	10	1/4	2	2	3C75S2	225	3C75D2	400
	10	12	1/2	10	10	1	2	2	6C10S2	210	6C10D2	275
	15	12	1/2	10	10	1	2	2	6C15S2	210	6C15D2	275
	20	12	1/2	10	10	1	2	2	6C20S2	210	6C20D2	275
	25	12	1/2	10	10	1	2	2	6C25S2	220	6C25D2	290
	30	12	1/2	10	10	1/4	2	2	6C30S2	210	6C30D2	285
8,000 TO 10,000	40	12	3/4	10	10	1/4	2	2	6C40S2	215	6C40D2	290
	50	12	1	10	10	1/4	2	2	6C50S2	230	6C50D2	320
	60	12	1 1/2	10	10	1/4	2	2	6C60S2	260	6C60D2	375
	75	12	2	10	10	1/4	2	2	6C75S2	270	6C75D2	400
	10	15	1/2	15	15	1	2	2	10C10S2	260	10C10D2	325
	15	15	1/2	15	15	1	2	2	10C15S2	260	10C15D2	325
	20	15	1/2	15	15	1	2	2	10C20S2	260	10C20D2	325
15,000 (Note 1)	25	15	1/2	15	15	1	2	2	10C25S2	265	10C25D2	340
	30	15	1/2	15	15	1/4	2	2	10C30S2	260	10C30D2	335
	40	15	3/4	15	15	1/4	2	2	10C40S2	265	10C40D2	340
	50	15	1	15	15	1/4	2	2	10C50S2	280	10C50D2	370
	60	15	1 1/2	15	15	1/4	2	2	10C60S2	310	10C60D2	425
	75	15	2	15	15	1/4	2	2	10C75S2	320	10C75D2	450
	10	22.5	1/2	25	25	1	2	2	15S10S2	193	15S10D2	243
20,000 (Note 1)	15	22.5	1/2	25	25	1	2	2	15S15S2	193	15S15D2	243
	20	22.5	1/2	25	25	1	2	2	15S20S2	193	15S20D2	243
	25	22.5	1/2	25	25	1	2	2	15S25S2	216	15S25D2	289
	30	22.5	3/4	25	25	1/4	2	2	15S30S2	224	15S30D2	305
	40	22.5	1	25	25	1/4	2	2	15S40S2	224	15S40D2	305
	50	22.5	1 1/2	25	25	1/4	2	2	15S50S2	233	15S50D2	323
	60	22.5	1 1/2	25	25	1/4	2	2	15S60S2	243	15S60D2	343
25,000 (Note 1)	75	22.5	3	25	25	1/4	2	2	15S75S2	259	15S75D2	375
	10	30	1/2	25	25	1	2	2	20S10S2	193	20S10D2	243
	15	30	1/2	25	25	1	2	2	20S15S2	193	20S15D2	243
	20	30	1/2	25	25	1	2	2	20S20S2	216	20S20D2	289
	25	30	1/2	25	25	1	2	2	20S25S2	216	20S25D2	289
	30	30	1	25	25	1/4	2	2	20S30S2	224	20S30D2	305
	40	30	1 1/2	25	25	1/4	2	2	20S40S2	233	20S40D2	323
30,000 (Note 1)	50	30	1 1/2	25	25	1/4	2	2	20S50S2	237	20S50D2	331
	60	30	2	25	25	1/4	2	2	20S60S2	258	20S60D2	373
	75	30	3	25	25	1/4	2	2	20S75S2	259	20S75D2	375
	10	37.5	1/2	35	35	1	3	3	25S10S2	193	25S10D2	243
	15	37.5	1/2	35	35	1	3	3	25S15S2	193	25S15D2	243
	20	37.5	1/2	35	35	1	3	3	25S20S2	240	25S20D2	313
	25	37.5	3/4	35	35	1	3	3	25S25S2	250	25S25D2	333
25,000 (Note 1)	30	37.5	1	35	35	1	3	3	25S30S2	250	25S30D2	333
	40	37.5	1 1/2	35	35	1	3	3	25S40S2	261	25S40D2	355
	50	37.5	1 1/2	35	35	1	3	3	25S50S2	261	25S50D2	355
	60	37.5	3	35	35	1/4	3	3	25S60S2	283	25S60D2	399
	75	37.5	5	35	35	1/4	3	3	25S75S2	300	25S75D2	433
	10	45	1/2	35	35	1	3	3	30S10S2	217	30S10D2	267
	15	45	1/2	35	35	1	3	3	30S15S2	240	30S15D2	313
30,000 (Note 1)	20	45	1/2	35	35	1	3	3	30S20S2	243	30S20D2	313
	25	45	3/4	35	35	1	3	3	30S25S2	250	30S25D2	333
	30	45	1	35	35	1/4	3	3	30S30S2	250	30S30D2	333
	40	45	1 1/2	35	35	1	3	3	30S40S2	261	30S40D2	355
	50	45	3	35	35	2	3	3	30S50S2	283	30S50D2	399
	60	45	3	35	35	1/4	3	3	30S60S2	283	30S60D2	399
	75	45	5	35	35	1/4	3	3	30S75S2	300	30S75D2	433

25 and 35 gallon receivers are also available in cast iron. Substitute a "C" for the first "S" in the unit number required. Example: 25S10S2 would be 25C10S2 for cast iron. Add approx. 150 lbs. to unit weight.
(2) Cast iron receivers not available.

3500 RPM				Receiver Capacity		Disch.	* I N L E T	† V E N T	Simplex (Note 1) MODEL 221		Duplex (Note 1) MODEL 222	
EDR	PSIG	G P M	Mtr. H.P.	Spx. 221	Dup. 222				Unit No.	Wgt. (Lbs.)	Unit No.	Wgt. (Lbs.)
40,000 (Note 2)	10	60	1/2	55	55	1/4	3	3	40S10S2	253	40S10D2	310
	15	60	1/2	55	55	1/4	3	3	40S15S2	265	40S15D2	360
	20	60	3/4	55	55	1/4	3	3	40S20S2	275	40S20D2	360
	25	60	1	55	55	1/4	3	3	40S25S2	280	40S25D2	380
	30	60	1 1/2	55	55	1/4	3	3	40S30S2	295	40S30D2	400
	40	60	3	55	55	1/4	3	3	40S40S2	315	40S40D2	430
	50	60	5	55	55	1/4	3	3	40S50S2	330	40S50D2	460
50,000 (Note 2)	60	60	5	55	55	1/4	3	3	40S60S2	330	40S60D2	460
	75	60	5	55	55	1/4	3	3	40S75S2	330	40S75D2	460
	10	75	1/2	70	70	1/4	3	3	50S10S2	293	50S10D2	349
	15	75	1/2	70	70	1/4	3	3	50S15S2	320	50S15D2	403
	20	75	1	70	70	1/4	3	3	50S20S2	320	50S20D2	403
	25	75	1 1/2	70	70	1/4	3	3	50S25S2	329	50S25D2	421
	30	75	3	70	70	2	3	3	50S30S2	355	50S30D2	473
60,000 (Note 2)	40	75	3	70	70	2	3	3	50S40S2	353	50S40D2	469
	50	75	5	70	70	2	3	3	50S50S2	357	50S50D2	477
	60	75	5	70	70	1/4	3	3	50S60S2	370	50S60D2	503
	10	90	1	70	70	1/2	3	3	60S10S2	317	60S10D2	397
	15	90	1 1/2	70	70	1/2	3	3	60S15S2	326	60S15D2	415
	20	90	2	70	70	2	3	3	60S20S2	345	60S20D2	453
	25	90	2	70	70	2	3	3	60S25S2	348	60S25D2	459
70,000 (Note 2)	30	90	3	70	70	2	3	3	60S30S2	355	60S30D2	473
	40	90	3	70	70	2	3	3	60S40S2	353	60S40D2	469
	50	90	5	70	70	2	3	3	60S50S2	357	60S50D2	477
	55	90	5	70	70	2	3	3	60S55S2	357	60S55D2	477
	10	105	1 1/2	125	125	1/2	3	3	70S10S2	421	70S10D2	510
	15	105	1 1/2	125	125	1/2	3	3	70S15S2	421	70S15D2	510
	20	105	2	125	125	2	3	3	70S20S2	440	70S20D2	548
80,000 (Note 2)	25	105	3	125	125	2	3	3	70S25S2	450	70S25D2	568
	30	105	3	125	125	2	3	3	70S30S2	450	70S30D2	568
	40	105	5	125	125	2	3	3	70S40S2	452	70S40D2	572
	50	105	5	125	125	2	3	3	70S50S2	452	70S50D2	572
	10	120	1 1/2	125	125	1/2	3	3	80S10S2	421	80S10D2	510
	15	120	1 1/2	125	125	2	3	3	80S15S2	425	80S15D2	518
	20	120	2	125	125	2	3	3	80S20S2	440	80S20D2	548
90,000 (Note 2)	25	120	3	125	125	2	3	3	80S25S2	450	80S25D2	568
	30	120	3	125	125	2	3	3	80S30S2	450	80S30D2	568
	40	120	5	125	125	2	3	3	80S40S2	452	80S40D2	572
	50	120	5	125	125	2	3	3	80S50S2	452	80S50D2	572
	10	135	2	125	125	1/2	3	3	90S10S2	441	90S10D2	550
	15	135	2	125	125	2	3	3	90S15S2	440	90S15D2	548
	20	135	3	125	125	2	3	3	90S20S2	450	90S20D2	568
100,000 (Note 2)	25	135	3	125	125	2	3	3	90S25S2	450	90S25D2	568
	30	135	5	125	125	2	3	3	90S30S2	457	90S30D2	582
	40	135	5	125	125	2	3	3	90S40S2	452	90S40D2	572
	50	135	7 1/2	125	125	2	3	3	90S50S2	457	90S50D2	582
	15	150	2	125	125	2	3	3	100S15S2	440	100S15D2	548
	20	150	3	125	125	2	3	3	100S20S2	450	100S20D2	568
	25	150	5	125	125	2	3	3	100S25S2	457	100S25D2	582
110,000 (Note 2)	30	150	5	125	125	2	3	3	100S30S2	457	100S30D2	582
	40	150	5	125	125	2	3	3	100S40S2	452	100S40D2	572

CONDENSATE/BOILER FEED SELECTION TABLES AND OPTIONAL EQUIPMENT

1750 RPM		Receiver Capacity		Disch.	* I N L E T	† V E N T	Simplex (Note 1) MODEL 221		Duplex (Note 1) MODEL 222			
EDR	PSIG	G P M	Mtr. H.P.				Spx. 221	Dup. 222	Unit No.	Wgt. (Lbs.)	Unit No.	Wgt. (Lbs.)
500 TO 3,000	10	6	1/2	6	10	3/4	2	2	3C10S4	165	3C10D4	280
	15	6	1/2	6	10	3/4	2	2	3C15S4	180	3C15D4	310
	20	6	1/2	6	10	3/4	2	2	3C20S4	185	3C20D4	315
	25	6	3/4	6	10	1 1/4	2	2	3C25S4	225	3C25D4	395
4,000 TO 6,000	30	6	3/4	6	10	1 1/4	2	2	3C30S4	225	3C30D4	395
	10	12	1/2	10	10	3/4	2	2	6C10S4	210	6C10D4	280
	15	12	1/2	10	10	3/4	2	2	6C15S4	225	6C15D4	310
	20	12	1/2	10	10	3/4	2	2	6C20S4	225	6C20D4	315
8,000 TO 10,000	25	12	3/4	10	10	1 1/4	2	2	6C24S4	265	6C25D4	390
	30	12	3/4	10	10	1 1/4	2	2	6C30S4	265	6C30D4	390
	10	15	1/2	15	15	3/4	2	2	10C10S4	260	10C10D4	330
	15	15	1/2	15	15	3/4	2	2	10C15S4	275	10C15D4	365
15,000 (Note 1)	20	15	1/2	15	15	3/4	2	2	10C20S4	295	10C20D4	400
	25	15	3/4	15	15	1 1/4	2	2	10C25S4	315	10C25D4	440
	30	15	3/4	15	15	1 1/4	2	2	10C30S4	315	10C30D4	440
	10	22.5	1/2	25	25	1	2	2	15S10S4	201	15S10D4	259
20,000 (Note 1)	15	22.5	1/2	25	25	3/4	2	2	15S15S4	207	15S15D4	271
	20	22.5	3/4	25	25	1 1/4	2	2	15S20S4	226	15S20D4	309
	25	22.5	3/4	25	25	1 1/4	2	2	15S25S4	236	15S25D4	329
	30	22.5	1	25	25	1 1/4	2	2	15S30S4	251	15S30D4	359
25,000 (Note 1)	10	30	1/2	25	25	1	2	2	20S10S4	201	20S10D4	259
	15	30	1/2	25	25	3/4	2	2	20S15S4	224	20S15D4	305
	20	30	1/2	25	25	1 1/4	2	2	20S20S4	226	20S20D4	309
	25	30	3/4	25	25	1 1/4	2	2	20S25S4	236	20S25D4	329
30,000 (Note 1)	30	30	1	25	25	1 1/4	2	2	20S30S4	251	20S30D4	359
	10	37.5	1/2	35	35	1 1/4	3	3	25S10S4	233	25S10D4	299
	15	37.5	1/2	35	35	1 1/4	3	3	25S15S4	250	25S15D4	333
	20	37.5	3/4	35	35	1 1/4	3	3	25S20S4	260	25S20D4	353
40,000 (Note 2)	25	37.5	1	35	35	1 1/4	3	3	25S25S4	275	25S25D4	383
	30	37.5	1 1/2	35	35	1 1/4	3	3	25S30S4	275	25S30D4	383
	10	45	1/2	35	35	1 1/4	3	3	30S10S4	233	30S10D4	299
	15	45	1/2	35	35	1 1/4	3	3	30S15S4	250	30S15D4	333
50,000 (Note 2)	20	45	3/4	35	35	1 1/4	3	3	30S20S4	265	30S20D4	363
	25	45	1	35	35	1 1/4	3	3	30S25S4	275	30S25D4	383
	30	45	1 1/2	35	35	1 1/4	3	3	30S30S4	275	30S30D4	383
	10	60	1/2	55	55	1 1/4	3	3	40S10S4	277	40S10D4	360
60,000 (Note 2)	15	60	3/4	55	55	1 1/4	3	3	40S15S4	287	40S15D4	380
	20	60	1	55	55	1 1/2	3	3	40S20S4	288	40S20D4	382
	25	60	1 1/2	55	55	1 1/4	3	3	40S25S4	302	40S25D4	410
	10	75	3/4	70	70	1 1/2	3	3	50S10S4	331	50S10D4	425
70,000 (Note 2)	15	75	3/4	70	70	1 1/2	3	3	50S15S4	331	50S15D4	425
	20	75	1	70	70	1 1/2	3	3	50S20S4	331	50S20D4	425
	10	90	3/4	70	70	1 1/2	3	3	60S10S4	331	60S10D4	425
	15	90	1	70	70	1 1/2	3	3	60S15S4	331	60S15D4	425
80,000 (Note 2)	20	90	2	70	70	2	3	3	60S20S4	355	60S20D4	473
	10	105	1	125	125	1 1/2	3	3	70S10S4	426	70S10D4	520
	15	105	1 1/2	125	125	1 1/2	3	3	70S15S4	435	70S15D4	538
	20	105	2	125	125	2	3	3	70S20S4	450	70S20D4	568
90,000 (Note 2)	10	120	1	125	125	1 1/2	3	3	80S10S4	426	80S10D4	520
	15	120	1 1/2	125	125	1 1/2	3	3	80S15S4	435	80S15D4	538
	20	120	2	125	125	2	3	3	80S20S4	450	80S20D4	568
	10	135	1 1/2	125	125	1 1/2	3	3	90S10S4	435	90S10D4	538
100,000 (Note 2)	15	135	1 1/2	125	125	2	3	3	90S15S4	447	90S15D4	562
	20	135	2	125	125	2	3	3	90S20S4	450	90S20D4	568
	10	150	1 1/2	125	125	2	3	3	100S10S4	447	100S10D4	562
	15	150	2	125	125	2	3	3	100S15S4	450	100S15D4	568
	20	150	3	125	125	2	3	3	100S20S4	453	100S20D4	574

• 6 gallon receiver has 3/4" inlet, 1 1/2" vent.
 † "S" model numbers (steel receivers) have additional 4" vent.
 (1) 25 and 35 gallon receivers are also available in cast iron. Substitute a "C" for the first "S" in the unit number required. Example: 25S10S4 would be 25C10S4 for cast iron. Add approx. 150 lbs. to unit weight.
 (2) Cast iron receivers not available.

LOW PRESSURE BOILER FEED SELECTIONS STEEL RECEIVERS ONLY 1750 RPM 15 PSIG MODEL 323 — 3/4 x 1 x 78

Boiler H.P. Size	Evap. Rate GPM	Pump Cap. GPM	Mtr. H.P.	Simplex		Duplex		Dual		Receiver Cap. — Gals.		
				Unit No.	Wgt.	Unit No.	Wgt.	Unit No.	Wgt.	Simplex	Duplex	Dual
15	1.0	6	1/3	BFSX15S4	199	BFDX15S4	257	BFDL15S4	281	25	25	35
20	1.4	6	1/3	BFSX20S4	199	BFDX20S4	257	BFDL20S4	308	25	25	55
25	1.7	6	1/3	BFSX25S4	223	BFDX25S4	281	BFDL25S4	308	35	35	55
30	2.1	6	1/3	BFSX30S4	223	BFDX30S4	281	BFDL30S4	308	35	35	55
40	2.8	6	1/3	BFSX40S4	223	BFDX40S4	281	BFDL40S4	351	35	35	70
50	3.5	12	1/2	BFSX50S4	250	BFDX50S4	308	BFDL50S4	446	55	55	125
60	4.2	12	1/2	BFSX60S4	250	BFDX60S4	308	BFDL60S4	446	55	55	125
70	4.8	12	1/2	BFSX70S4	293	BFDX70S4	351	BFDL70S4	610	70	70	200
80	5.5	12	1/2	BFSX80S4	293	BFDX80S4	351	BFDL80S4	610	70	70	200
100	6.9	15	1/2	BFSX100S4	388	BFDX100S4	446	BFDL100S4	610	125	125	200
125	8.6	15	1/2	BFSX125S4	388	BFDX125S4	446	—	—	125	125	—
150	10.7	22.5	1/2	BFSX150S4	552	BFDX150S4	610	—	—	200	200	—
200	13.8	30	3/4	BFSX200S4	552	BFDX200S4	610	—	—	200	200	—

Boiler H.P. Size	Evap. Rate GPM	Pump Cap. GPM	Mtr. H.P.	Simplex		Duplex		Dual		Receiver Cap. — Gals.		
				Unit No.	Wgt.	Unit No.	Wgt.	Unit No.	Wgt.	Simplex	Duplex	Dual
15	1.0	6	1/3	BFSX15S2	175	BFDX15S2	209	BFDL15S2	233	25	25	35
20	1.4	6	1/3	BFSX20S2	175	BFDX20S2	209	BFDL20S2	260	25	25	55
25	1.7	6	1/3	BFSX25S2	199	BFDX25S2	233	BFDL25S2	260	35	35	55
30	2.1	6	1/3	BFSX30S2	199	BFDX30S2	233	BFDL30S2	260	35	35	55
40	2.8	6	1/3	BFSX40S2	199	BFDX40S2	233	BFDL40S2	303	35	35	70
50	3.5	12	1/3	BFSX50S2	226	BFDX50S2	260	BFDL50S2	398	55	55	125
60	4.2	12	1/3	BFSX60S2	226	BFDX60S2	260	BFDL60S2	398	55	55	125
70	4.8	12	1/3	BFSX70S2	269	BFDX70S2	303	BFDL70S2	572	70	70	200
80	5.5	12	1/3	BFSX80S2	269	BFDX80S2	303	BFDL80S2	572	70	70	200
100	6.9	15	1/3	BFSX100S2	364	BFDX100S2	398	BFDL100S2	572	125	125	200
125	8.6	15	1/3	BFSX125S2	364	BFDX125S2	398	—	—	125	125	—
150	10.7	22.5	1/2	BFSX150S2	533	BFDX150S2	533	—	—	200	200	—
200	13.8	30	1/2	BFSX200S2	533	BFDX200S2	533	—	—	200	200	—

MAGNETIC STARTERS with overload protection are conveniently mounted to a support on top of the receiver and wired to the pump motors and float switch or combination float switch and alternator. The starters shall be mounted in a NEMA 1 enclosure. Reset button(s) and H-O-A switch(es) shall be provided outside the enclosure.

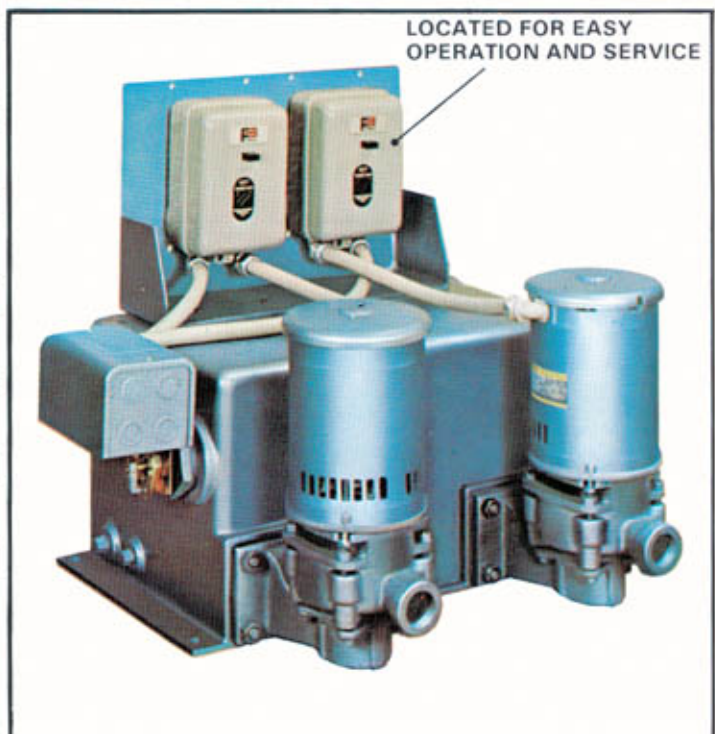

OPTIONAL SHUT-OFF VALVE FEATURES

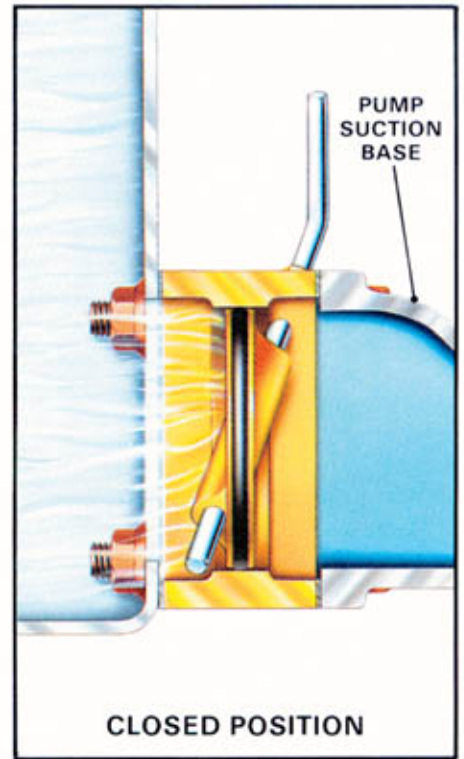
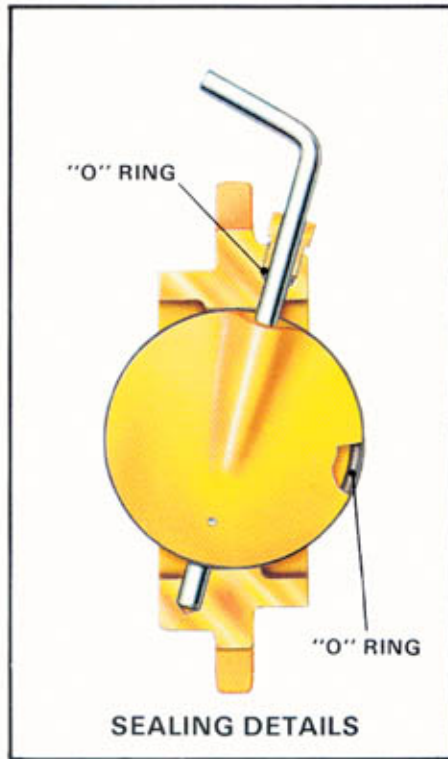

3-WAY VALVE provides for greater pump protection, easier, faster maintenance, and de-

pendable operation. With just a turn of the plug the water flow can be channeled through the

strainer, bypassed around the strainer (to allow the strainer to be cleaned), or be shut-off.

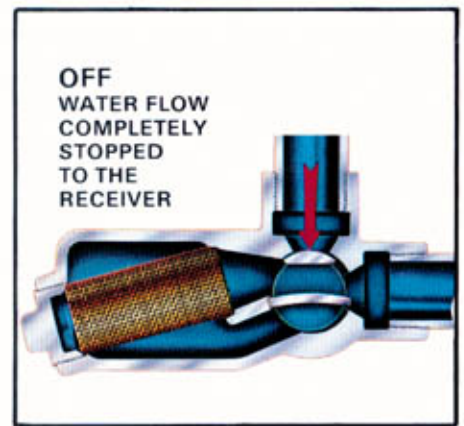
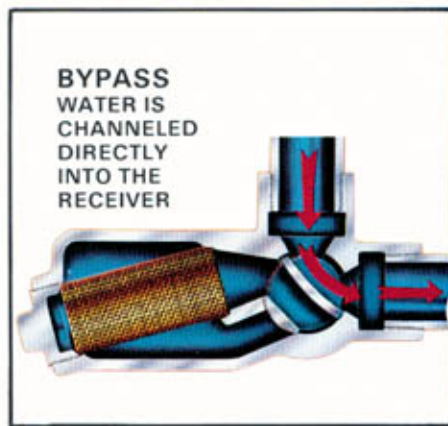

MOTOR SPECIFICATIONS

Drip-proof NEMA rated . . . stainless steel shaft, 3500 or 1750 R.P.M., dual voltage, single or three phase.

THREE PHASE — 60/50 Hertz, 200-230/480 volt
SINGLE PHASE — 60 Hertz, 115/230 volt. All 1-1/2 H.P. and smaller equipped with thermal overload protection.

Explosion-proof and totally enclosed motors also available.

NOTE: All motors used with 220 Series Condensation Return Units are built to Aurora Pump's specifications and must not exceed our specified vibration rating for low noise level operation. Not all motors available meet these rigid specifications — so, for best operating characteristics, make of motor will be selected by Aurora Pump only from approved sources.

MATERIAL OF CONSTRUCTION

PUMP PART	MATERIAL	
CASING	CAST IRON	ASTM A48
CASE WEARING RING	BRONZE	ASTM B62
IMPELLER	BRONZE	ASTM B62
MECHANICAL SEAL	316 ST. STL. METAL PARTS "BUNA-N" ELASTOMER PARTS. NI-RESIST SEAT & CARBON WASHER	
MOTOR BRACKET	CAST IRON	ASTM A48
MOTOR SHAFT	STAINLESS STEEL	AISI 416
RECEIVER	CAST IRON	ASTM A48
	STEEL	ASTM A569
SUCTION BASE	CAST IRON	ASTM A48

LIMITATIONS

MAX. RECEIVER INTERNAL PRESSURE	5 P.S.I.G.	MAXIMUM DISCHARGE PRESSURE	75 P.S.I.G.	MAX. TEMP. LIMIT ON PUMP SUCTION	200° F.
---------------------------------	------------	----------------------------	-------------	----------------------------------	---------

FITS IN CORNERS OR ALONG WALLS

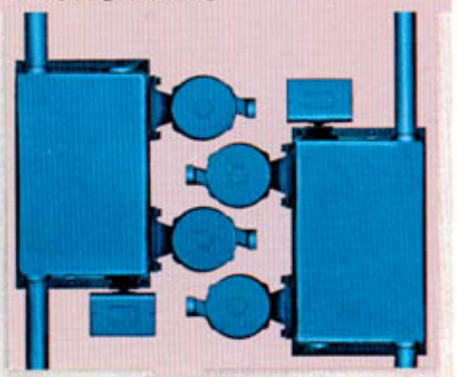

ENGINEERING SPECIFICATIONS

The contractor shall furnish (and install in location as shown on the plans) an Aurora 220 Series (Model 221 Cast Iron) (Model 221S Steel) (Simplex) — (Model 222 Cast Iron) (Model 222S Steel) (Duplex) (Condensate Return Unit) (Model BFSX (Simplex) — BFDX (Duplex) — BFDL (Dual) Low Pressure Boiler Feed Unit). Condensate unit for handling condensate returns from square feet of direct radiation, when discharging against a pressure of PSI at the pump. Boiler Feed Unit for handling boiler BHP of (GPM), when discharging against a pressure of 15 PSI at the pump. The unit shall consist of vertical flange mounted bronze fitted pumps) with a bronze case wearing ring and a mechanical seal with 316 stainless steel metal parts, "Buna-N" bellows, Ni-resist seat and carbon washer. The pump(s) to be close coupled to NEMA motor(s) of HP, phase, hertz, voltage, RPM, (D.P.) (T.E.) (Ex. Pr.) enclosure with stainless steel motor shaft. The motor(s) shall be designed to Aurora Pump specifications for vibration limits. The pump-motor combination(s) to be flange mounted to one (steel) (galvanized steel) (cast iron — condensate service only) receiver of gal. capacity. All receivers shall include inlet, vent, drain and gauge glass connections. BOILER FEED units include a reverse-actuation float switch operating a solenoid controlled water make-up valve (3/4"), (1") and a brass water level gauge glass assembly complete with shut-off valve and protector rods mounted to the receiver. One optional back angle thermometer shall be mounted to the receiver. A water type shut-off valve shall be secured between each pump suction base and the receiver. Optional brass water level gauge glass assembly and/or back angle thermometer shall be mounted to condensate receiver. **SIMPLEX CONDENSATE UNIT** to be furnished with one enclosed float switch assembly, connected to motor (single phase, 3/4 HP or less) or connected to a magnetic starter or optional combination starter for motor (single phase, 1 HP or larger and all three phase motors). **DUPLEX CONDENSATE UNIT** to be furnished with one combination float switch and mechanical alternator connected to motor (single phase, 3/4 HP or less) or two magnetic starters or one optional dual controller for motors (single phase, 1 HP or larger and all three phase motors). **SIMPLEX OR DUAL BOILER FEED UNIT** to be furnished without motor controls (single phase, 3/4 HP or less). **SIMPLEX (BFSX) unit** to be furnished with a magnetic starter or optional combination starter for motor (single phase, 1 HP or larger and all three phase motors). **DUAL (BFDL) unit** to be furnished with two magnetic starters or one optional dual controller for motors (single phase, 1 HP or larger and all three phase motors). **DUPLEX (BFDX) unit** to be furnished with electric alternator only in a NEMA 1 enclosure as standard for motors (single phase, 3/4 HP or less). **DUPLEX (BFDX) unit** to be furnished with one optional duplex controller, with electric alternator, for motors (single phase, 1 HP or larger and all three phase motors). The starters (controllers) shall be mounted in a (gasketed) NEMA 1 enclosure which is attached to the receiver.

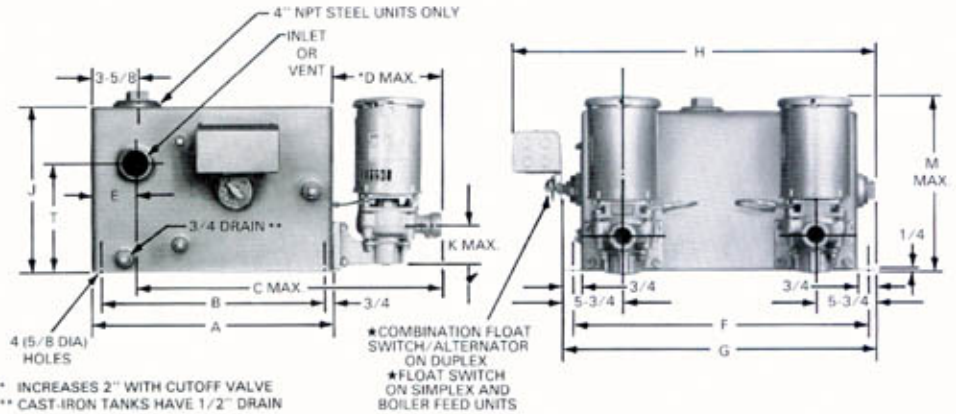

* INCREASES 2" WITH CUTOFF VALVE
 ** CAST-IRON TANKS HAVE 1/2" DRAIN

★ COMBINATION FLOAT SWITCH/ALTERNATOR ON DUPLEX
 ★ FLOAT SWITCH ON SIMPLEX AND BOILER FEED UNITS

UNIT NO.	SIMPLEX		DUPLEX		DUAL		A	B	C	D	E	F	G	H	J	K	M	T	Inlet and Vent	Rec. Gal. Cap.
	3000 RPM	1750 RPM	3500 RPM	1750 RPM	3500 RPM	1750 RPM														
3001001	3001004	17501004	N/A	N/A	N/A	N/A	11 1/2	10 1/2	28 1/2	10 3/4	5 1/2	18 1/2	13 1/2	17 1/2	11	4 1/4	2 1/2	9	1 1/2	6
3001002	3001004	17501004	N/A	N/A	N/A	N/A	15 1/2	14 1/2	32 1/2	16 1/2	7 1/2	20 1/2	14 1/2	21 1/2	11	4 1/4	2 1/2	9	2	10
N/A	N/A	N/A	3001002	17501002	N/A	N/A	15 1/2	14 1/2	32 1/2	16 1/2	7 1/2	20 1/2	14 1/2	21 1/2	11	4 1/4	2 1/2	9	2	10
N/A	N/A	N/A	3001002	17501002	N/A	N/A	15 1/2	14 1/2	32 1/2	16 1/2	7 1/2	20 1/2	14 1/2	21 1/2	11	4 1/4	2 1/2	9	2	10
1901001	1901004	1001004	1901002	1001002	N/A	N/A	14	12 1/2	30 1/2	16 1/2	7	19 1/2	12 1/2	18 1/2	10 1/2	4 1/4	2 1/2	10 1/2	2	15
1901002	1901004	1001004	1901002	1001002	N/A	N/A	14	12 1/2	30 1/2	16 1/2	7	19 1/2	12 1/2	18 1/2	10 1/2	4 1/4	2 1/2	10 1/2	2	15
1901001	1901004	1001004	1901002	1001002	N/A	N/A	20	18 1/2	36 1/2	18 1/2	10	24 1/2	16 1/2	22 1/2	12	4 1/4	2 1/2	10 1/2	2	25
1901002	1901004	1001004	1901002	1001002	N/A	N/A	20	18 1/2	36 1/2	18 1/2	10	24 1/2	16 1/2	22 1/2	12	4 1/4	2 1/2	10 1/2	2	25
2901001	2901004	1501004	2901002	1501002	N/A	N/A	22	20 1/2	38 1/2	18 1/2	11	26 1/2	18 1/2	24 1/2	12	4 1/4	2 1/2	12	3	35
2901002	2901004	1501004	2901002	1501002	N/A	N/A	22	20 1/2	38 1/2	18 1/2	11	26 1/2	18 1/2	24 1/2	12	4 1/4	2 1/2	12	3	35
3901001	3901004	2001004	3901002	2001002	N/A	N/A	22	20 1/2	38 1/2	18 1/2	11	26 1/2	18 1/2	24 1/2	12	4 1/4	2 1/2	12	3	35
3901002	3901004	2001004	3901002	2001002	N/A	N/A	22	20 1/2	38 1/2	18 1/2	11	26 1/2	18 1/2	24 1/2	12	4 1/4	2 1/2	12	3	35
4901001	4901004	2501004	4901002	2501002	N/A	N/A	24	22 1/2	40 1/2	18 1/2	11	28 1/2	18 1/2	26 1/2	12	4 1/4	2 1/2	12	3	35
4901002	4901004	2501004	4901002	2501002	N/A	N/A	24	22 1/2	40 1/2	18 1/2	11	28 1/2	18 1/2	26 1/2	12	4 1/4	2 1/2	12	3	35
5901001	5901004	3001004	5901002	3001002	N/A	N/A	24	22 1/2	40 1/2	18 1/2	11	28 1/2	18 1/2	26 1/2	12	4 1/4	2 1/2	12	3	35
5901002	5901004	3001004	5901002	3001002	N/A	N/A	24	22 1/2	40 1/2	18 1/2	11	28 1/2	18 1/2	26 1/2	12	4 1/4	2 1/2	12	3	35
6901001	6901004	3501004	6901002	3501002	N/A	N/A	26	24 1/2	42 1/2	18 1/2	11	30 1/2	18 1/2	28 1/2	12	4 1/4	2 1/2	12	3	35
6901002	6901004	3501004	6901002	3501002	N/A	N/A	26	24 1/2	42 1/2	18 1/2	11	30 1/2	18 1/2	28 1/2	12	4 1/4	2 1/2	12	3	35
7901001	7901004	4001004	7901002	4001002	N/A	N/A	26	24 1/2	42 1/2	18 1/2	11	30 1/2	18 1/2	28 1/2	12	4 1/4	2 1/2	12	3	35
7901002	7901004	4001004	7901002	4001002	N/A	N/A	26	24 1/2	42 1/2	18 1/2	11	30 1/2	18 1/2	28 1/2	12	4 1/4	2 1/2	12	3	35
8901001	8901004	4501004	8901002	4501002	N/A	N/A	28	26 1/2	44 1/2	18 1/2	11	32 1/2	18 1/2	30 1/2	12	4 1/4	2 1/2	12	3	35
8901002	8901004	4501004	8901002	4501002	N/A	N/A	28	26 1/2	44 1/2	18 1/2	11	32 1/2	18 1/2	30 1/2	12	4 1/4	2 1/2	12	3	35
9901001	9901004	5001004	9901002	5001002	N/A	N/A	28	26 1/2	44 1/2	18 1/2	11	32 1/2	18 1/2	30 1/2	12	4 1/4	2 1/2	12	3	35
9901002	9901004	5001004	9901002	5001002	N/A	N/A	28	26 1/2	44 1/2	18 1/2	11	32 1/2	18 1/2	30 1/2	12	4 1/4	2 1/2	12	3	35
10901001	10901004	5501004	10901002	5501002	N/A	N/A	30	28 1/2	46 1/2	18 1/2	11	34 1/2	18 1/2	32 1/2	12	4 1/4	2 1/2	12	3	35
10901002	10901004	5501004	10901002	5501002	N/A	N/A	30	28 1/2	46 1/2	18 1/2	11	34 1/2	18 1/2	32 1/2	12	4 1/4	2 1/2	12	3	35
11901001	11901004	6001004	11901002	6001002	N/A	N/A	30	28 1/2	46 1/2	18 1/2	11	34 1/2	18 1/2	32 1/2	12	4 1/4	2 1/2	12	3	35
11901002	11901004	6001004	11901002	6001002	N/A	N/A	30	28 1/2	46 1/2	18 1/2	11	34 1/2	18 1/2	32 1/2	12	4 1/4	2 1/2	12	3	35
12901001	12901004	6501004	12901002	6501002	N/A	N/A	32	30 1/2	48 1/2	18 1/2	11	36 1/2	18 1/2	34 1/2	12	4 1/4	2 1/2	12	3	35
12901002	12901004	6501004	12901002	6501002	N/A	N/A	32	30 1/2	48 1/2	18 1/2	11	36 1/2	18 1/2	34 1/2	12	4 1/4	2 1/2	12	3	35
13901001	13901004	7001004	13901002	7001002	N/A	N/A	32	30 1/2	48 1/2	18 1/2	11	36 1/2	18 1/2	34 1/2	12	4 1/4	2 1/2	12	3	35
13901002	13901004	7001004	13901002	7001002	N/A	N/A	32	30 1/2	48 1/2	18 1/2	11	36 1/2	18 1/2	34 1/2	12	4 1/4	2 1/2	12	3	35
14901001	14901004	7501004	14901002	7501002	N/A	N/A	34	32 1/2	50 1/2	18 1/2	11	38 1/2	18 1/2	36 1/2	12	4 1/4	2 1/2	12	3	35
14901002	14901004	7501004	14901002	7501002	N/A	N/A	34	32 1/2	50 1/2	18 1/2	11	38 1/2	18 1/2	36 1/2	12	4 1/4	2 1/2	12	3	35
15901001	15901004	8001004	15901002	8001002	N/A	N/A	34	32 1/2	50 1/2	18 1/2	11	38 1/2	18 1/2	36 1/2	12	4 1/4	2 1/2	12	3	35
15901002	15901004	8001004	15901002	8001002	N/A	N/A	34	32 1/2	50 1/2	18 1/2	11	38 1/2	18 1/2	36 1/2	12	4 1/4	2 1/2	12	3	35
16901001	16901004	8501004	16901002	8501002	N/A	N/A	36	34 1/2	52 1/2	18 1/2	11	40 1/2	18 1/2	38 1/2	12	4 1/4	2 1/2	12	3	35
16901002	16901004	8501004	16901002	8501002	N/A	N/A	36	34 1/2	52 1/2	18 1/2	11	40 1/2	18 1/2	38 1/2	12	4 1/4	2 1/2	12	3	35
17901001	17901004	9001004	17901002	9001002	N/A	N/A	36	34 1/2	52 1/2	18 1/2	11	40 1/2	18 1/2	38 1/2	12	4 1/4	2 1/2	12	3	35
17901002	17901004	9001004	17901002	9001002	N/A	N/A	36	34 1/2	52 1/2	18 1/2	11	40 1/2	18 1/2	38 1/2	12	4 1/4	2 1/2	12	3	35
18901001	18901004	9501004	18901002	9501002	N/A	N/A	38	36 1/2	54 1/2	18 1/2	11	42 1/2	18 1/2	40 1/2	12	4 1/4	2 1/2	12	3	35
18901002	18901004	9501004	18901002	9501002	N/A	N/A	38	36 1/2	54 1/2	18 1/2	11	42 1/2	18 1/2	40 1/2	12	4 1/4	2 1/2	12	3	35
19901001	19901004	10001004	19901002	10001002	N/A	N/A	38	36 1/2	54 1/2	18 1/2	11	42 1/2	18 1/2	40 1/2	12	4 1/4	2 1/2	12	3	35
19901002	19901004	10001004	19901002	10001002	N/A	N/A	38	36 1/2	54 1/2	18 1/2	11	42 1/2	18 1/2	40 1/2	12	4 1/4	2 1/2	12	3	35
20901001	20901004	10501004	20901002	10501002	N/A	N/A	40	38 1/2	56 1/2	18 1/2	11	44 1/2	18 1/2	42 1/2	12	4 1/4	2 1/2	12	3	35
20901002	20901004	10501004	20901002	10501002	N/A	N/A	40	38 1/2	56 1/2	18 1/2	11	44 1/2	18 1/2	42 1/2	12	4 1/4	2 1/2	12	3	35
21901001	21901004	11001004	21901002	11001002	N/A	N/A	40	38 1/2	56 1/2	18 1/2	11	44 1/2	18 1/2	42 1/2	12	4 1/4	2 1/2	12	3	35
21901002	21901004	11001004	21901002	11001002	N/A	N/A	40	38 1/2	56 1/2	18 1/2	11	44 1/2	18 1/2	42 1/2	12	4 1/4	2 1/2			