

Performance Curves for the 650 Series

MODEL/SIZE	R.P.M.	CATALOG PAGE	PDF PAGE
3 x 3 x 7	1750/1150	401	2
3 x 3 x 9	1750/1150	402	3
4 x 4 x 7	1750/1150	403	4
4 x 4 x 9A	1750/1150	404	5
4 x 4 x 9B	1750/1150	405	6
4 x 4 x 9B	875	406	7
4 x 4 x 12	1750/1150	407	8
4 x 4 x 12	875	408	9
4 x 6 x 15	1750/1150	409	10
4 x 6 x 15	875/700	410	11

3 x 3 x 7 SERIES 650A

ENCLOSED IMPELLER

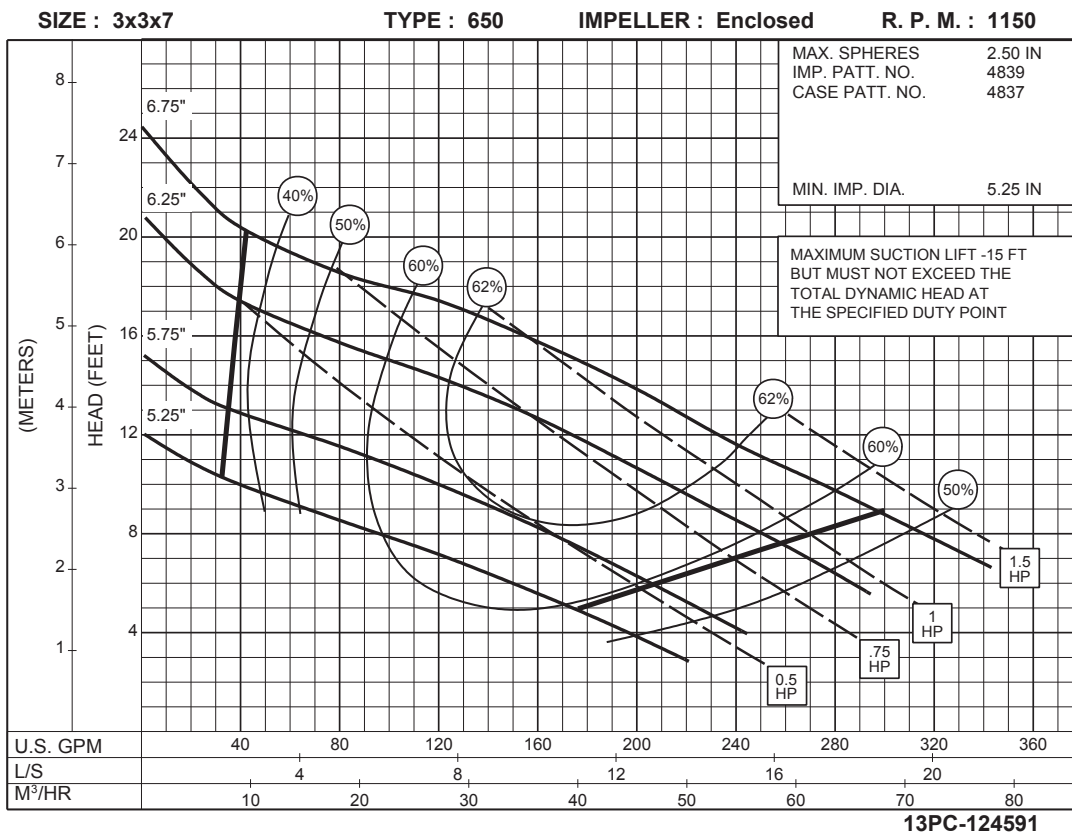
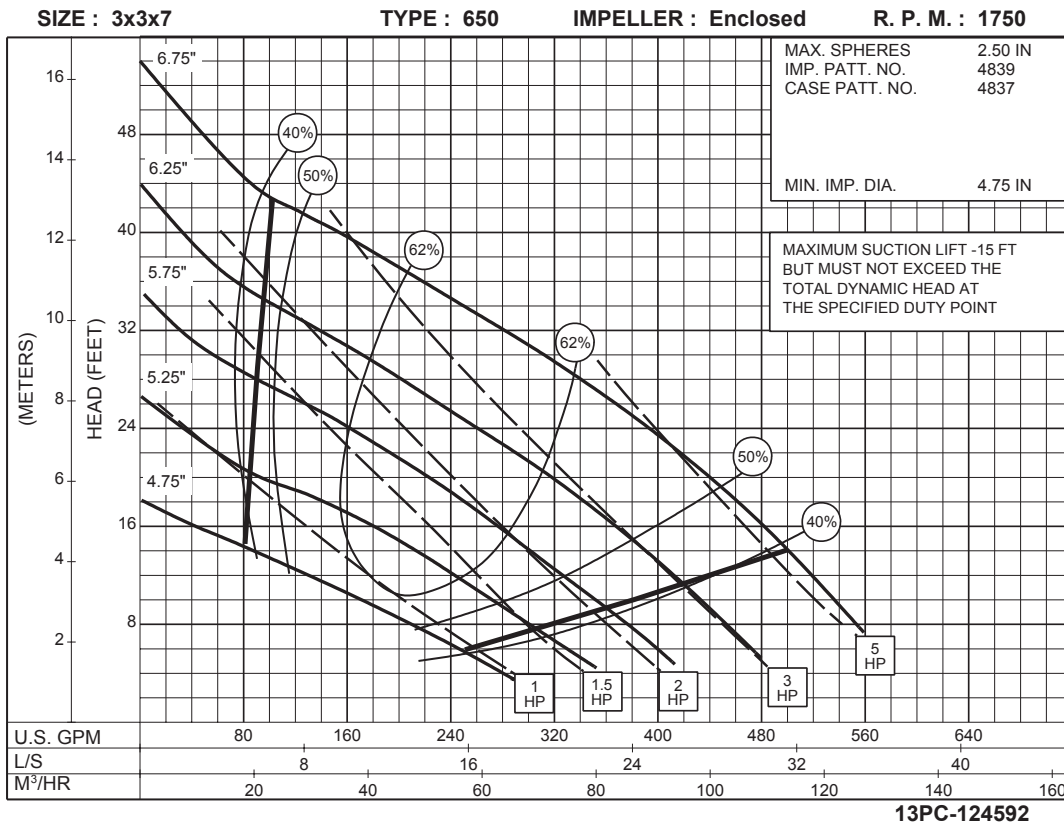

3 x 3 x 9 SERIES 650A

ENCLOSED IMPELLER

SIZE : 3x3x9 TYPE : 650 IMPELLER : Enclosed R. P. M. : 1750

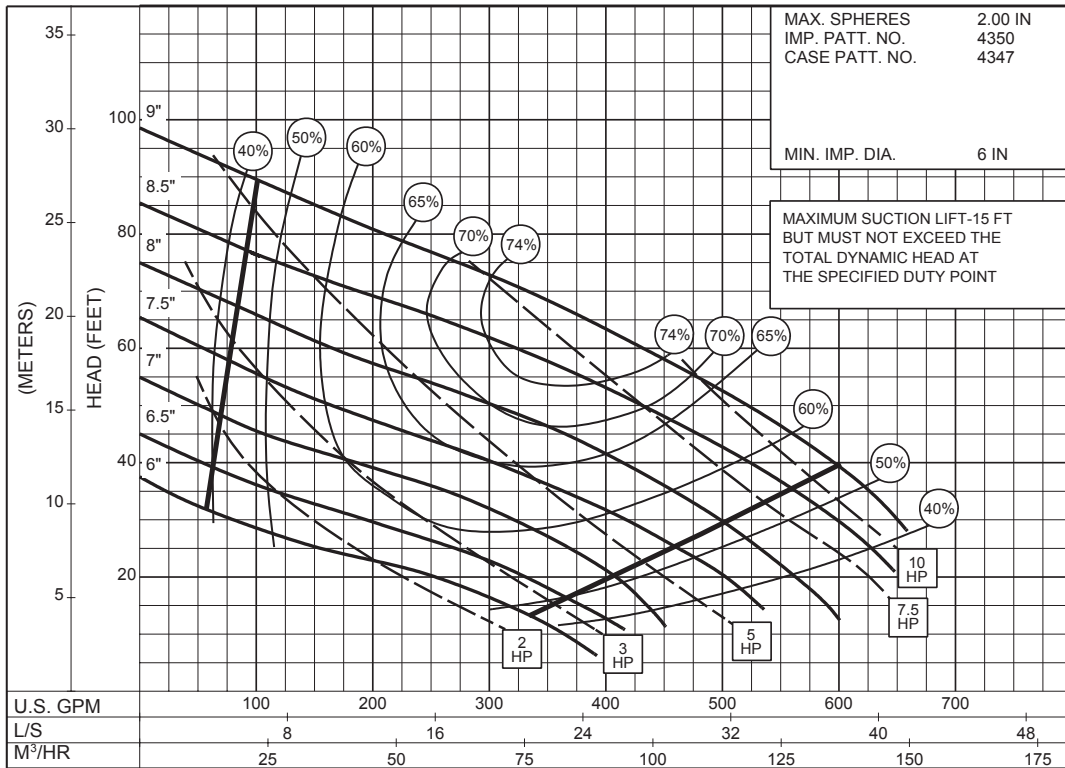

13PC-124590

1750
RPM

SIZE : 3x3x9 TYPE : 650 IMPELLER : Enclosed R. P. M. : 1150

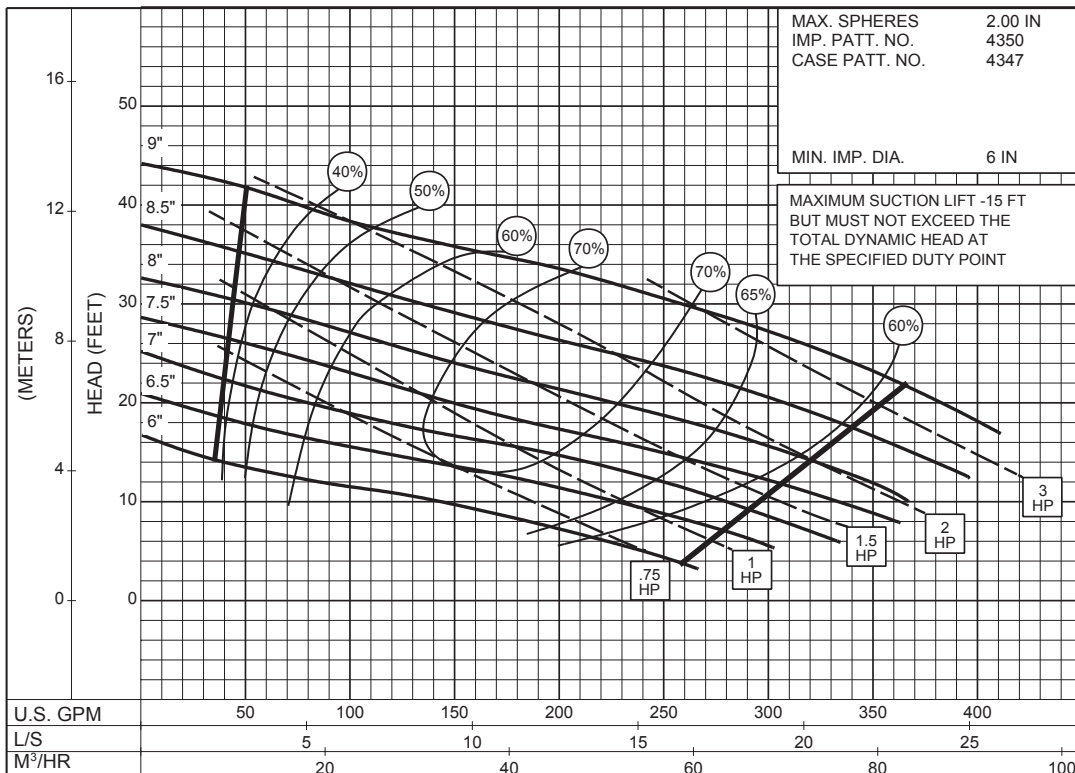

13PC-124589

1150
RPM

4 x 4 x 7 SERIES 650A

ENCLOSED IMPELLER

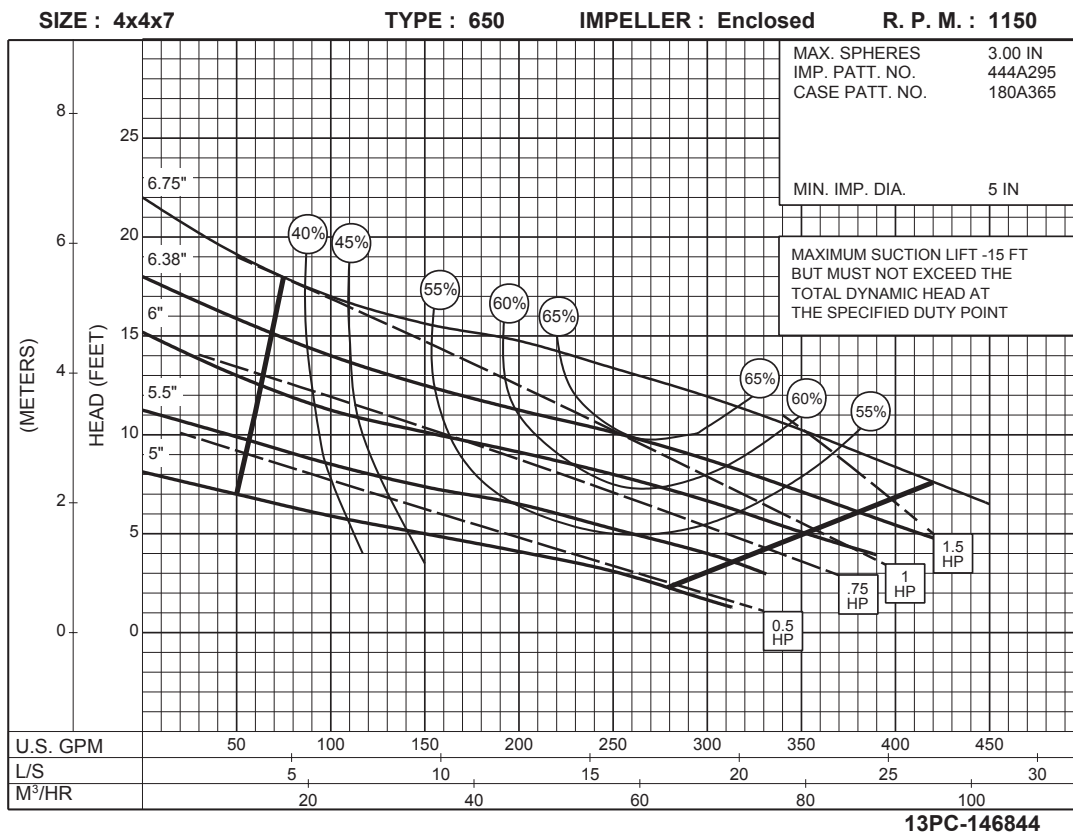
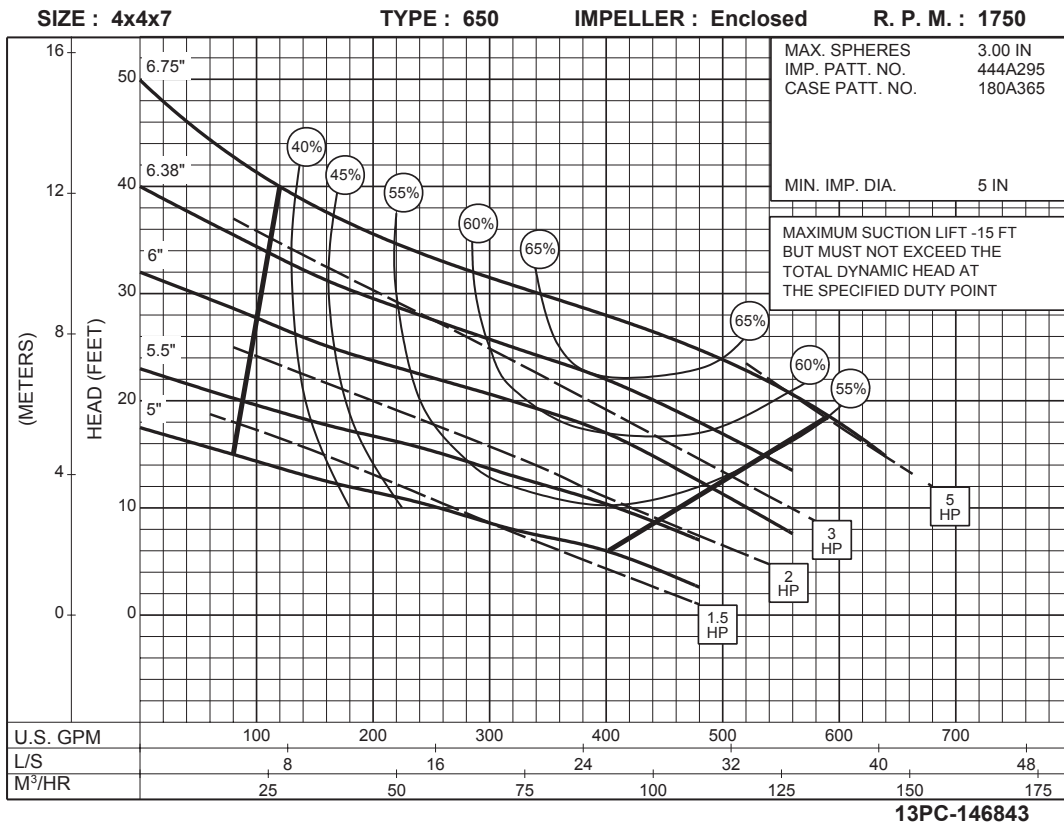

4 x 4 x 9A SERIES 650A

ENCLOSED IMPELLER

SIZE : 4x4x9A TYPE : 650 IMPELLER : Enclosed R. P. M. : 1750

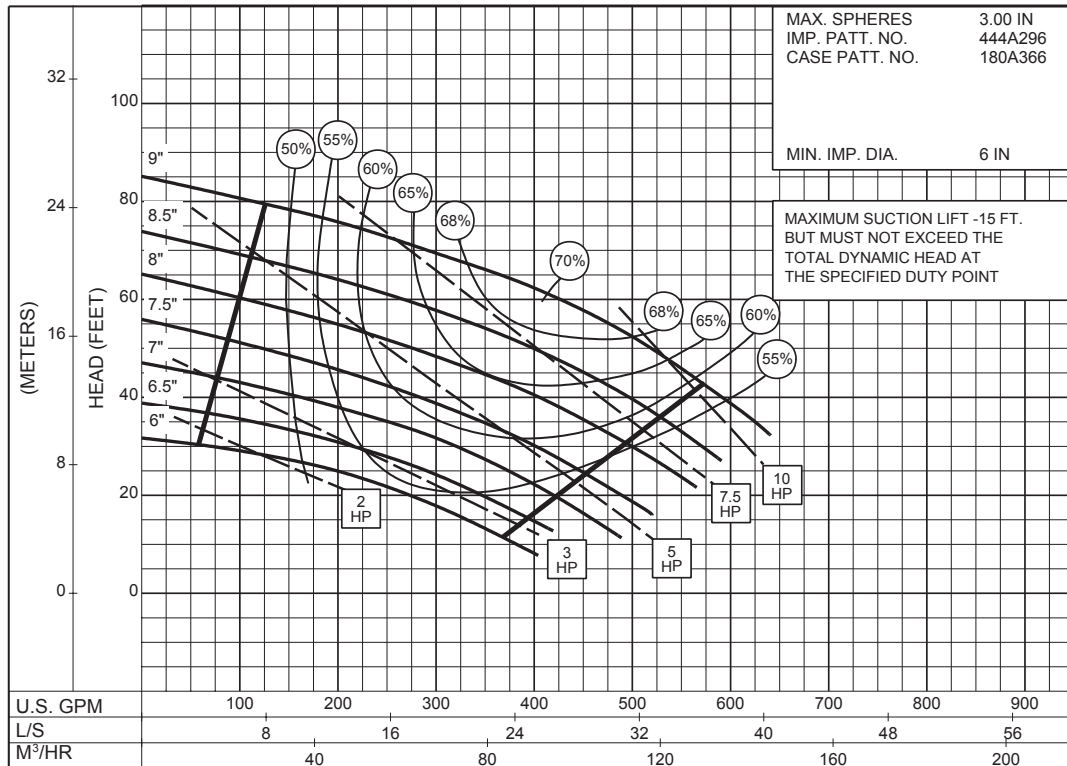

13PC-147001

1750
RPM

SIZE : 4x4x9A TYPE : 650 IMPELLER : Enclosed R. P. M. : 1150

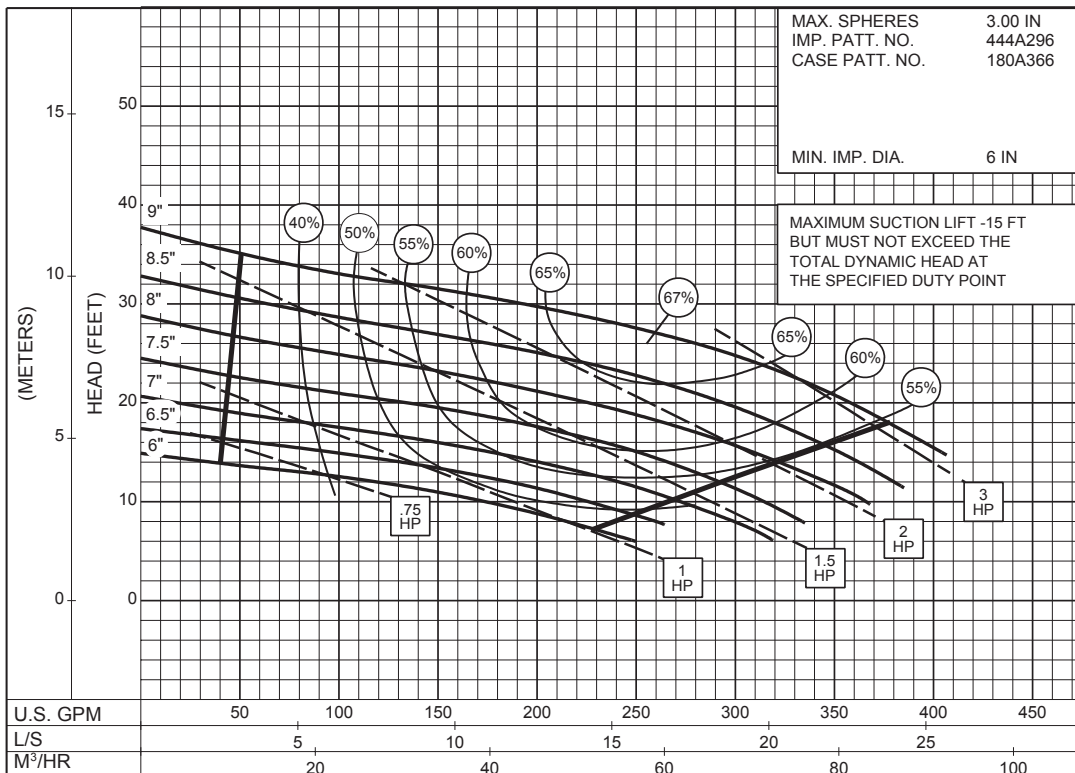

13PC-147002

1150
RPM

4 x 4 x 9B SERIES 650A

ENCLOSED IMPELLER

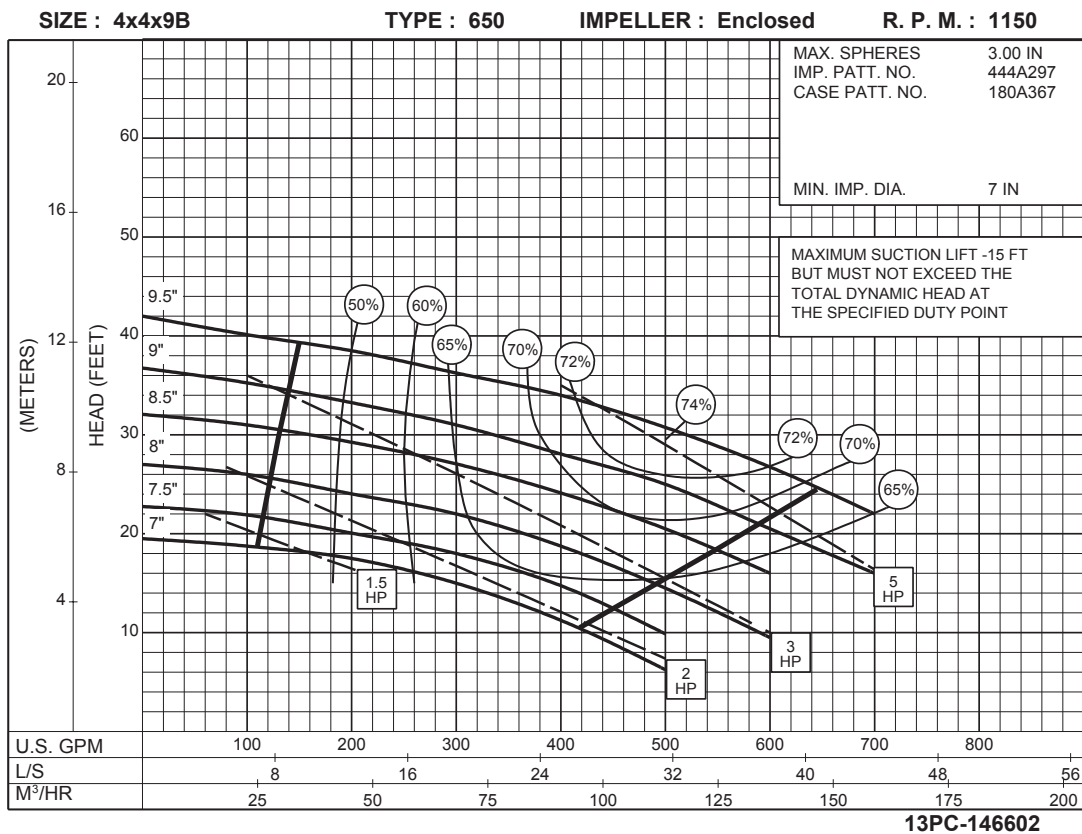
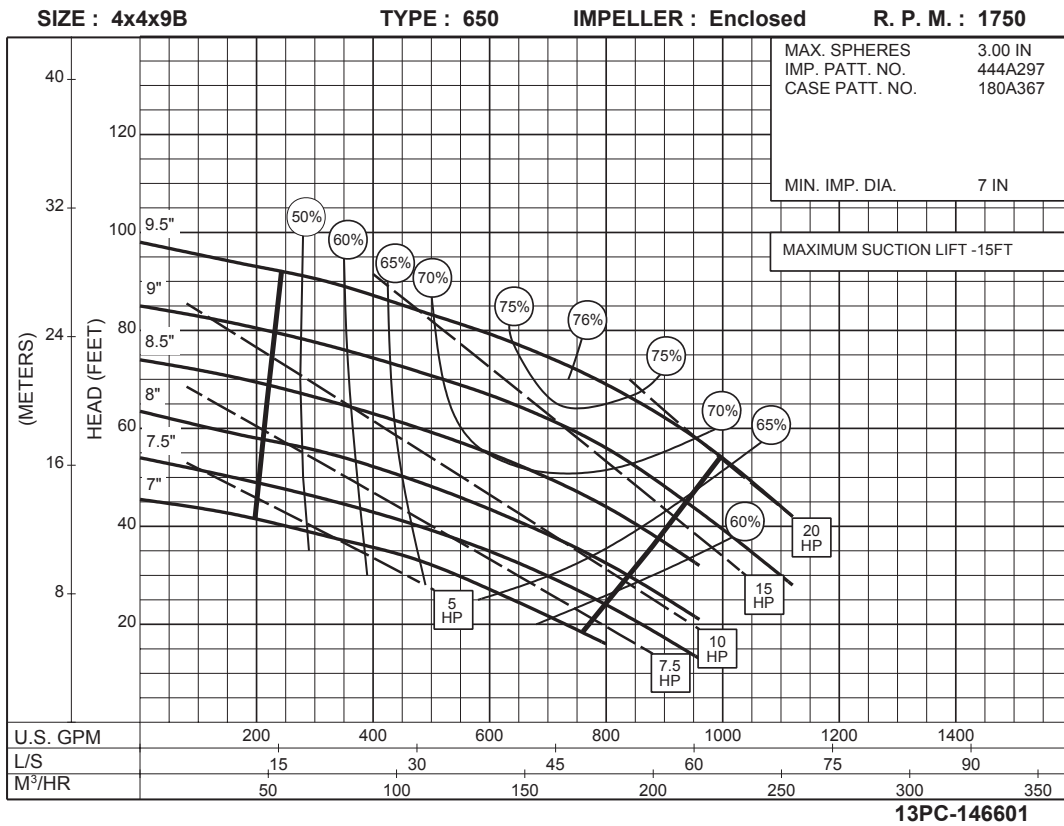

4 x 4 x 9B
SERIES 650A

ENCLOSED IMPELLER

SIZE : 4x4x9B TYPE : 650 IMPELLER : Enclosed R. P. M. : 875

MAX. SPHERES 3.00 IN
IMP. PATT. NO. 444A297
CASE PATT. NO. 180A367

MIN. IMP. DIA. 7 IN

MAXIMUM SUCTION LIFT - 15 FT
BUT MUST NOT EXCEED THE
TOTAL DYNAMIC HEAD AT
THE SPECIFIED DUTY POINT

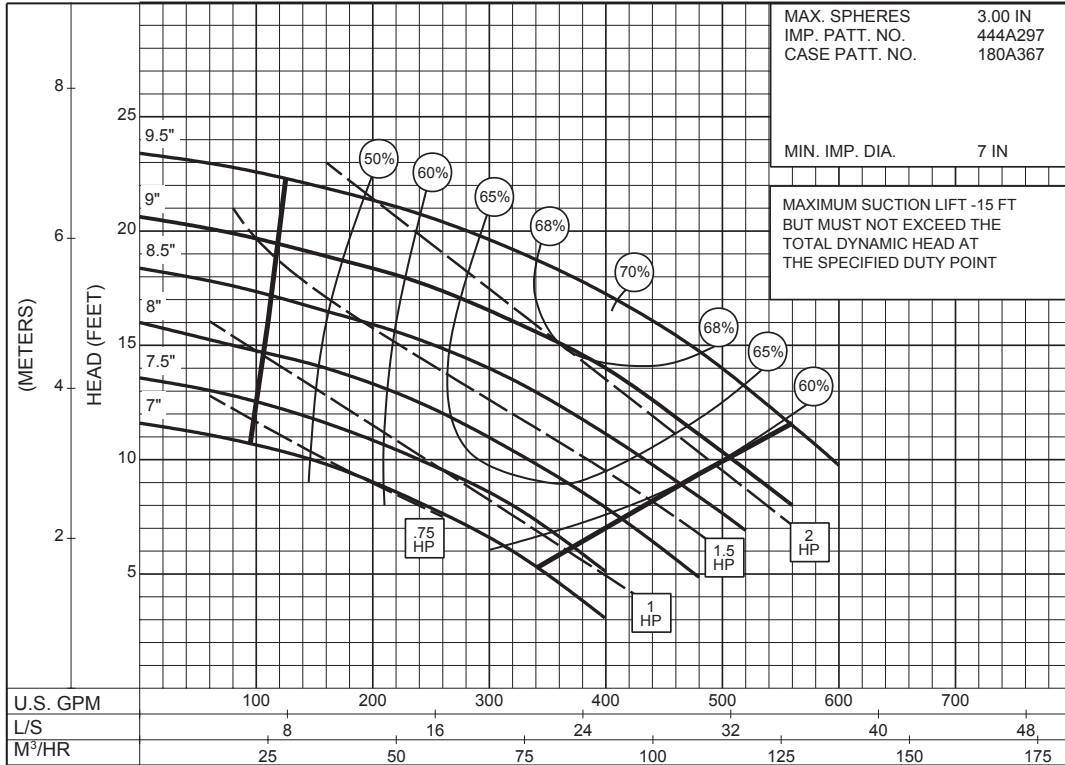

875
RPM

13PC-146603

4 x 4 x 12 SERIES 650A

ENCLOSED IMPELLER

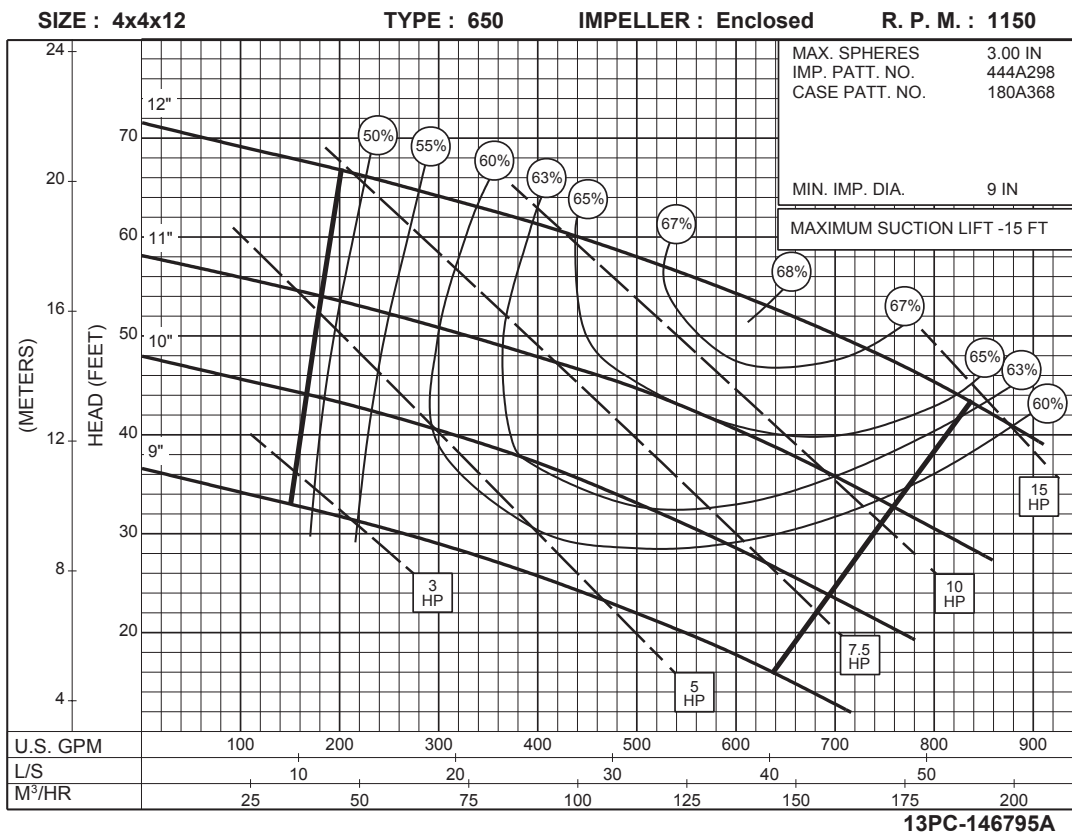
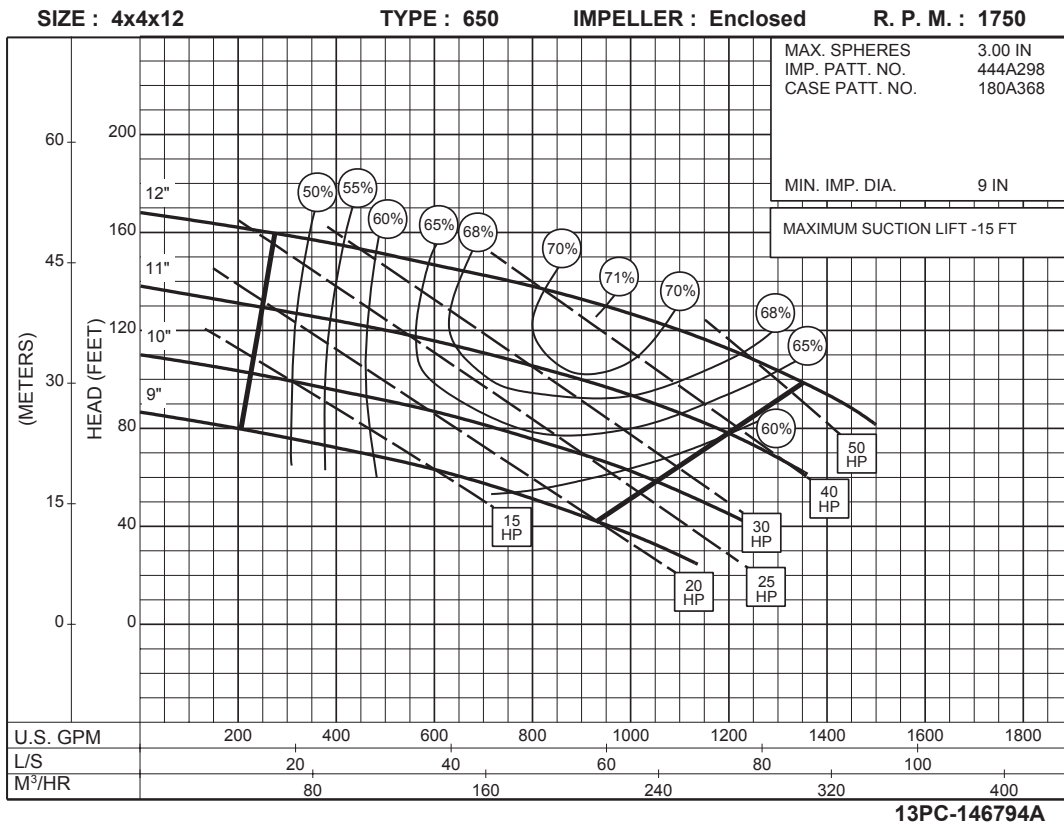

4 x 4 x 12 SERIES 650A

ENCLOSED IMPELLER

SIZE : 4x4x12 TYPE : 650 IMPELLER : Enclosed R. P. M. : 875

MAX. SPHERES 3.00 IN
IMP. PATT. NO. 444A298
CASE PATT. NO. 180A368

MIN. IMP. DIA. 9 IN

MAXIMUM SUCTION LIFT -15FT
BUT MUST NOT EXCEED THE
TOTAL DYNAMIC HEAD AT THE
SPECIFIED DUTY POINT.

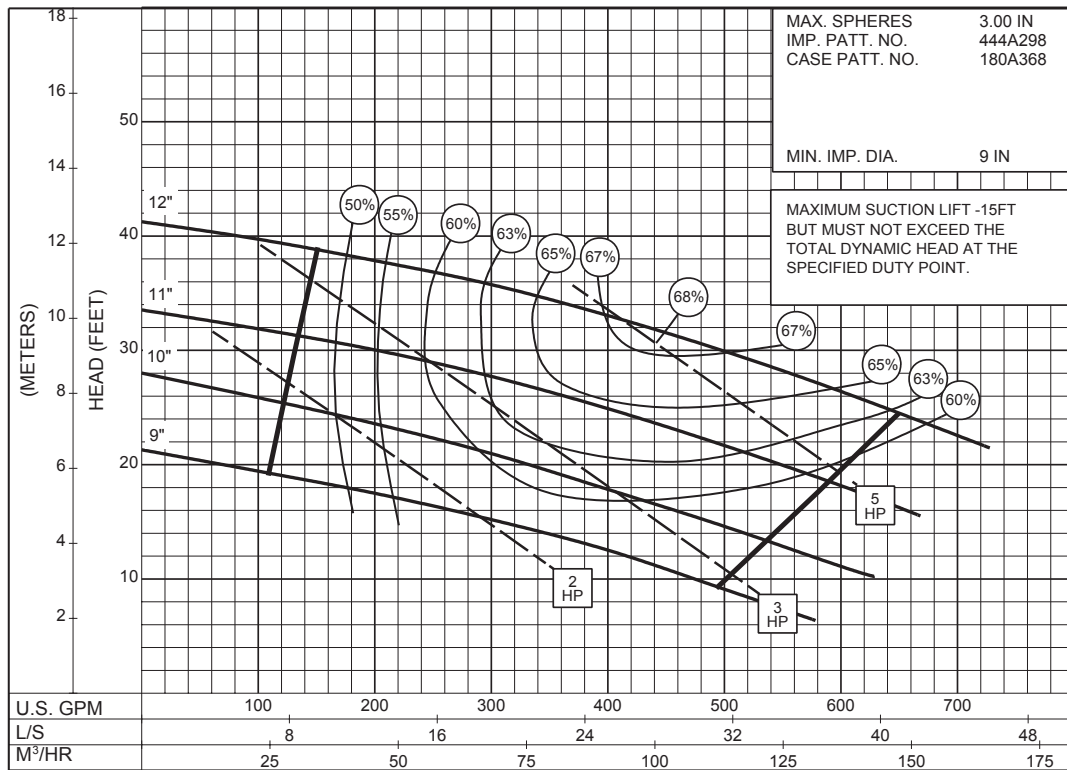

13PC-146796A

**875
RPM**

4 x 6 x 15 SERIES 650A

ENCLOSED IMPELLER

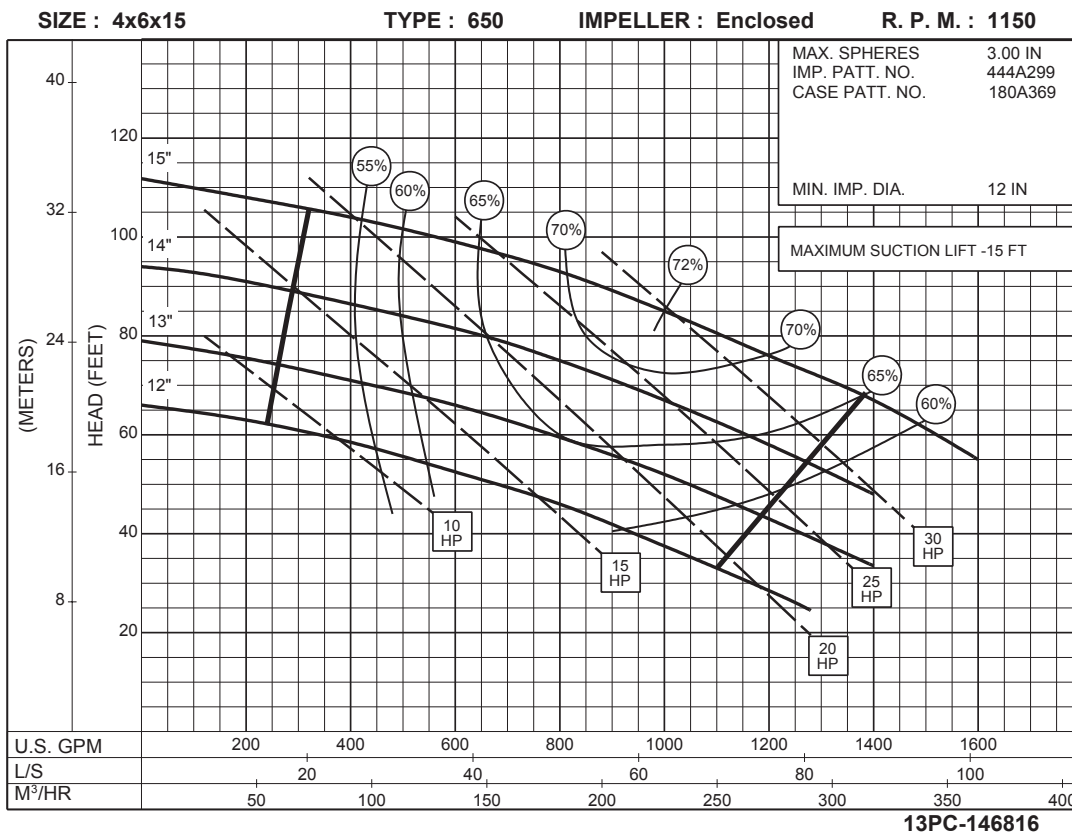
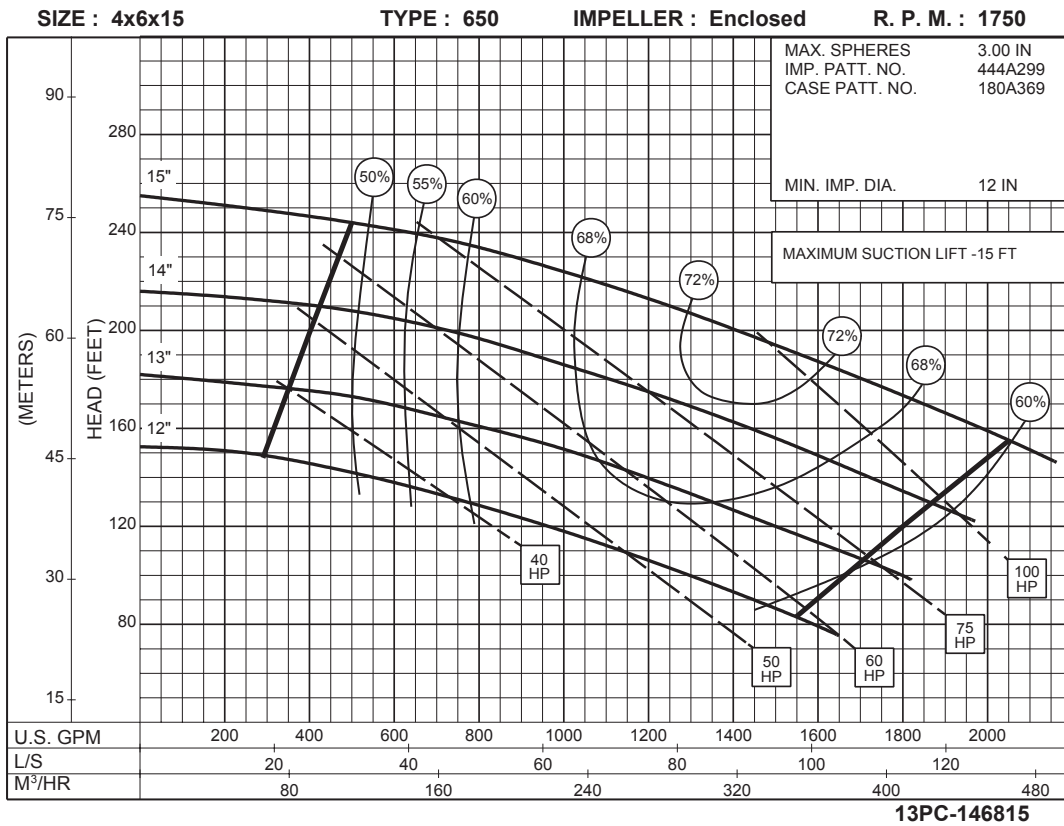

4 x 6 x 15
SERIES 650A

ENCLOSED IMPELLER

875
RPM

SIZE : 4x6x15 TYPE : 650 IMPELLER : Enclosed R. P. M. : 875

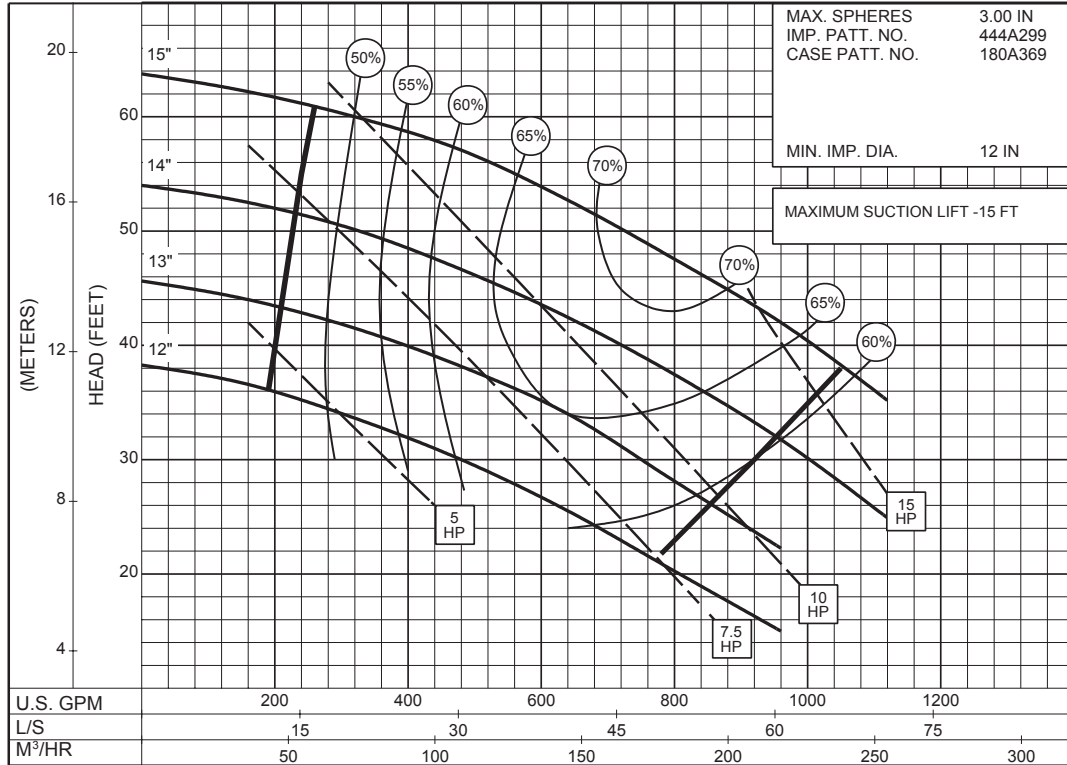

13PC-146817

700
RPM

SIZE : 4x6x15 TYPE : 650 IMPELLER : Enclosed R. P. M. : 700

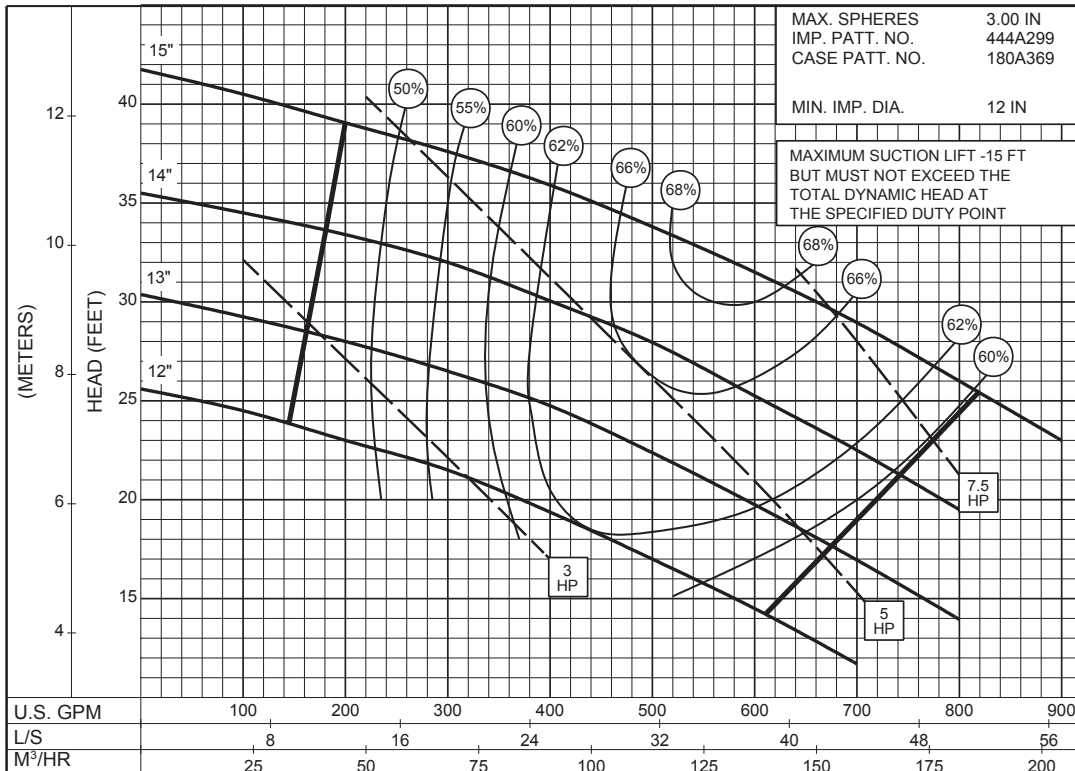

13PC-146818