

ENGINEERING DATA

MECHANICAL SEALS AND PACKING

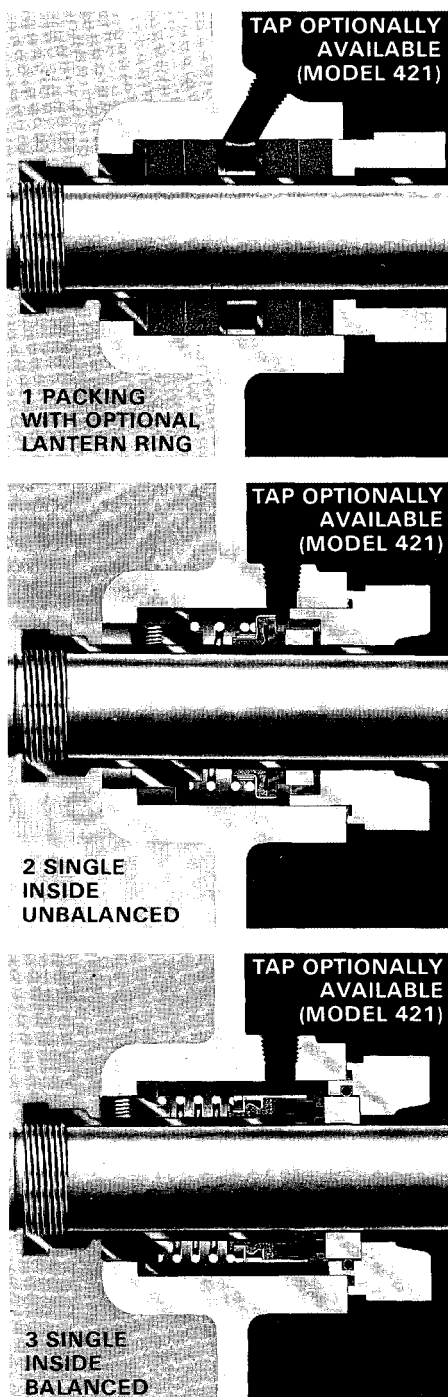

PRESSURES

TEMPERATURES

LIQUIDS

Standard packing on horizontal pumps and the standard mechanical seals on vertical pumps are suitable for most applications. Special sealing arrangements may however, be required due to higher pressure or temperature requirements and the nature of the liquid to be pumped. Factory option seals are of high quality and supplied by leading mechanical seal manufacturers. Various seal arrangements and types that better suit your specific needs are available. Seal faces are carbon vs. Ni-Resist on standard seals and carbon vs. Tungsten carbide on high temperature seals. Corrosion resistant alloy metal parts and Buna-N secondary sealing elements are provided. Various other metals are also available. Gland plates are cast iron and can be supplied in alternate materials. Recommendations and limitations are general. Specific selections can be offered only after rotating speeds, pressures, temperatures, type of equipment and liquid nature are known. The following illustrations describe the basic seal and packing options available. For options not shown refer to the factory. For quick reference for the type of seal best suited to your application, refer to the condensed information that heads each option. The following comments govern these recommendations:

PRESSURES — The pressures referred to are those found at the pump suction. Most seal manufacturers recommend a flushing arrangement from the discharge to the stuffing box where "below atmospheric pressure" is encountered. The 420 Series first stage stuffing box incorporates an internal bypass arrangement which permits flushing to the mechanical seal. External bypasses are available to both seal faces. An external bypass is standard on vertical pumps to the upper seal face.

TEMPERATURES — The temperature limitation of a mechanical seal is frequently determined by the shaft sealing material. The various elastomer "O" ring materials have varying temperature limits, depending upon the chemical and/or physical properties of the process fluid. Filled TEFLON†, shaft seal rings are available.

LIQUIDS — Due to varying degrees of resistance of various sealing compounds in different pumped liquids, the following mechanical seal sealing rings are available: BUNA-N, NEOPRENE, VITON, TEFLON† and other synthetic elastomers.

†DUPONT registered trademarks.

*NOTE: Hardened stainless steel (450 minimum brinell) shaft sleeves are available with this option and are required when the suction pressure is over 100 P.S.I.G. or when the temperature exceeds 225°F.

1 PACKING Standard on Model 421. Not available on 422 and 423. **PRESSURES** (suction): Below atmospheric up to 250* P.S.I.G. (Maximum pump limitation) A lantern ring is required on the first stage for suction lift applications.

TEMPERATURES: From minus 100°F. up to 275°F.* with high temperature packing, or 225°F. with standard packing.

LIQUIDS: All liquids that are compatible with graphited fiber packing. Other packings are available for special applications.

2 SINGLE — UNBALANCED Standard on Model 422 and 423. Optional on Model 421.

PRESSURES (suction): Below atmospheric up to 100 P.S.I.G.

TEMPERATURES: From minus 100°F. up to 275°F. with high temperature seals, or 225°F. with standard seals.

LIQUIDS: All liquids that are compatible with the seal materials of construction and with a specific gravity higher than .6.

3 SINGLE — BALANCED Optional on all Models.

PRESSURES (suction): Up to 250 P.S.I.G. (Max. pump limit)

TEMPERATURES: Minus 100°F. up to 275°F. with high temperature seals, or 225°F. with standard seals.

LIQUIDS: All that are compatible with the seal materials of construction and with a specific gravity of .6 or lower.

ENGINEERING DATA INTERCHANGEABILITY AND POWER SERIES

Aurora Models 421, 422 and 423 were designed for maximum interchangeability. Each model is available in 9 different sizes, offering a model and size

precisely fitted to the installation requirements. The 9 sizes are divided into 4 "power series." Within each power series, all parts are completely interchange-

able except for the impeller, casing, and case wearing rings for either right hand or left hand rotation. See the illustration below for all details.



**MODEL 423
MOTOR BRACKETS**

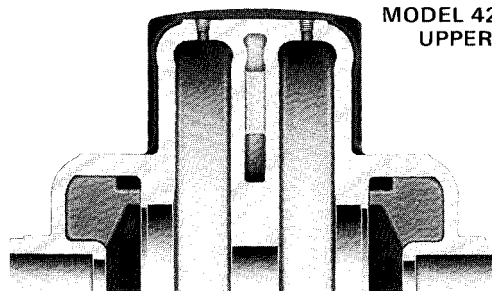

**MODEL 421, 422 & 423
UPPER CASINGS**

**MODEL 422 & 423
LOWER CASINGS**

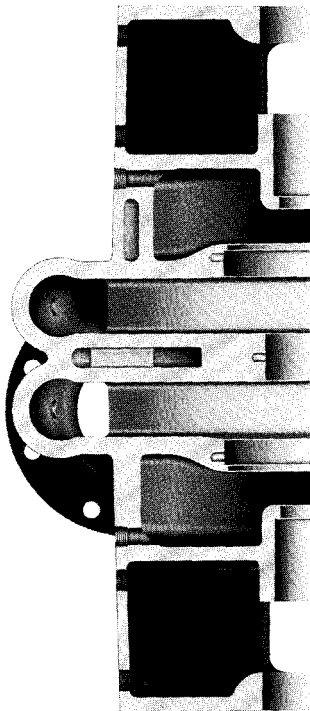

**MODEL 421, 422 & 423
SHAFT ASSEMBLIES (POWER SERIES)
COMPLETE ROTATING ASSEMBLY
CONSISTING OF A SHAFT, SHAFT
SLEEVES, GASKETS, KEYS,
INBOARD
BEARING
ASSEMBLY,
OUTBOARD
BEARING
ASSEMBLY
AND PACKING
OR MECHANICAL
SEAL ASSEMBLIES IS
INTERCHANGEABLE FOR
ALL PUMPS WITHIN
EACH POWER SERIES.**

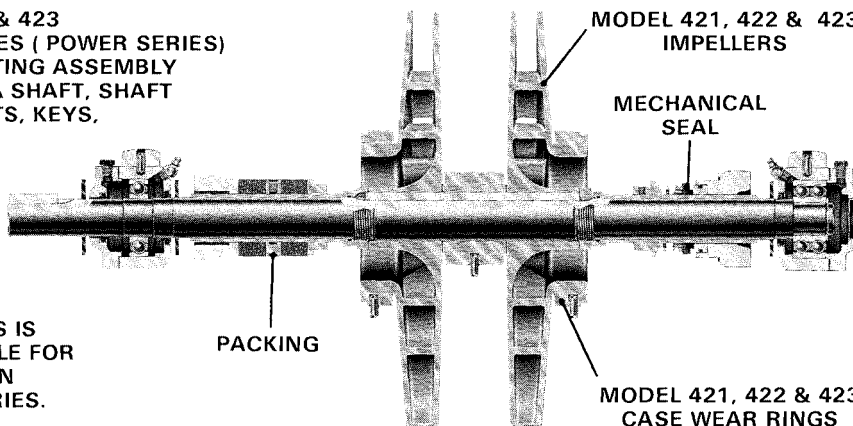

**MODEL 421, 422 & 423
IMPELLERS**

**MECHANICAL
SEAL**

PACKING

**MODEL 421, 422 & 423
CASE WEAR RINGS**

**MODEL 422 & 423
DRIP RIM BASES**



**MODEL 421
LOWER CASINGS**

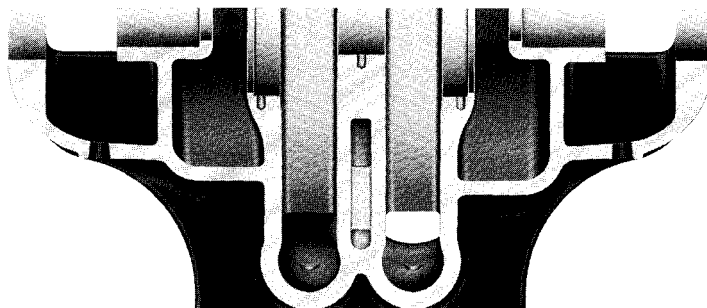

POWER SERIES	PUMP SIZE EXAMPLE: 3 x 4 x 14 (3-Discharge Dia.) (4-Suction Dia.) (14-Approx. Max. Impeller Dia.)				
2	3	4A	4	5A	5
2 x 2-1/2 x 12A	3 x 4 x 14A	5 x 5 x 12*	5 x 6 x 15*	6 x 6 x 12*	6 x 8 17A*
2 x 2-1/2 x 12B	3 x 4 x 14B				6 x 8 x 17B*
2-1/2 x 3 x 12A	4 x 5 x 15*	*Model 421 Pumps Only			

ENGINEERING DATA MATERIALS OF CONSTRUCTION

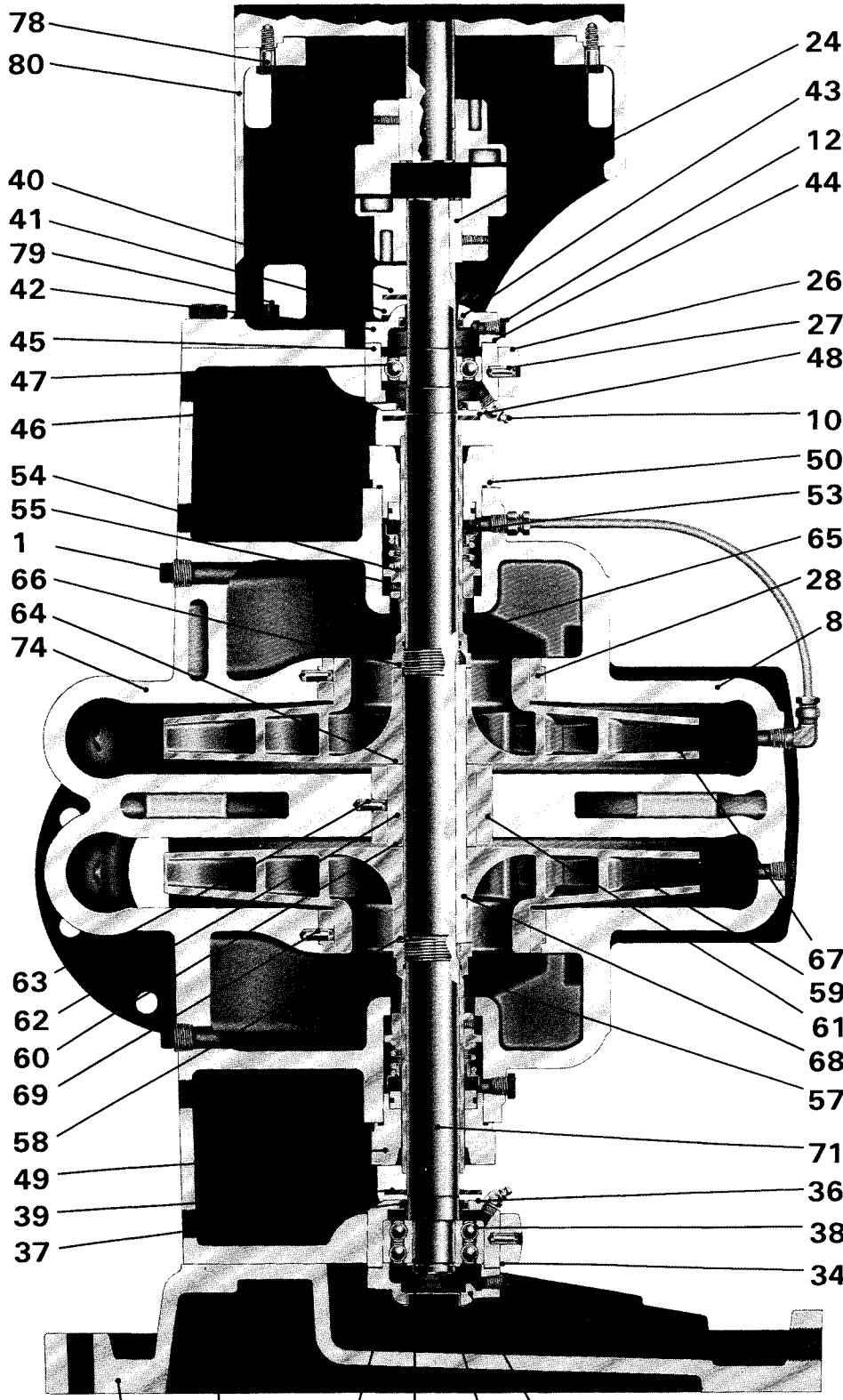

82 81 31 35 29 32 *PARTS NOT ILLUSTRATED.

Pc No	Descrip. (*Not Shown)	PUMP CONSTRUCTION			
		Bronze Fitted	All Bronze	All Iron	Stain. Steel
1	Plug	Mall. Iron A197	Bronze Wrought	Mall. Iron A197	Stain. Stl. AISI 316
2	*Plug	Mall. Iron A197	Bronze Wrought	Mall. Iron A197	Stain. Stl. AISI 316
6	*Capscrew	Steel SAE 2	Steel SAE 2	Steel SAE 2	Stain. Stl. AISI 316
7	*Capscrew	Steel SAE 2	Steel SAE 2	Steel SAE 2	Stain. Stl. AISI 316
8	Casing Half	Cast Iron A48	Bronze B62-4A	Cast Iron A48	Stain. Stl. ACI CF8M
9	*Gasket	Buna-N Treated Cellulose			
10	Gr. Ftg.	Steel Zerck			
12	Plug	Malleable Iron ASTM A197			
18	*Nut	Bronze Wrought	Steel SAE 2	Steel SAE 2	Stain. Stl. AISI 316
19	*Washer	Cad. Plt. Steel	Bronze Wrought	Cad. Plt. Steel	Stain. Stl. AISI 316
20	*Gland Clp.	Cad. Plt. Steel	Bronze Wrought	Cad. Plt. Steel	Stain. Stl. AISI 316
21	*Gland	Cast Iron A48	Bronze B62-4A	Cast Iron A48	Stain. Stl. ACI CF8M
22	*Swing Bolt	Cad. Plt. Steel	Sil. Brz. Wrought	Cad. Plt. Steel	Stain. Stl. AISI 316
23	*Packing	Graphited Fiber			
24	Key	Steel Wrought			
25	*Capscrew	Steel SAE 2	Bronze Wrought	Steel SAE 2	Stain. Stl. AISI 316
26	Bearing Cap	Cast Iron A48	Bronze B62-4A	Cast Iron A48	Stain. Stl. ACI CF8M
27	Pin	Cad. Plt. Steel	Stain. Stl. AISI 416	Cad. Plt. Steel	Stain. Stl. AISI 316
28	Case Ring	Bronze ASTM B62-4A	Cast Iron A48	Cast Iron A48	Stain. Stl. ACI CF8M
29	Protector	Steel Wrought			
31	Capscrew	Steel SAE 2			
32	Cart. Cap	Cast Iron ASTM A48			
34	Gasket	Buna-N Treated Cellulose			
35	Ret. Ring	Spring Steel			
36	Cartridge	Cast Iron ASTM A48			
37	Gr. Seal	Buna-N and Steel			
38	Bearing	Steel Commercial			
39-40	Slinger	Neoprene			
41	Capscrew	Steel SAE 2			
42	Cart. Cap	Cast Iron ASTM A48			
43	Gr. Seal	Buna-N and Steel			
44	Gasket	Buna-N Treated Cellulose			
45	Cartridge	Cast Iron ASTM A48			
46	Gr. Seal	Buna-N and Steel			
47	Bearing	Steel Commercial			
48	Slinger	Neoprene			
49	Gland	Cast Iron A48	Bronze B62-4A	Cast Iron A48	Stain. Stl. ACI CF8M
50	O-Ring	Buna-N			
52	*Lantern Ring	Bronze ASTM B62-4A	Cast Iron A48	Cast Iron A48	Stain. Stl. ACI CF8M
53	M. Seal	St. Stl. (1)	St. Stl. (2)	St. Stl. (1)	St. Stl. (2)
54	Collar	Bronze ASTM B62-4A	Cast Iron A48	Cast Iron A48	Stain. Stl. AISI 316
55	Setscrew	Stainless Steel AISI 316			
56	*Bushing	Bronze ASTM B62-4A	Cast Iron A48	Cast Iron A48	Stain. Stl. AISI 316
57	Sleeve	Bronze High Lead Tin	Stain. Stl. AISI 316	Stain. Stl. AISI 316	Stain. Stl. AISI 316
58	Gasket	Teflon DuPont			
59	Impeller	Bronze B119	Bronze B119	Cast Iron A48	Stain. Stl. ACI CF8M
60	Gasket	Teflon DuPont			
61	Bushing	Bronze ASTM B62-4A	Cast Iron A48	Cast Iron A48	Stain. Stl. ACI CF8M
62	Sleeve	Bronze ASTM B62-4A	Cast Iron A48	Cast Iron A48	Stain. Stl. ACI CF8M
63	Pin	Cad. Plt. Steel	Stain. Stl. AISI 416	Cad. Plt. Steel	Stain. Stl. AISI 316
64	Gasket	Teflon DuPont			
65	Sleeve	Bronze High Lead Tin	Stain. Stl. AISI 316	Stain. Stl. AISI 316	Stain. Stl. AISI 316
66	Gasket	Teflon DuPont			
67	Impeller	Bronze B584	Bronze B584	Cast Iron A48	Stain. Stl. ACI CF8M
68	Key	Stain. Stl. AISI 416	Stain. Stl. AISI 316	Stain. Stl. AISI 416	Stain. Stl. AISI 316
69	Pin	Cad. Plt. Steel	Stain. Stl. AISI 416	Cad. Plt. Steel	Stain. Stl. AISI 316
70	*Imp. Ring	Bronze B584	Cast Iron A48	Cast Iron A48	Stain. Stl. AISI 316
71	Shaft	Stl. AISI C1045	Stain. Stl. AISI 316	Stl. AISI C1045	Stain. Stl. AISI 316
72	*Pin	Cad. Plt. Steel	Stain. Stl. AISI 416	Cad. Plt. Steel	Stain. Stl. AISI 316
73	*Pin	Cad. Plt. Steel	Stain. Stl. AISI 416	Cad. Plt. Steel	Stain. Stl. AISI 316
74	Casing Half	Cast Iron A48	Bronze B62-4A	Cast Iron A48	Stain. Stl. ACI CF8M
75	*Drive Scr.	Steel Bronze Plated			
76	*Name Plt.	Stainless Steel AISI 303			
78-79	Capscrew	Steel SAE 2			
80	Bracket	Cast Iron ASTM A48			
81	Capscrew	Steel SAE 2			
82	Base	Cast Iron ASTM A48			

All material specifications are in accordance with ASTM unless otherwise noted. (1) B30P66171(JC) (2) XP661C1(JC).

ENGINEERING DATA

10 EXTERNAL PIPING can be provided when it is necessary to filter and regulate the flow of liquid to the stuffing box. With this option, piping is provided from the pump discharge to both stuffing boxes. If the pumped liquid is not suitable for sealing purposes, the standard internal passages can be plugged and external piping from a water seal unit can be provided directly to the stuffing box or seal chamber. Lantern

rings are required with this option on packed pumps.

11 MECHANICAL SEALS are available for special applications or hazardous service in single, balanced, and unbalanced designs. Packing with a lantern ring is available.

12 DOUBLE EXTENDED SHAFT option provides for dual drive appli-

cations such as an electric motor prime driver and stand-by diesel or internal combustion engine.

13 FLEXIBLE COUPLING is required between the pump and driver. It compensates for minor misalignment and reduces the transmission of vibration from the driver to the pump system. Clutch type couplings are available for the dual drive systems.

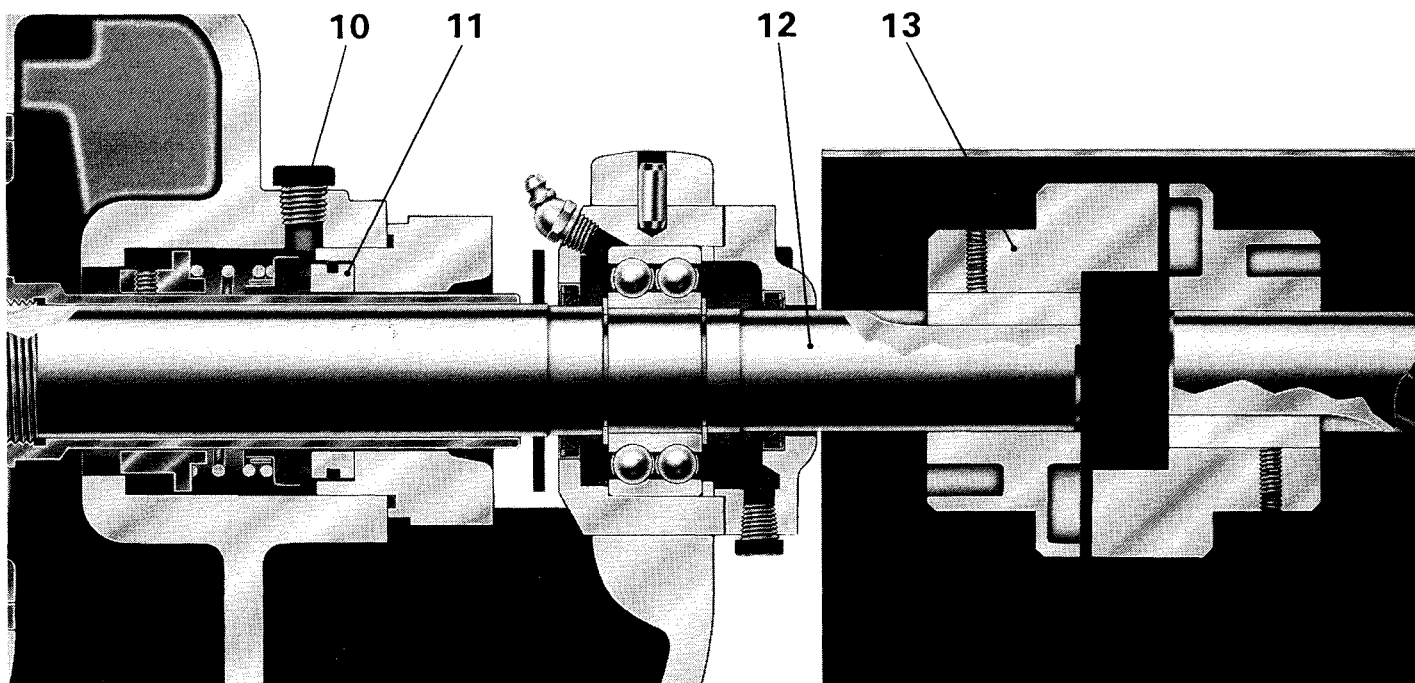

★**STANDARD PUMP:** Available in Bronze Fitted. Optional in All Bronze, All Iron, or Stainless Steel. Special materials are also available. **1. MECHANICAL SEALS.** **2. LANTERN RINGS:** Available for packed pumps only, provides lubrication under pressure to each stuffing box to extend packing life. An internal water seal passage provides the necessary lubricant from the pumped liquid. **3. FLUSHING LINES.** **4. IMPELLER WEARING RINGS:** Prevent rotational wear from occurring on the impeller and are easily replaced. The rings are press locked on the impeller. **5. CASE WEARING RINGS:** Available in 316 Stainless Steel for longer life. **6. SHAFT SLEEVES:** Minimum 450 Brinell Hardened 440C Stainless Steel is recommended for abrasive applications on packed pumps only. Pumps with mechanical seals are available with 316 Stainless Steel sleeves. **7. SHAFT MATERIAL:**

Standard pumps do not require alloy shafts as Teflon sealed shaft sleeves protect the shaft from corrosion. On severe applications 316 Stainless Steel shafting is available. Alloy shaft is recommended when inside balanced seals are specified. **8. DOUBLE EXTENDED SHAFT.** **9. VERTICAL PUMPS. OIL LUBRICATION:** Recommended for special applications such as remote installations, etc. Available only in Model 421. **11. 250 PSI FLANGES:** Suction and Discharge flanges machined to ASA flat face specifications. Special surface finishes such as raised face are available. **12. PETCOCK:** Vents air manually from the upper casing during initial start up. **13. VENT TAPS:** Oversize taps are available in either/or the upper casing or suction chambers. **14. BASES:** Available in cast iron with drip rim, formed steel or structural steel. **15. ABRASIVE SEPARATORS:** Available with option

3 to prevent entrained abrasives from entering the stuffing boxes via the recirculation or water seal liquid. **16. ORIFICE BY-PASS:** Regulates a predetermined flow of liquid to the stuffing boxes where this is desired. **17. GLAND EYEBOLTS AND NUTS:** For corrosive applications. Made of 316 Stainless Steel. **18. BRONZE PACKING GLANDS:** For corrosive duty. **19. ENGINEERING TESTS:** Several tests can be provided. (A) Certified Performance Test; (B) Certified Witness Performance Test; (C) Hydrostatic Test Submittal; (D) Vibration Test Submittal; (E) NPSH Test; (F) Witness NPSH Test. **20. COUPLING GUARD.** **23. DOUBLE ROW INBOARD BEARING:** Recommended for severe service such as direct drive with internal combustion engines. **ADDITIONAL MODIFICATIONS** are also available.

ENGINEERING DATA

SHAFT DEFLECTION AND BEARING LIFE

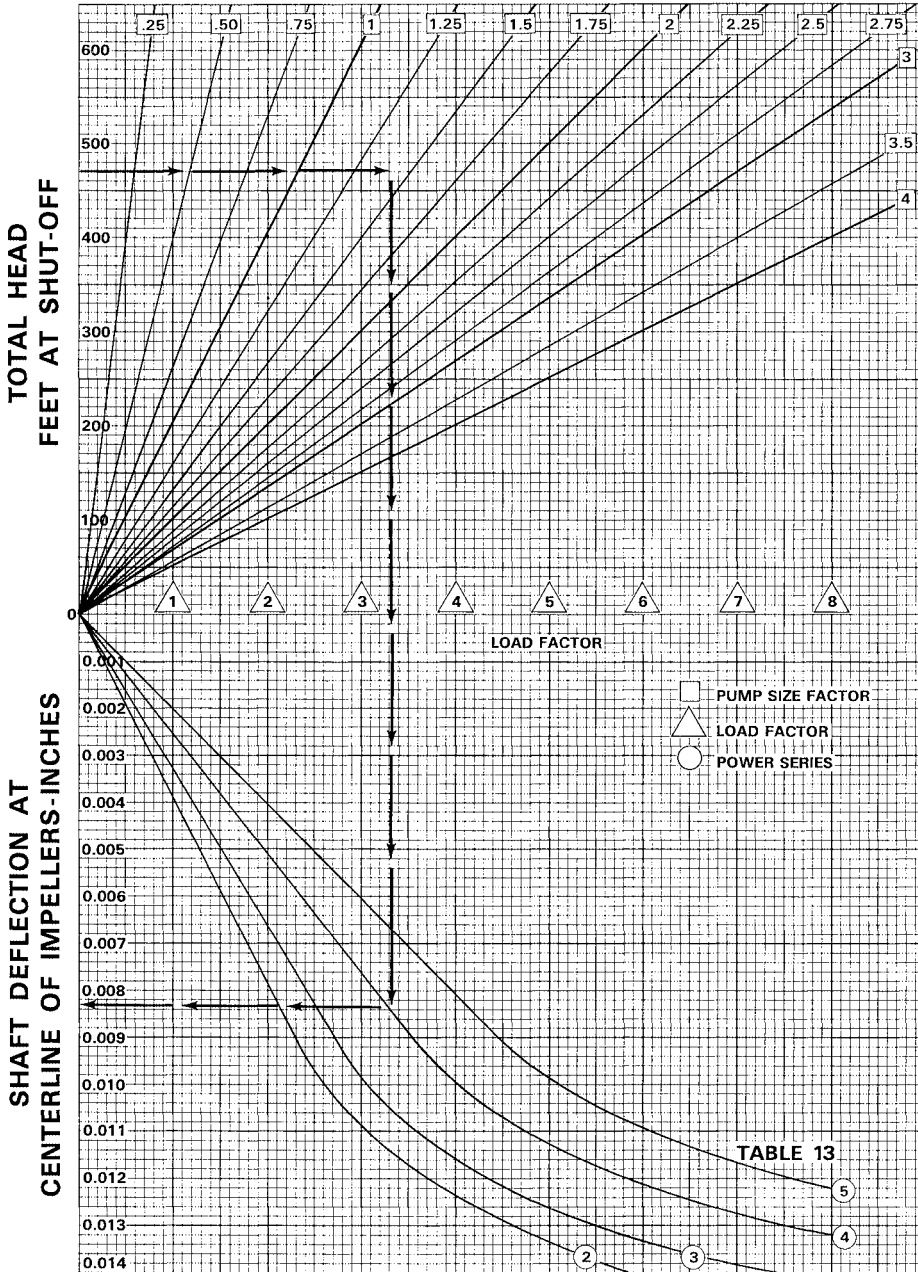
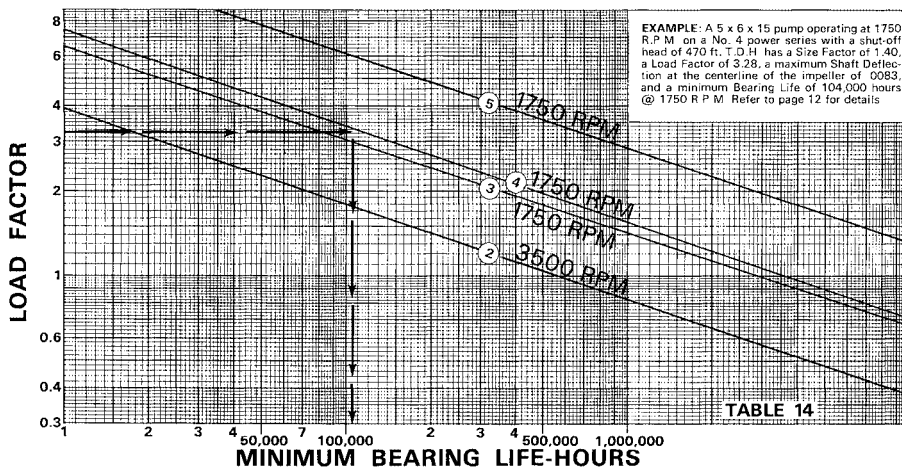

TABLE 13



EXAMPLE: A 5 x 6 x 15 pump operating at 1750 R.P.M. on a No. 4 power series with a shut-off head of 470 ft. T.D.H. has a Size Factor of 1.40, a Load Factor of 3.28, a maximum Shaft Deflection at the centerline of the impeller of .0083, and a minimum Bearing Life of 104,000 hours @ 1750 R.P.M. Refer to page 12 for details.

TABLE 14

QUIET PUMP operation is always desirable and sometimes essential. One of the most important factors for noise control in a pumping installation is the correct selection of a pumping unit for the system. To insure that the pump will run quietly, it should be selected so that it will operate as close as possible to the best efficiency point. At this point the hydraulic shock within the pump is at a minimum since the flow angle of the fluid from the tip of the impeller is correct for the casing design. Every pump is designed for the best efficiency point and operation at any other point on the characteristic curves is a compromise. The amount of turbulence on either side of the best efficiency point increases as the point of operation is moved along the curve from the maximum efficiency. Therefore, the greater the turbulence, the greater the noise generated. Hydraulic shock is also a factor if the periphery of the impeller passes too close to the cutwater. If the ratio of the impeller diameter to the cutwater diameter in centrifugal pumps is greater than 0.92, the pump is likely to be hydraulically noisy. In such instances the hydraulic pulses are actually differential pressures that occur when the impeller vanes pass the cutwater. Cutwater ratios of 0.9 to 9.5 are typical; however, significantly lower noise levels are achieved in pumps designed with a ratio of 0.7 to 0.75. Although there is an optimum gap for pump efficiency, increases of only 3%-5% may be realized by using the optimum. A cutwater ratio of 0.85 is commonly specified by practicing engineers, thereby realizing a minimum reduction in pump efficiency with a mean reduction in noise level. Table 9 offers recommended quiet impeller diameter at 85% cutwater ratio. See Aurora Pump for details.

The charts reflect the *worst possible* conditions at pump shut-off. The effect from the impeller, shaft sleeves, wearing rings and packing will *reduce* the amount of deflection.

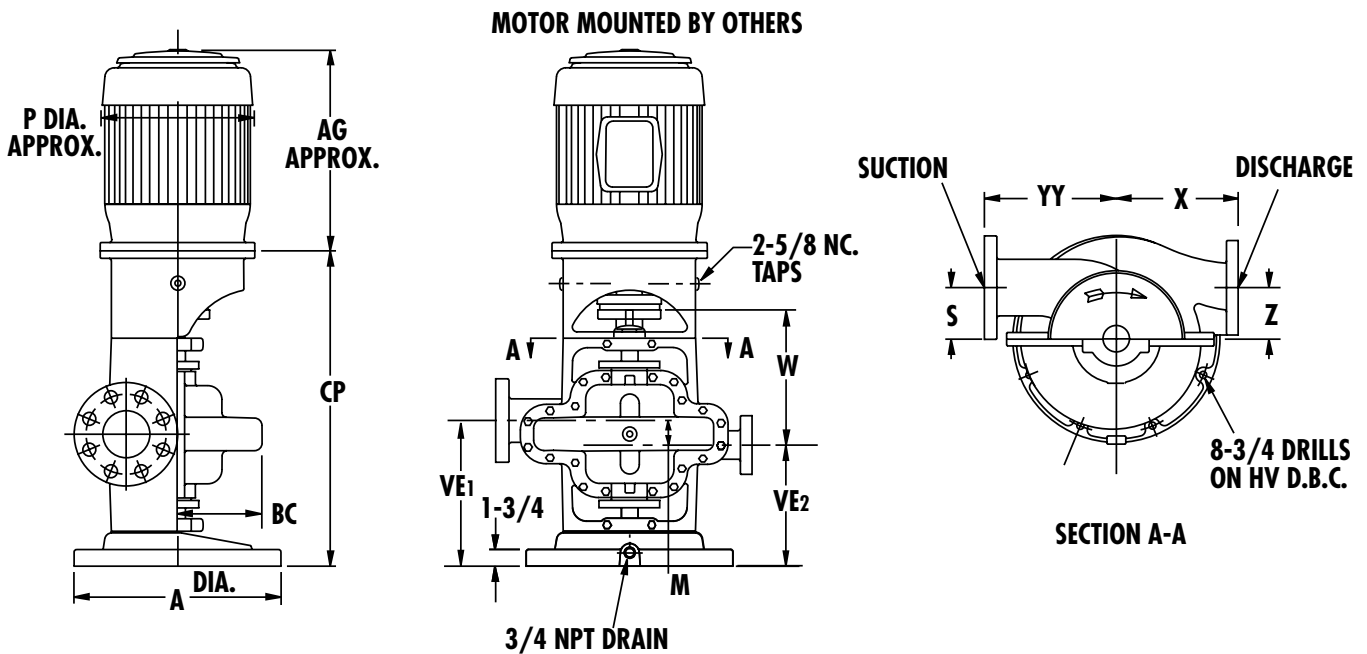

NOTES

1. All dimensions are in inches (mm).
2. Dimensions may vary $\pm 3/8"$ (10).
3. Not for construction purposes unless certified.
4. Coupling gap may vary $1/8"$ to $1"$.
5. Conduit box is shown in approximate location. Dimensions are not specified as they vary with each motor manufacturer.
6. Discharge and suction flanges - American Standard flat face.

STD. 125# SUCTION FLANGES & 250# DISCHARGE FLANGES	OPT. 250# FLANGES
--	-------------------

RIGHT HAND PUMP DIMENSIONS

PUMP SIZE			POWER SERIES	A	M	S	W	Z	BC	CP		HV	VE ₁	VE ₂	X	YY
DISCH	SUCTION	CASE BORE								143HP-256HP	284HPH 404HP					
2	2-1/2	12	2	18 (457)	4-3/4 (121)	4 (102)	15-3/4 (400)	5-1/2 (140)	10 (254)	32-1/8 (816)	34 (864)	16-1/4 (413)	17-5/8 (448)	12-7/8 (327)	10 (254)	10-1/4 (260)
2-1/2	3	12	2	18 (457)	5-3/8 (137)	4 (102)	15-7/8 (403)	5-1/2 (140)	10 (254)	32-1/8 (816)	34 (864)	16-1/4 (413)	18-1/8 (460)	12-3/4 (324)	11 (279)	11 (279)
3	4	14	3	22 (559)	6-3/4 (171)	4-1/2 (114)	18-3/4 (476)	6 (152)	11 (279)	37-3/8 (949)	39-3/4 (1010)	20 (508)	21-1/2 (546)	14-3/4 (375)	12 (305)	12-3/8 (314)

Frame	143 HP	145 HP	182 HP	184 HP	213 HP	215 HP	254 HP	256 HP	284 HP	286 HP	324 HP	326 HP	364 HP	365 HP	404 HP
P	8	8	10	10	11	11	13	13	16	16	18	18	20	20	22
AG	11	12	13	14	16	18	20	22	23	24	25	27	32	32	35

Date **March 2004**

Supersedes Section 420 Page 206

Dated November 2001

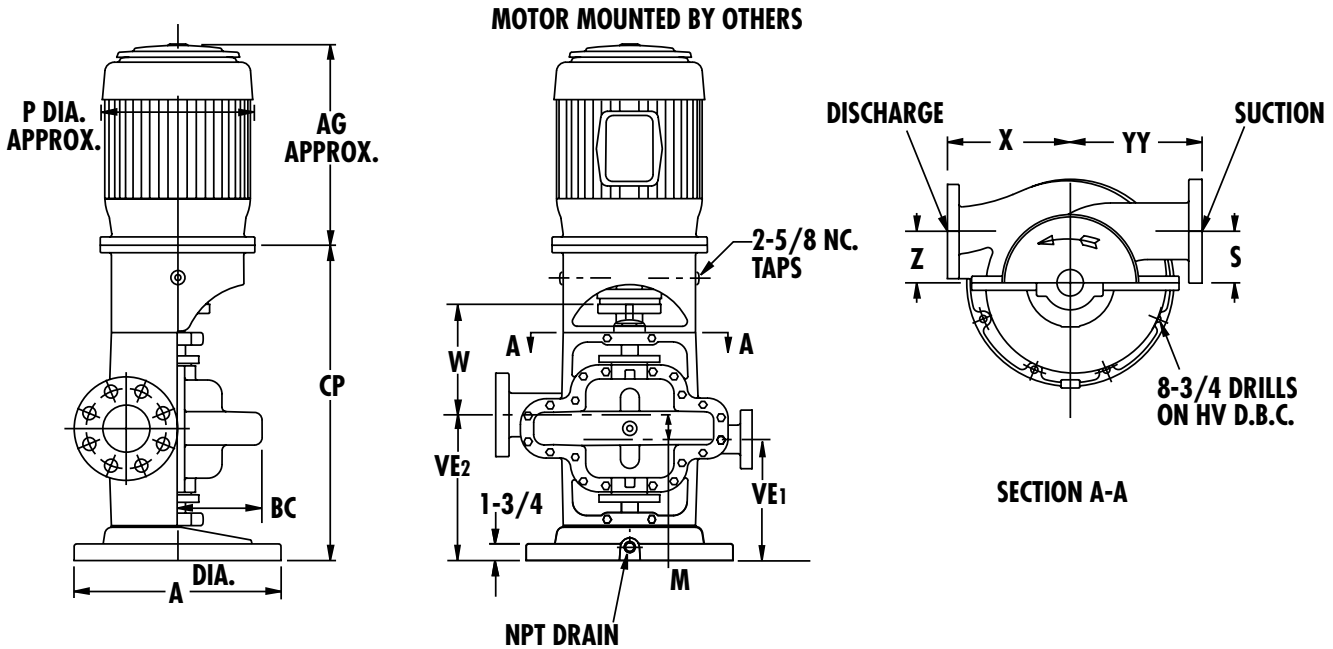

NOTES

1. All dimensions are in inches (mm).
2. Dimensions may vary $\pm 3/8"$ (10).
3. Not for construction purposes unless certified.
4. Coupling gap may vary $1/8"$ to $1"$.
5. Conduit box is shown in approximate location. Dimensions are not specified as they vary with each motor manufacturer.
6. Discharge and suction flanges - American Standard flat face.

STD. 125# SUCTION FLANGES & 250# DISCHARGE FLANGES	OPT. 250# FLANGES
--	-------------------

LEFT HAND PUMP DIMENSIONS

PUMP SIZE			POWER SERIES	A	M	S	W	Z	BC	CP		HV	VE ₁	VE ₂	X	YY
DISCH	SUCTION	CASE BORE								143HP-256HP	284HPH-404HP					
2	2-1/2	12	2	18 (457)	4-3/4 (121)	4 (102)	13-1/4 (349)	5-1/2 (140)	10 (254)	32-1/8 (816)	34 (864)	16-1/4 (413)	10-5/8 (270)	15-3/8 (391)	10 (254)	10-1/4 (260)
2-1/2	3	12	2	18 (457)	5-3/8 (137)	4 (102)	13-1/8 (340)	5-1/2 (140)	10 (254)	32-1/8 (816)	34 (864)	16-1/4 (413)	10-1/8 (257)	15-1/2 (394)	11 (279)	11 (279)
3	4	14	3	22 (559)	6-3/4 (171)	4-1/2 (114)	15-1/4 (387)	6 (152)	11 (279)	37-3/8 (949)	39-3/4 (1010)	20 (508)	11-1/2 (292)	18-1/4 (464)	12 (305)	12-3/8 (314)

Frame	143 HP	145 HP	182 HP	184 HP	213 HP	215 HP	254 HP	256 HP	284 HPH	286 HPH	324 HP	326 HP	364 HP	365 HP	404 HP
P	8	8	10	10	11	11	13	13	16	16	18	18	20	20	22
AG	11	12	13	14	16	18	20	22	23	24	25	27	32	32	35

AURORA TYPE AJ SELECTION CHART 1150 R.P.M. ENCLOSED IMPELLER

