

410 SERIES ENGINEERING DATA MECHANICAL SEALS AND PACKING

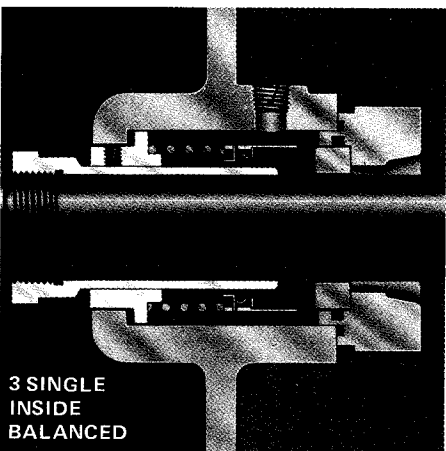
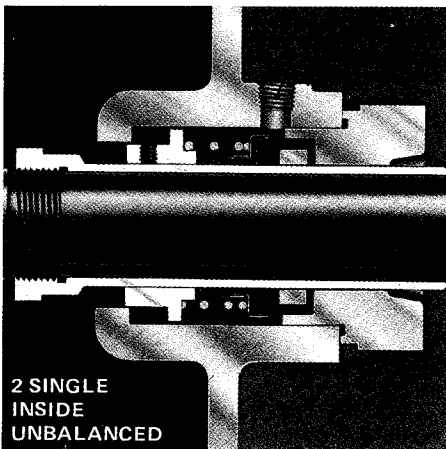
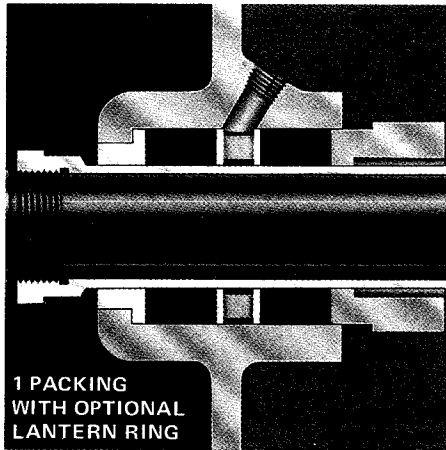

Standard packing on horizontal pumps and the standard mechanical seals on vertical pumps are suitable for most applications. Special sealing arrangements may however, be required due to higher pressure or temperature requirements and the nature of the liquid to be pumped. Factory option seals are of high quality and supplied by leading mechanical seal manufacturers. Various seal arrangements and types that better suit your specific needs are available. Seal faces are carbon vs. Ni-Resist on standard seals and carbon vs. Tungsten carbide on high temperature seals. Corrosion resistant alloy metal parts and Buna-N secondary sealing elements are provided. Various other metals are also available. Gland plates are cast iron and can be supplied in alternate materials. Recommendations and limitations are general. Specific selections can be offered only after rotating speeds, pressures, temperatures, type of equipment and liquid nature are known. The following illustrations describe the basic seal and packing options available. For options not shown refer to the factory. For quick reference for the type of seal best suited to your application, refer to the condensed information that heads each option. The following comments govern these recommendations:

1 PACKING Standard on Model 411. Not avail. on 412 & 413. **PRESSURES** (suction): Below atmospheric up to 250* P.S.I.G. (Maximum pump limitation) Lantern rings are required on suction lift applications.

TEMPERATURES: From minus 100°F. up to 275°F.* with high temperature packing, or 225°F. with standard packing.

LIQUIDS: All liquids that are compatible with braided fiber packing. Other packings available for special applications.

2 SINGLE — UNBALANCED Standard on Model 412 and 413. Optional Model 411.

PRESSURES (suction): Below atmospheric up to 100 P.S.I.G.

TEMPERATURES: From minus 100°F. up to 275°F. with high temperature seals, or 225°F. with standard seals.

LIQUIDS: All liquids that are compatible with the seal materials of construction and with a specific gravity higher than .6.

3 SINGLE — BALANCED Optional on all Models.

PRESSURES (suction): Up to 250 P.S.I.G. (Max. pump limit)

TEMPERATURES: Minus 100°F. up to 275°F. with high temperature seals, or 225°F. with standard seals.

LIQUIDS: All liquids that are compatible with the seal materials of construction. Required on liquids with a specific gravity of .6 or lower.

PRESSURES

TEMPERATURES

LIQUIDS

PRESSURES — The pressures referred to are those found at the pump suction. Most seal manufacturers recommend a flushing arrangement from the discharge to the stuffing box where "below atmospheric pressure" is encountered. The 410 Series stuffing boxes incorporate internal bypass arrangements which permit flushing to the mechanical seals. External bypasses are available to both seal faces. An external bypass is standard on vertical pumps to the upper seal face.

TEMPERATURES — The temperature limitation of a mechanical seal is frequently determined by the shaft sealing material. The various elastomer "O" ring materials have varying temperature limits, depending upon the chemical and/or physical properties of the process fluid. Filled TEFLON[†], shaft seal rings are available.

LIQUIDS — Due to varying degrees of resistance of various sealing compounds in different pumped liquids, the following mechanical seal sealing rings are available: BUNA-N, NEOPRENE, VITON, TEFLON[†] and other synthetic elastomers.

[†]DUPONT registered trademark.

*NOTE: Hardened stainless steel (450 minimum brinell) shaft sleeves are available with this option and are required when the suction pressure is over 100 P.S.I.G. or when the temperature exceeds 225°F.

410 SERIES ENGINEERING DATA INTERCHANGEABILITY AND POWER SERIES

Aurora Models 411, 412 and 413 were designed for maximum interchangeability. Each model is available in 34 different sizes, offering a model and

size precisely fitted to the installation requirements. The 34 sizes are divided into 7 "power series." Within each power series, all parts are completely

interchangeable except for the impeller, casing, and case wearing rings for either right hand or left hand rotation. See the illustration below for all details.

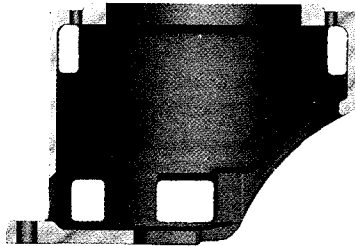

**MODEL 413
 MOTOR BRACKETS**

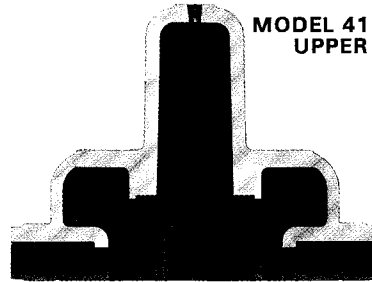

**MODEL 411, 412 & 413
 UPPER CASINGS**

**MODEL 412 & 413
 LOWER CASINGS**

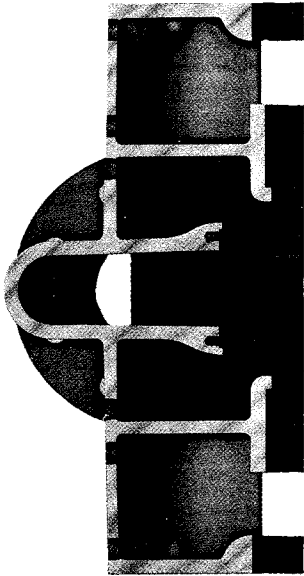

**MODEL 411, 412 & 413
 SHAFT ASSEMBLIES (POWER SERIES)
 COMPLETE ROTATING ASSEMBLY
 CONSISTING OF A SHAFT, SHAFT
 SLEEVES, GASKETS, KEYS,
 INBOARD BEARING
 ASSEMBLY,
 OUTBOARD
 BEARING
 ASSEMBLY
 AND PACKING
 OR MECHANICAL SEAL
 ASSEMBLIES ARE INTERCHANGEABLE FOR
 ALL PUMPS WITHIN EACH POWER SERIES.**

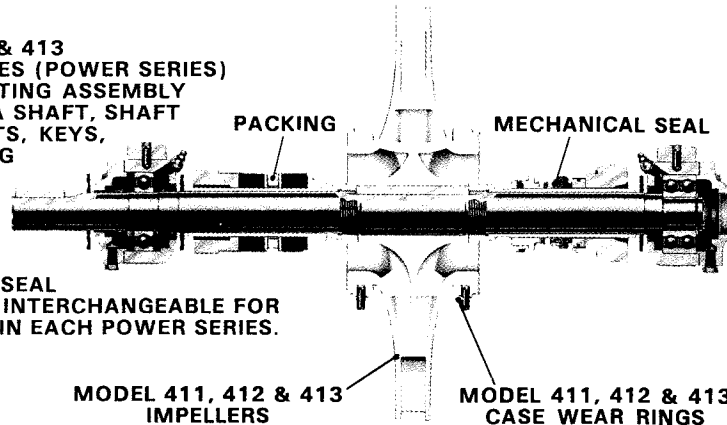

**MODEL 411, 412 & 413
 IMPELLERS**

**MODEL 411, 412 & 413
 CASE WEAR RINGS**

**MODEL 412 & 413
 DRIP RIM BASES**



**MODEL 411
 LOWER CASINGS**

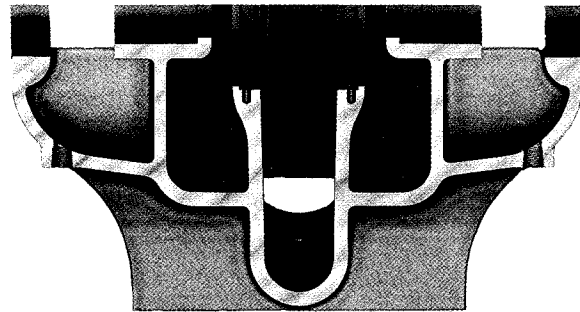

POWER SERIES

Pump Size Example: 3 x 4 x 14 (3-Discharge Dia.) (4-Suction Dia.) (14-Approx. Max. Impeller Dia.).

1	2	3	4	5	6B	7*		
2 x 2½ x 9	2½ x 3 x 10B	4 x 5 x 11A	—	5 x 6 x 17	6 x 8 x 15	8 x 10 x 12	10 x 12 x 12B	12 x 14 x 15B
2 x 2½ x 10	2½ x 3 x 12	4 x 5 x 11C	4 x 6 x 18B	6 x 8 x 11	6 x 8 x 18A	—	10 x 12 x 15B*	12 x 14 x 18
2 x 2½ x 12	3 x 4 x 10B	4 x 5 x 15	5 x 6 x 11	8 x 8 x 11B	6 x 8 x 18B	8 x 10 x 15A	10 x 12 x 15C*	14 x 16 x 18
	3 x 4 x 14		5 x 6 x 11C		6 x 8 x 18C	8 x 10 x 15B	10 x 12 x 18*	
	4 x 5 x 10B		5 x 6 x 15		6 x 8 x 20	8 x 10 x 17B	*Model 411 Pumps Only	

410 SERIES

ENGINEERING DATA

MATERIALS OF CONSTRUCTION

SECTION **410** PAGE **73**
 DATED **MARCH 2004**
 SUPERSEDES PAGE 73
 DATED JULY 1985

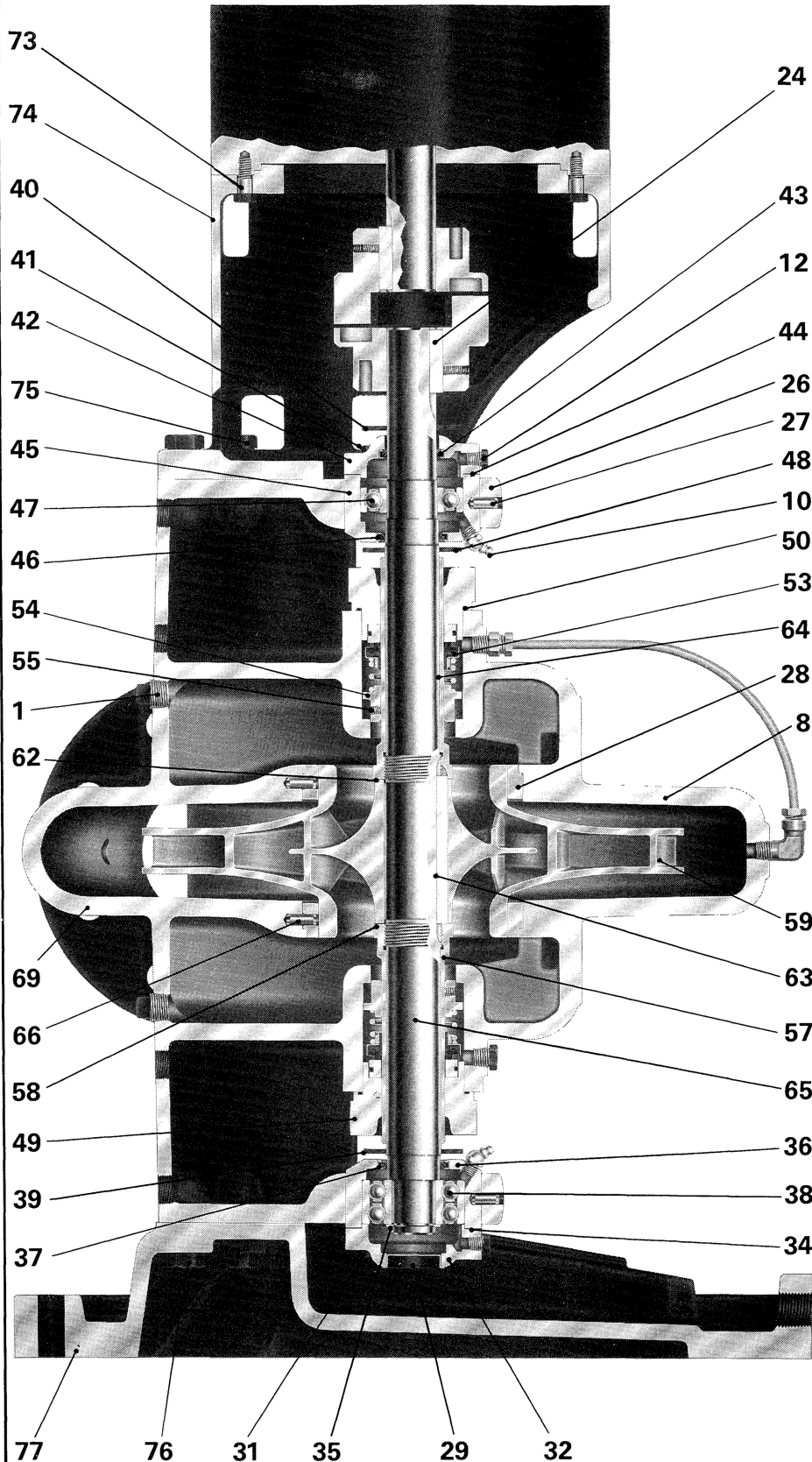

Pc No	Descrip. (*Not Shown)	PUMP CONSTRUCTION			
		Bronze Fitted	All Bronze	All Iron	Stain. Steel
1	Plug	Mall. Iron	Bronze	Mall. Iron	Stain. Stl.
2	*Plug	A197	Wrought	A197	AISI 316
6	*Capscrew	Steel	Steel	Steel	Stain. Stl.
7	*Capscrew	SAE 2	SAE 2	SAE 2	AISI 316
8	Casing Half	Cast Iron A48	Bronze B62	Cast Iron A48	Stain. Stl. ACI CF8M
9	*Gasket	Buna-N Treated Cellulose			
10	Gr. Ftg.	Steel Zerk			
12	Plug	Malleable Iron ASTM A197			
18	*Nut	Bronze Wrought	Steel SAE 2	Stain. Stl. AISI 316	
19	*Washer	Cad. Plated Steel	Bronze Wrought	Cad. Plated Steel	Stain. Stl. AISI 316
20	*Gland Clamp	Cast Iron A48	Bronze B62	Cast Iron A48	Stain. Stl. ACI CF8M
21	*Gland	Cast Iron A48	Bronze B62	Cast Iron A48	Stain. Stl. ACI CF8M
22	*Swing Bolt	Cad. Plated Steel	Silicon Bronze Wrought	Cad. Plated Steel	Stain. Stl. AISI 316
23	*Packing	Graphited Acrylic			
24	Key	Steel Wrought			
25	*Capscrew	Steel SAE 2	Bronze Wrought	Steel SAE 2	Stain. Stl. AISI 316
26	Bearing Cap	Cast Iron A48	Bronze B62	Cast Iron A48	Stain. Stl. ACI CF8M
27	Pin	Cad. Plated Steel	Stain. Steel AISI 416	Cad. Plated Steel	Stain. Stl. AISI 316
28	Case Ring	Bronze ASTM B62	Cast Iron A48	Stain. Stl. ACI CF8M	
29	Protector	Steel Wrought			
31	Capscrew	Steel SAE 2			
32	Cart. Cap	Cast Iron ASTM A48			
34	Gasket	Buna-N Treated Cellulose			
35	Ret. Ring	Spring Steel			
36	Cartridge	Cast Iron ASTM A48			
37	Gr. Seal	Buna-N and Steel			
38	Bearing	Steel Commercial			
39	Slinger	Neoprene			
40	Slinger	Neoprene			
41	Capscrew	Steel SAE 2			
42	Cart. Cap	Cast Iron ASTM A48			
43	Gr. Seal	Buna-N and Steel			
44	Gasket	Buna-N Treated Cellulose			
45	Cartridge	Cast Iron ASTM A48			
46	Gr. Seal	Buna-N and Steel			
47	Bearing	Steel Commercial			
48	Slinger	Neoprene			
49	Gland	Cast Iron A48	Bronze B62	Cast Iron A48	Stain. Stl. ACI CF8M
50	O-Ring	Buna-N			
52	*Lantern Ring	Bronze ASTM B62	Cast Iron A48	Stain. Stl. ACI CF8M	
53	Seal	Stain. Stl. (1)	Stain. Stl. (2)	Stain. Stl. (1)	Stain. Stl. (2)
54	Collar	Bronze ASTM B62	Cast Iron A48	Stain. Stl. AISI 316	
55	Setscrew	Stainless Steel AISI 316			
56	*Bushing	Bronze ASTM B62	Cast Iron A48	Stain. Stl. AISI 316	
57	Sleeve	Bronze High Lead Tin	Stain. Stl. AISI 316		
58	Gasket	DuPont TFE Coated Steel			
59	Impeller	Bronze ASTM B584	Cast Iron A48	Stain. Stl. ACI CF8M	
61	*Imp. Ring	Bronze ASTM B62	Cast Iron A48	Stain. Stl. ACI CF8M	
62	Gasket	DuPont TFE Coated Steel			
63	Key	Stain. Stl. AISI 416	Stain. Stl. AISI 316	Stain. Stl. AISI 416	Stain. Stl. AISI 316
64	Sleeve	Bronze High Lead Tin	Stain. Stl. AISI 316		
65	Shaft	P.S. 1-5 Alloy Stl. (3)	Stl. AISI C1045 (3)	Stl. AISI C1045 (3)	Stain. Stl. AISI 316
66	Pin	Cad. Plated Steel	Stain. Steel AISI 416	Cad. Plated Steel	Stain. Steel AISI 316
67	*Pin	Cad. Plated Steel	Stain. Steel AISI 416	Cad. Plated Steel	Stain. Steel AISI 316
68	*Pin	Cad. Plated Steel	Stain. Steel AISI 416	Cad. Plated Steel	Stain. Steel AISI 316
69	Casing Half	Cast Iron A48	Bronze B62	Cast Iron A48	Stain. Stl. ACI CF8M
70	*Drive Screw	Steel Bronze Plated			
71	*Nameplate	Stainless Steel AISI 303			
73	Capscrew	Steel SAE 2			
74	Bracket	Cast Iron ASTM A48			
75	Capscrew	Steel SAE 2			
76	Capscrew	Steel SAE 2			
77	Base	Cast Iron ASTM A48			

†DUPONT registered trademark.

All material specifications are in accordance with ASTM unless otherwise noted. (1) B30P66 171 (JC) (2) XP66 1C1 (JC) (3) AISI 416 chrome steel heat treated power series 6B-7.

410 SERIES ENGINEERING DATA DESIGN DETAILS

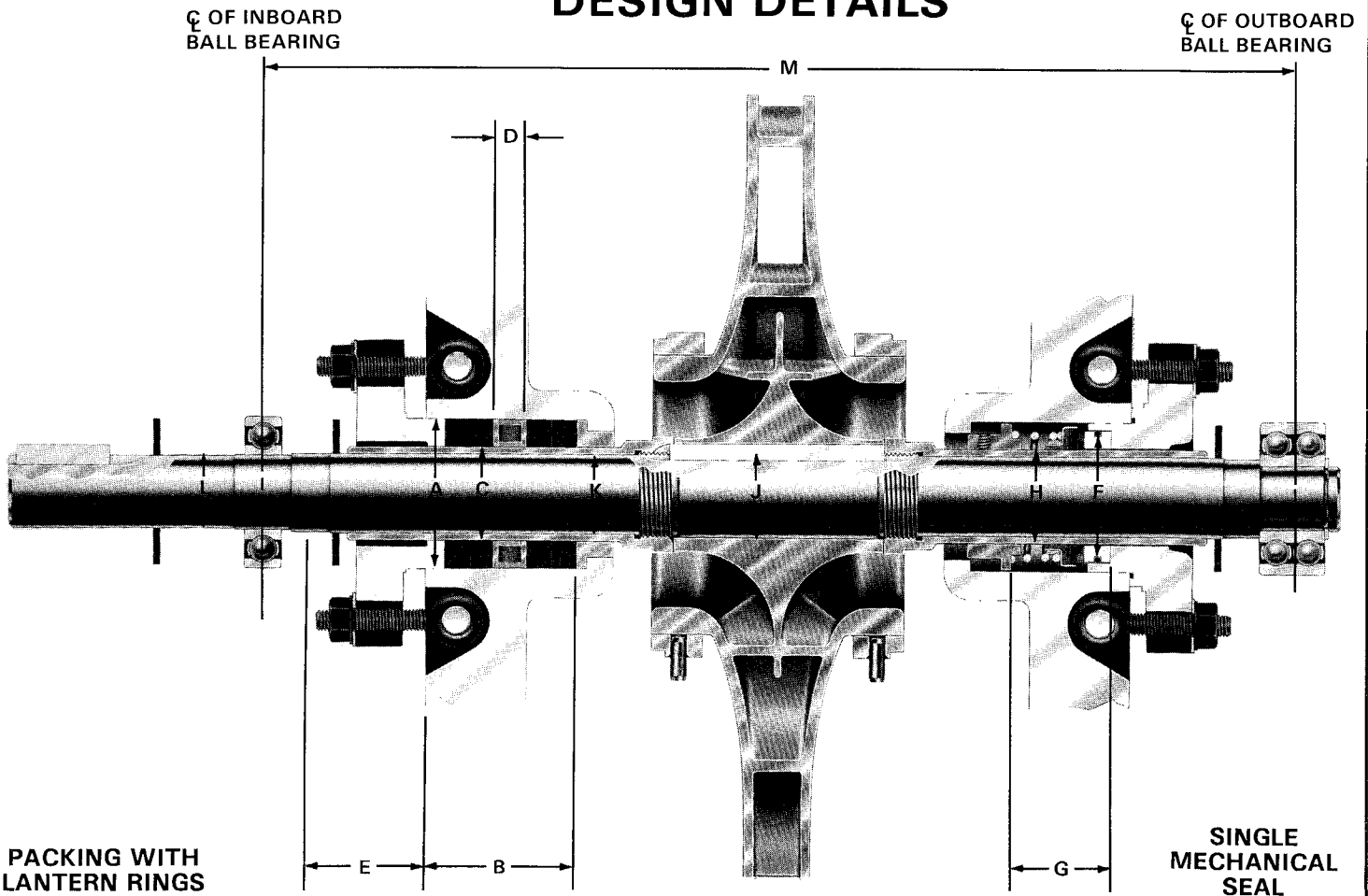

PUMP PART		DIMENSION	POWER SERIES 1	POWER SERIES 2	POWER SERIES 3	POWER SERIES 4	POWER SERIES 5	POWER SERIES 6B	POWER SERIES 7
STUFFING BOX	PACKING	A Stuffing Box Bore Diameter	2-1/16	2-7/16	2-13/16	3-1/16	3-7/16	3-11/16	3-15/16
		B Stuffing Box Depth	2-3/8	3-1/8	3	3-1/2	3-3/4	3-3/4	3-7/8
		C Outside Dia., Sleeve for Packing	1-1/8	1-1/2	1-3/4	2	2-3/8	2-1/2	2-7/8
		— No. of Packing Rings without Lantern Ring	10	12	10	12	12	12	14
		— Total number of Packing Rings with Lantern Ring	8	10	8	10	10	10	12
		— No. of rings in front of Lantern Ring	1	2	2	2	2	2	3
	M. SEAL	D Width of Lantern Ring	1/2	5/8	5/8	5/8	3/4	3/4	3/4
		E Distance from Box to Nearest Obstruction	1-1/4	1-5/8	1-11/16	1-11/16	2	2-3/8	2-1/2
SHAFT	F Dia. of Mechanical Seal Seat	1-3/4	2-1/8	2-1/2	2-3/4	3-1/4	3-3/8	3-3/4	
	G Length of Mechanical Seal	1-1/2	1-9/16	1-7/8	2	2-3/8	2-3/8	2-7/8	
	H Outside Dia., sleeve for Mech. Seal	1-1/8	1-1/2	1-3/4	2	2-3/8	2-1/2	2-7/8	
	J Dia. at Impeller (Max. Shaft Dia.)	1-1/8	1-3/8	1-5/8	1-7/8	2-1/8	2-3/8	2-3/4	
	K Diameter at Shaft Sleeve	7/8	1-1/4	1-1/2	1-3/4	2	2-1/4	2-5/8	
BALL BEARINGS	L Diameter at Coupling End	3/4	1-1/8	1-3/8	1-1/2	1-3/4	2-1/8	2-1/2	
	— Max. deflection at Sealing Face	.002	.002	.002	.002	.002	.002	.002	
	— Ball Bearing No. (Inboard Radial)	204	206	207	208 †	309	211	213	
	— Ball Bearing No. (Outboard Thrust)	5303	5305	5306	5307	5309	5211	5213	
	M Bearing Centers	14-3/4	18-3/8	19-3/8	21-1/4	24	28-3/8	33-1/8	
	— Minimum Life of Bearing under worst conditions of load (*)	6 YEARS	6 YEARS	6 YEARS	6 YEARS	6 YEARS	6 YEARS	6 YEARS	

*Average life of bearing is 5 times minimum life.

†5208 is provided as standard on 5 x 6 x 11B when operating at 3500 R.P.M. only.

MAXIMUM CASE WORKING PRESSURE is the sum of the differential pressure and the suction pressure. Table 2 indicates the maximum case working pressure for the 410 Series Split Case Pumps in various materials and at various operating temperatures. These maximum allowable pressures are based on wall thickness for the particular series of pumps, ratings for American Standard Flange Specifications, see Table 1, and take into account the material at various allowable temperatures. Table 1 offers the available casing materials and flange ratings for the 410 Series Split Case Pumps.

TABLE 1 PUMP CASING MATERIAL	MINIMUM REQUIREMENT FOR STANDARD SUCTION AND DISCHARGE FLANGES		PIPE SIZE	CODE
	A.S.A. SPEC.	CLASSIFICATION		
Cast Iron ASTM A48	B16.1	125 PSI Flat Face	1-12	A
		250 PSI Flat Face	14-24	B
Bronze ASTM B62	B16.24	150 PSI Flat Face	All	D
		300 PSI Flat Face		C
Stainless Steel ASTM 296 Grade CF8M	B16.5	150 PSI Flat Face	All	E
		300 PSI Flat Face		C

Maximum Hydrostatic Pressure 1 1/2 times maximum case working pressure at 100°F.

EXAMPLE: A model 410 Pump with a bronze casing has been selected for operating at a case working pressure of 240 P.S.I.G. at 150°F. Enter Table 2 at 150°F. and read upward to 240 P.S.I.G. It is determined that the selection is within the recommended maximum case working pressure area for 300 PSI flanges and is therefore acceptable. Note that the example exceeds the maximum case working pressure unit if the material selected would have been 125 PSI flanged cast iron or 150 PSI flanged bronze.

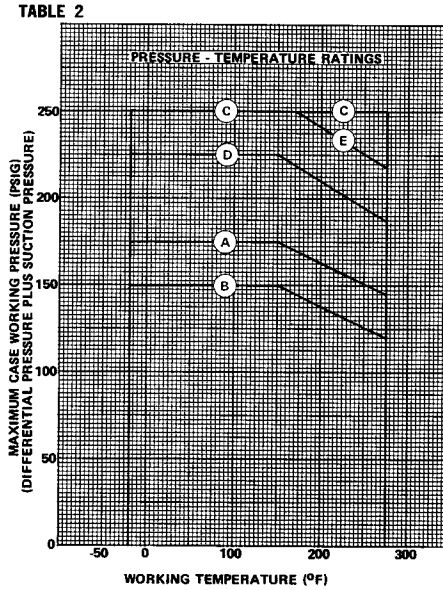

EXTERNAL INERTIA OR FLY-WHEEL EFFECT is the Kinetic energy stored in the rotating assembly that must be overcome when the pump impeller is caused to rotate within the casing. This energy frequently must

be calculated to determine the torque required to start, accelerate or decelerate the pump. If the acceleration is rapid, the torque may be several times greater than the torque required to run the pump at normal or constant speed. WR^2 values in $LBS\text{-}FT^2$ are provided for these calculations. See tables 3 thru 8.

WR^2 values given in tables are for bronze impeller... $LB\text{-}FT^2$

EXAMPLE 1: Find WR^2 value for a 15" diameter 8x10x15B bronze fitted pump handling cold water. From chart the "WET" value for a 15" diameter impeller... **10.38 $LB\text{-}FT^2$**
Add power series 5 rotating element less impeller... **0.15 $LB\text{-}FT^2$**
Total **10.53 $LB\text{-}FT^2$**

EXAMPLE 2: Find WR^2 value for a 15" diameter 8 x 10 x 15B all iron pump handling 0.67 specific gravity gasoline. From chart select "DRY" value and correct for difference in materials.
Sp. Gr. cast iron x 9.29 $LB\text{-}FT^2$... **7.54 $LB\text{-}FT^2$**
Sp. Gr. bronze x 9.29 $LB\text{-}FT^2$... **0.73 $LB\text{-}FT^2$**
Take difference ("WET"- "DRY") values and correct for difference in specific gravities.
1.09 x 0.67... **0.73 $LB\text{-}FT^2$**
Add power series 5 rotating element less impeller... **0.15 $LB\text{-}FT^2$**
Total **8.42 $LB\text{-}FT^2$**

TABLE 3 SPECIFIC GRAVITY OF COMMON METALS		TABLE 4 WR^2 VALUE OF ROTATING ELEMENT LESS IMPELLER	
METALS	S.G.	POWER SERIES	WR^2
Bronze	8.86	1	0.006
Cast Iron	7.20	2	0.020
		3	0.038
		4	0.075
Carbon Steel	7.84	5	0.154
		6B	0.294
Stainless Steel	7.90	7	0.536

TABLE 5														TABLE 6														
2x2 1/2x9		2x2 1/2x10		2 1/2x3x10B		3x4x10B		4x5x10B		4x5x11A		4x5x11C		5x6x11 6x8x11		5x6x11C		8x8x11B		8x10x12		10x12x12B						
DIA.	DRY	WET	DRY	WET	DRY	WET	DRY	WET	DRY	WET	DRY	WET	DRY	WET	DRY	WET	DRY	WET	DRY	WET	DRY	WET	DRY	WET				
10"	—	—	—	—	—	—	1.17	1.30	—	—	—	—	—	—	—	—	—	—	2.91	3.43	4.10	4.60	5.80	6.75				
9.5"	—	—	0.72	0.88	0.84	0.95	0.98	1.10	0.90	1.03	—	—	—	—	—	—	—	—	2.55	3.00	3.80	4.00	5.32	6.10				
9.0"	0.56	0.63	0.60	0.70	0.70	0.85	0.80	0.90	0.80	0.90	—	—	—	—	—	—	—	—	2.15	2.45	3.40	3.80	5.00	5.60				
8.5"	0.37	0.43	0.46	0.54	0.62	0.73	0.70	0.75	0.68	0.75	—	—	—	—	—	—	—	—	1.80	2.10	2.90	3.20	4.90	5.50				
8.0"	0.28	0.32	0.40	0.47	0.56	0.65	0.56	0.60	0.56	0.63	—	—	—	—	—	—	—	—	1.60	1.85	2.65	3.10	4.80	5.40				
7.5"	0.23	0.26	0.36	0.41	0.47	0.56	0.46	0.50	0.48	0.54	—	—	—	—	—	—	—	—	1.45	1.65	2.50	2.90	4.60	5.40				
7.0"	0.19	0.22	0.29	0.33	0.42	0.49	0.36	0.40	0.43	0.46	—	—	—	—	—	—	—	—	1.30	1.45	2.40	2.80	4.40	5.20				
6.5"	0.18	0.19	0.27	0.31	0.39	0.44	0.32	0.36	0.38	0.41	—	—	—	—	—	—	—	—	1.20	1.35	2.35	2.60	4.20	5.00				
6.0"	0.16	0.18	—	—	0.35	0.41	0.28	0.31	0.33	0.36	—	—	—	—	—	—	—	—	1.06	1.15	2.00	2.40	4.10	4.80				
IMP. WGT.	10#		12#		14#		18#		15#		15#		17#		26#		22#		27#		32#		29#		43#		59#	

TABLE 7														TABLE 8																				
3x4x14		4x5x15		5x6x15		8x10x15 6x8x15		8x10x15B		10x12x15B		10x12x15C		12x14x15B		4x6x18B		5x6x17		6x8x18A 6x8x18B 6x8x18C		6x8x20		8x10x17B		10x12x18		12x14x18		14x16x18				
DIA.	DRY	WET	DRY	WET	DRY	WET	DRY	WET	DRY	WET	DRY	WET	DRY	WET	DRY	WET	DRY	WET	DRY	WET	DRY	WET	DRY	WET	DRY	WET	DRY	WET	DRY	WET				
15	—	—	4.51	5.18	6.18	6.76	7.39	8.51	9.29	10.4	9.21	10.0	14.5	17.5	14.3	17.7	19.5	—	—	—	—	—	—	—	—	—	—	—	—	—	—			
14.5	—	—	3.80	4.50	5.40	6.00	6.75	7.50	7.75	8.80	8.50	9.25	13.5	16.2	14.0	16.5	19.0	—	—	—	—	—	—	—	—	—	—	—	—	—	—			
14.0	3.62	4.36	3.50	3.90	4.60	5.20	6.00	6.75	6.75	7.75	8.00	9.00	12.2	14.4	13.0	15.0	18.5	—	—	—	—	—	—	—	—	—	—	—	—	—	—			
13.5	3.10	3.60	3.00	3.40	4.20	4.50	5.40	6.00	6.10	7.00	7.50	8.50	11.3	12.2	12.5	14.5	18.0	—	—	—	—	—	—	—	—	—	—	—	—	—	—			
13.0	2.70	3.10	2.55	2.95	3.60	3.90	5.00	5.50	5.70	6.25	6.75	7.60	10.5	11.4	11.8	13.9	17.5	—	—	—	—	—	—	—	—	—	—	—	—	—	—			
12.5	2.25	2.65	2.20	2.60	3.20	3.50	4.50	5.00	5.10	5.80	6.50	7.25	10.0	11.0	11.0	13.0	17.0	—	—	—	—	—	—	—	—	—	—	—	—	—	—			
12.0	1.98	2.30	1.95	2.25	3.05	3.20	4.10	4.40	4.80	5.30	6.25	7.00	—	—	—	—	—	—	—	—	—	—	—	—	—	—	—	—	—	—	—			
11.5	1.60	1.90	1.70	2.00	2.70	2.98	3.70	4.00	4.50	5.00	—	—	—	—	—	—	—	—	—	—	—	—	—	—	—	—	—	—	—	—	—			
11.0	1.40	1.65	1.50	1.75	2.50	2.70	3.30	3.55	4.10	4.40	—	—	—	—	—	—	—	—	—	—	—	—	—	—	—	—	—	—	—	—	—			
10.5	1.25	1.50	—	—	2.30	2.45	3.00	3.20	3.70	4.10	—	—	—	—	—	—	—	—	—	—	—	—	—	—	—	—	—	—	—	—	—			
10.0	1.10	1.35	—	—	2.05	2.25	2.85	3.10	3.50	3.80	—	—	—	—	—	—	—	—	—	—	—	—	—	—	—	—	—	—	—	—	—			
IMP. WGT.	28#		30#		45#		56#		59#		70#		85#		87#		IMP. WGT.		60#		49#		65#		77#		68#		98#		115#		135#	

410 SERIES ENGINEERING DATA QUIET PUMP SELECTION

TABLE 9 PUMP SIZE	MAX. IMP. DIA.	CUT- WATER DIA.	QUIET IMP. DIA.	SPHERE SIZE DIA.
2x2½x9	9.0	10.4	8 ¹ / ₁₆	⅛
2x2½x10	9.5	10.3	8 ¹ / ₁₆	¼
2x2½x12	12.0	13.3	11¼	¼
2½x3x10B	9.5	10.3	8 ¹ / ₁₆	⅜
2½x3x12	12.0	13.3	11⅜	⅜
3x4x10B	10.0	10.5	8 ¹ / ₁₆	½
3x4x14	14.0	15.4	13¼	⅝
4x5x10B	9.5	10.6	9¼	⅝
4x5x11A	11.3	12.8	10⅞	⅝
4x5x11C	11.3	12.8	10⅞	½
4x5x15	15.0	16.4	13 ¹⁵ / ₁₆	⅝
4x6x18B	18.3	22.6	18¼	⅞
5x6x11	11.0	12.6	10¾	1
5x6x11C	11.0	12.6	10¾	⅝
5x6x15	15.0	16.4	13⅞	1 ¹³ / ₁₆
5x6x17	16.5	17.4	14¾	1 ¹¹ / ₁₆
6x8x11	11.0	12.8	10⅞	1
8x8x11B	12.0	13.3	11¼	1¼
6x8x15	15.0	16.6	14⅞	1 ¹⁵ / ₁₆
6x8x18A	18.0	20.5	17⅞	1
6x8x18B	18.0	20.5	17⅞	1
6x8x18C	18.0	20.5	17⅞	1
6x8x20	19.5	20.6	17 ¹⁷ / ₁₆	1 ¹³ / ₁₆
8x10x12	12.0	14.4	12¼	1 ¹⁵ / ₁₆
8x10x15A	15.0	16.8	14¼	1 ¹⁵ / ₁₆
8x10x15B	15.0	16.8	14¼	1 ¹⁵ / ₁₆
8x10x17B	17.5	18.5	15¾	1 ¹⁵ / ₁₆
PUMP SIZE	MAX. IMP. DIA.	CUT- WATER DIA.	QUIET IMP. DIA.	SPHERE SIZE DIA.
10x12x12B	12.0	14.0	11 ¹⁵ / ₁₆	1 ¹⁵ / ₁₆
10x12x15B	15.0	17.1	14 ¹⁴ / ₁₆	1 ¹⁷ / ₁₆
10x12x15C	15.0	17.1	14 ¹⁴ / ₁₆	1⅞
10x12x18	18.0	20.5	17 ¹⁷ / ₁₆	1 ¹⁹ / ₁₆
12x14x15B	15.0	17.8	15	1 ¹⁷ / ₁₆
12x14x18	18.0	21.1	18	1 ¹⁹ / ₁₆
14x16x18	18.0	22.0	18	1½

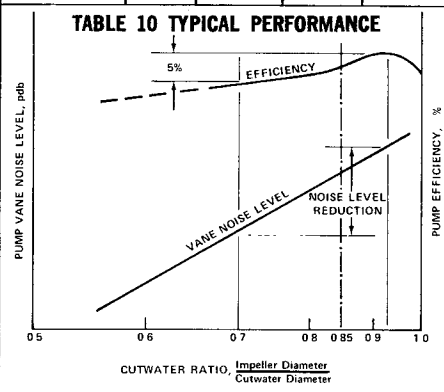

QUIET PUMP operation is always desirable and sometimes essential. One of the most important factors for noise control in a pumping installation is the correct selection of a pumping unit for the system. To insure that the pump will run quietly, it should be selected so that it will operate as close as possible to the best efficiency point. At this point the hydraulic shock within the pump is at a minimum since the flow angle of the fluid from the tip of the impeller is correct for the casing design. Every pump is designed for the best efficiency point and operation at any other point on the characteristic curves is a compromise. The amount of turbulence on either side of the best efficiency point increases as the point of operation is moved along the curve from the maximum efficiency. Therefore, the greater the turbulence, the greater the noise generated.

Hydraulic shock is also a factor if the periphery of the impeller passes too close to the cutwater. If the ratio of the impeller diameter to the cutwater diameter in centrifugal pumps is greater than 0.92, the pump is likely to be hydraulically noisy. In such instances the hydraulic pulses are actually differential pressures that occur when the impeller vanes pass the cutwater. Cutwater ratios of 0.9 to 0.95 are typical; however, significantly lower noise levels are achieved in pumps designed with a ratio of 0.7 to 0.75. Although there is an optimum gap for pump efficiency, increases of only 3%-5% may be realized by using the optimum. A cutwater ratio of 0.85 is commonly specified by practicing engineers, thereby realizing a minimum reduction in pump efficiency with a mean reduction in noise level. Table 9 offers recommended quiet impeller diameter at 85% cutwater ratio.

BEARING LIFE is based on the radial and thrust loads imposed on the bearings at the specific operating head and suction pressure. The Split case pump is designed for a six year minimum B₁₀ life at the maximum recommended loads. Bearing life at any other point of greater capacity on the curves will greatly exceed the minimum life shown. Average bearing life is equal to five (5) times the minimum bearing life. Tables 11, 12, 13 and 14 will enable you to determine the minimum radial and thrust bearing life for any type 410 Series pump size. SHAFT DEFLECTION is the consequence of the unbalanced hydraulic force acting inside the pump on the impeller and shaft in a radial direction. This unbalance occurs when the pump is operating away from its best efficiency point. At shut-off condition (zero flow) the unbalance is greatest and therefore the resultant radial load is maximum. *Radial load and shaft deflection approach zero at the best efficiency point of the pump.* 410 Series pumps are designed for a maximum deflection of .002" at the mechanical seal faces when operating at the maximum recommended differential pressure. Deflection in a twin volute pump is minimized by a splitter blade that is cast within the casing thereby nearly balancing the resultant forces acting on the shaft. See Table 13 on page 77.

PROCEDURE FOR DETERMINING MAXIMUM SHAFT DEFLECTION AND MINIMUM BEARING LIFE.

1. Determine the proper Pump Size, approximate Shut-Off Head in feet, Power Series number, and Speed from the range charts illustrated in the 410 Bulletin.
2. From table 11 on page 77 determine the Pump Size Factor based on Pump Size and R.P.M.
3. On table 13 on page 77 locate the correct Shut-Off Head in feet and read across to the proper Pump Size Factor and down to the applicable Power Series. Note the Load Factor in the process. Read to the scale on the left for the maximum Shaft Deflection value.
4. From table 14 on page 77 using the Load Factor from step 3 above read across to the correct Power Series number and down for the minimum Bearing Life in hours.

NOTE: 1. One (1) year life is based on 8740 HOURS (continuous operation). 2. Additional bearing information can be found on page 74. 3. Specific information on Bearing Life and Shaft Deflection can be obtained from the factory.

410 SERIES ENGINEERING DATA SHAFT DEFLECTION AND BEARING LIFE

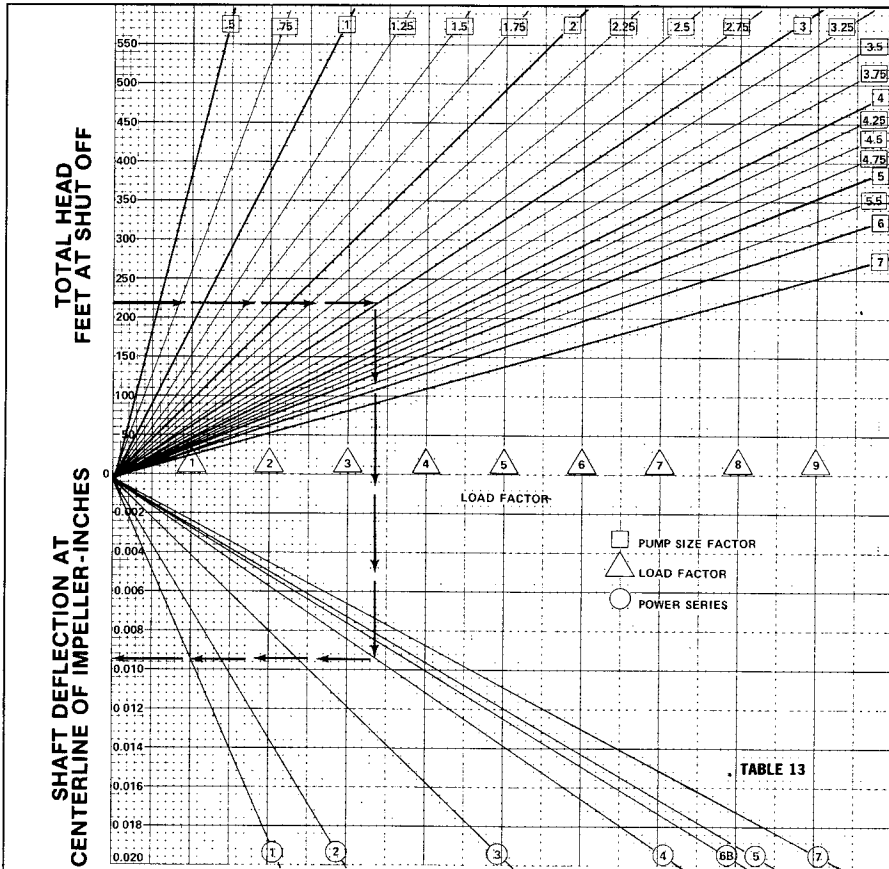

The charts reflect the *worst* impeller, shaft sleeves, wear-possible conditions at pump ing rings and packing will re-duce the amount of deflection.

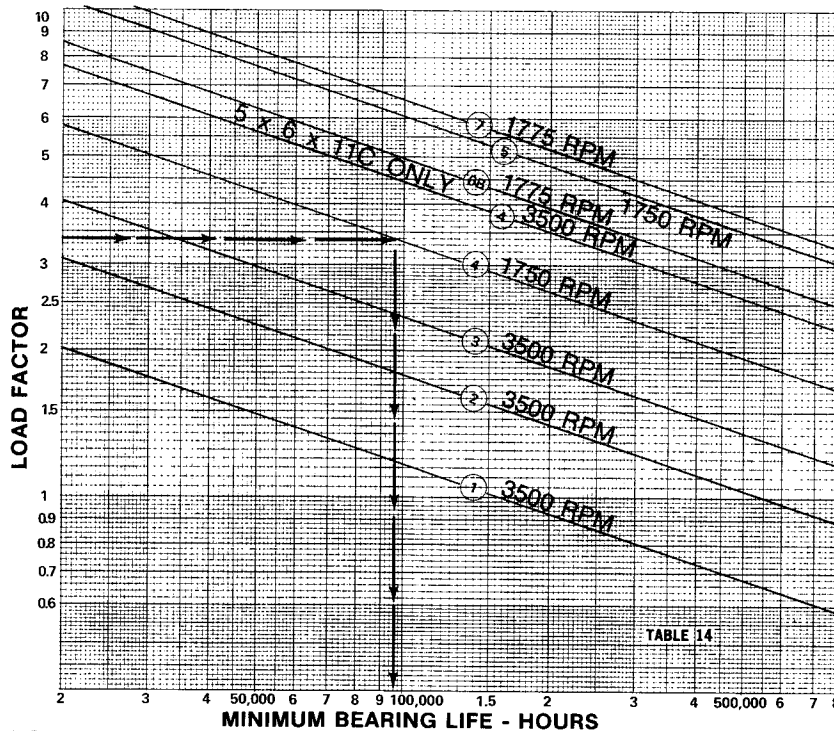

TABLE 11 PUMP SIZE	POWER SERIES	PUMP SIZE FACTOR		
		3500 RPM	1750 RPM	1150 RPM
2x2½x9	1	0.40	0.50	
2x2½x10	1	0.55	0.65	
2x2½x12	1		0.65	0.80
2½x3x10B	2	1.00	1.00	
2½x3x12	2		1.00	1.20
3x4x10B	2	1.25	1.50	
3x4x14	2		1.40	1.60
4x5x10B	2	1.30	1.40	
4x5x11A	3		2.00	2.25
4x5x11C	3	1.50	1.70	
4x5x15	3		2.00	2.25
4x6x18B	4		1.70	1.80
5x6x11	4		4.00	4.50
5x6x11C	4	2.00	2.13	
5x6x15	4		3.00	3.25
5x6x17	4		3.00	3.25
6x8x11	4		4.00	4.50
8x8x11B	4		5.25	5.50
6x8x15	5		3.75	4.00
6x8x18A	5		3.00	3.25
6x8x18B	5		2.75	3.50
6x8x18C	5		3.75	4.75
6x8x20	5		3.20	3.40
8x10x12	5		3.50	4.00
8x10x15A	5		4.00	4.50
8x10x15B	5		4.50	5.00
8x10x17B	5		4.00	5.00

PUMP SIZE	POWER SERIES	PUMP SIZE FACTOR		
		1775 RPM	1175 RPM	885 RPM
10x12x12B	6B	4.50	5.00	
10x12x15B	6B	3.25	3.75	
10x12x15C	6B	3.50	4.75	
10x12x18	6B	3.25	3.75	
12x14x15B	7	4.75	5.50	
12x14x18	7	4.00	4.50	
14x16x18	7		7.00	7.50

EXAMPLE: A 5x6x15 pump operating at 1750 R.P.M. on a No. 4 power series with a shut-off head of 225 ft. T.D.H. has a Size Factor of 3.00, a Load Factor of 3.35, a maximum Shaft Deflection at the centerline of the impeller of .0092, and a minimum Bearing Life of 97,000 hours @ 1750 R.P.M.

TABLE 12	CHART SPEED R.P.M.	DESIRED SPEED R.P.M.	MULTIPLY CHART LIFE BY
SPEED (R.P.M.) FACTORS	3500	1750	2
	3500	1150	3
	1750	1150	1.5
	1775	1175	1.5
	1775	875	2
	1175	875	1.3

AURORA 410 SERIES

ENGINEERING DATA

PUMP NOZZLE LOADING PUMPS WITH GROUTED BASEPLATES

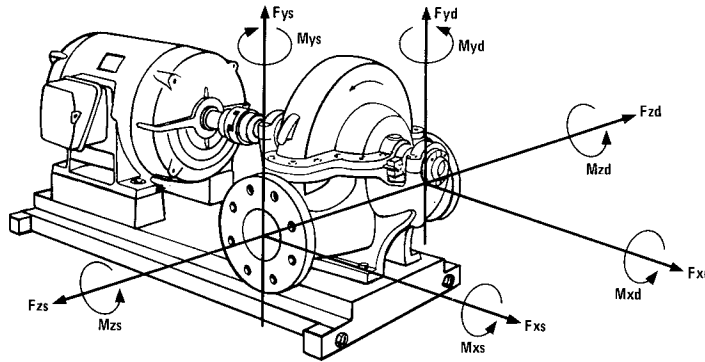

PUMP SIZE		FORCES - LBS.			MOMENTS - FT. LBS.		
		Fx	Fy	Fz	Mx	My	Mz
2 x 2-1/2 x 9	DISCHARGE	200	250	750	250	350	300
	SUCTION	200	250	750	250	350	300
2 x 2-1/2 x 10	DISCHARGE	200	250	750	250	350	300
	SUCTION	200	250	750	250	350	300
2 x 2-1/2 x 12	DISCHARGE	200	250	750	250	350	300
	SUCTION	200	200	750	250	350	300
2-1/2 x 3 x 10	DISCHARGE	500	550	1350	600	800	700
	SUCTION	450	550	1350	600	800	700
2-1/2 x 3 x 12	DISCHARGE	400	500	1350	600	800	700
	SUCTION	400	500	1350	600	800	700
3 x 4 x 10	DISCHARGE	450	550	1350	600	800	700
	SUCTION	400	500	1350	600	800	700
3 x 4 x 14	DISCHARGE	400	450	1400	600	800	700
	SUCTION	350	400	1400	600	800	700
4 x 5 x 10	DISCHARGE	450	550	1400	650	800	700
	SUCTION	400	500	1400	650	800	700
4 x 5 x 11	DISCHARGE	250	850	750	1200	550	1400
	SUCTION	250	850	750	1200	550	1400
4 x 5 x 15	DISCHARGE	700	850	2200	1200	1600	1450
	SUCTION	650	750	2200	1200	1600	1450
4 x 6 x 18	DISCHARGE	650	800	2200	1250	1600	1450
	SUCTION	550	700	2200	1250	1600	1450
5 x 6 x 11	DISCHARGE	800	400	2200	500	1600	600
	SUCTION	700	350	2200	500	1600	600
5 x 6 x 15	DISCHARGE	700	850	2200	1250	1600	1450
	SUCTION	600	750	2200	1250	1600	1450
5 x 6 x 17	DISCHARGE	650	800	2250	1250	1600	1500
	SUCTION	600	750	2250	1250	1600	1500
6 x 8 x 11	DISCHARGE	800	950	2200	1250	1600	1450
	SUCTION	650	750	2200	1250	1600	1450

Values tabled are for forces and moments acting alone at the suction or discharge flange.

Combined forces and moments must be reduced so:

$$\frac{F_{xd}}{F_{xdmax}} + \frac{F_{yd}}{F_{ydmax}} + \frac{F_{zd}}{F_{zdmax}} + \frac{M_{xd}}{M_{xdmax}} + \frac{M_{yd}}{M_{ydmax}} + \frac{M_{zd}}{M_{zdmax}} + \frac{F_{xs}}{F_{xsmax}} + \frac{F_{ys}}{F_{ysmax}} + \frac{F_{zs}}{F_{zsmax}} + \frac{M_{xs}}{M_{xsmax}} + \frac{M_{ys}}{M_{ysmax}} + \frac{M_{zs}}{M_{zsmax}} \leq 1.0$$

ENGINEERING DATA

DATED MARCH 1986

PUMP NOZZLE LOADING PUMPS WITH GROUTED BASEPLATES

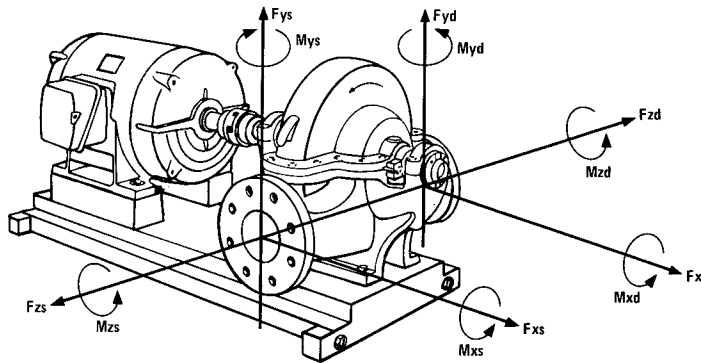

PUMP SIZE		FORCES - LBS.			MOMENTS - FT. LBS.		
		Fx	Fy	Fz	Mx	My	Mz
8 x 8 x 11	DISCHARGE	750	750	2250	1000	1600	1200
	SUCTION	650	600	2250	1000	1600	1200
6 x 8 x 15	DISCHARGE	1150	1300	3250	2100	2800	2550
	SUCTION	950	1100	3250	2100	2800	2550
6 x 8 x 18	DISCHARGE	1000	1200	3300	2150	2850	2600
	SUCTION	900	1050	3300	2150	2850	2600
6 x 8 x 20	DISCHARGE	1050	1250	3300	2200	2850	2650
	SUCTION	900	1100	3300	2200	2850	2650
8 x 10 x 12	DISCHARGE	950	1150	3300	2150	2850	2600
	SUCTION	900	1100	3300	2150	2850	2600
8 x 10 x 15	DISCHARGE	950	1150	3300	2200	2850	2600
	SUCTION	900	1100	3300	2200	2850	2600
8 x 10 x 17	DISCHARGE	950	1150	3300	2200	2850	2650
	SUCTION	900	1100	3300	2200	2850	2650
8 x 10 x 21	DISCHARGE	1650	2000	3300	4000	4350	3350
	SUCTION	1400	1700	3300	4000	4350	3350
10 x 12 x 12B	DISCHARGE	1350	1700	3350	3000	4450	4650
	SUCTION	1150	1400	3350	3000	4450	4650
10 x 12 x 15B	DISCHARGE	1300	1600	3400	3050	4500	4700
	SUCTION	1100	1350	3400	3050	4500	4700
10 x 12 x 15C	DISCHARGE	1300	1600	3400	3050	4500	4700
	SUCTION	1100	1350	3400	3050	4500	4700
10 x 12 x 18	DISCHARGE	1200	1500	3400	3050	4500	4700
	SUCTION	1000	1250	3400	3050	4500	4700
12 x 14 x 15B	DISCHARGE	1300	1700	3450	3250	4600	5050
	SUCTION	1000	1300	3450	3250	4600	5050
12 x 14 x 18	DISCHARGE	1250	1650	3500	3300	4650	5100
	SUCTION	950	1250	3500	3300	4650	5100
14 x 16 x 18	DISCHARGE	1050	1450	3600	3550	4800	5500
	SUCTION	850	1150	3600	3550	4800	5500

Values tabled are for forces and moments acting alone at the suction or discharge flange.

Combined forces and moments must be reduced so:

$$\frac{F_{xd}}{F_{xdmax}} + \frac{F_{yd}}{F_{ydmax}} + \frac{F_{zd}}{F_{zdmax}} + \frac{M_{xd}}{M_{xdmax}} + \frac{M_{yd}}{M_{ydmax}} + \frac{M_{zd}}{M_{zdmax}} + \frac{F_{xs}}{F_{xsmax}} + \frac{F_{ys}}{F_{ysmax}} + \frac{F_{zs}}{F_{zsmax}} + \frac{M_{xs}}{M_{xsmax}} + \frac{M_{ys}}{M_{ysmax}} + \frac{M_{zs}}{M_{zsmax}} \leq 1.0$$

AURORA MODEL 411 PUMPS

2" THRU 8" PUMPS
POWER SERIES NO. 1-2-3-4

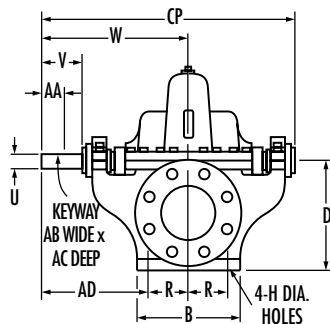

RIGHT HAND ROTATION

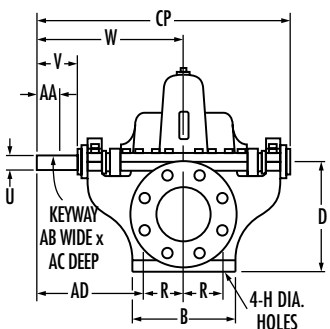
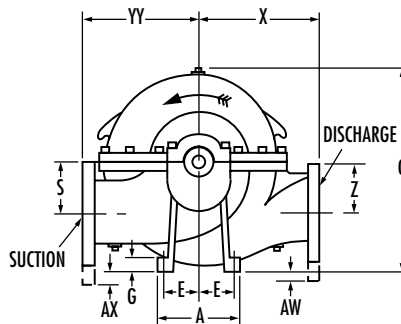

LEFT HAND ROTATION

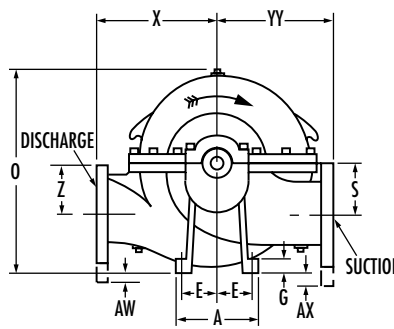

PUMP SIZE			POWER SERIES	DIMENSIONS (INCHES)																					
DISCH	SUCT	CASE BORE		A	B	D	E	G	H	O	R	S	U	V	W	X	Z	AA	AB	AC	AD	AW	AX	CP	YY
2	2-1/2	9	1	6-1/2 (165)	8 (203)	7 (178)	2-3/4 (70)	5/8 (16)	1/2 (13)	13-3/8 (340)	3-1/4 (83)	3-1/2 (89)	3/4 (19)	3-1/2 (89)	11-5/8 (295)	8-1/2 (216)	3-1/2 (89)	2 (51)	3/16 (5)	3/32 (2)	8-3/8 (213)	-	1/4 (6)	20-1/2 (521)	9 (229)
2	2-1/2	10	1	6-1/2 (165)	8 (203)	7 (178)	2-3/4 (70)	5/8 (16)	1/2 (13)	13-1/2 (343)	3-1/4 (83)	3-1/2 (89)	3/4 (19)	3-1/2 (89)	11-5/8 (295)	8-1/2 (216)	3-1/2 (89)	2 (51)	3/16 (5)	3/32 (2)	8-3/8 (213)	-	1/4 (6)	20-1/2 (521)	9 (229)
2	2-1/2	12	1	6-1/2 (165)	8 (203)	8 (203)	2-3/4 (70)	5/8 (16)	1/2 (13)	15-7/8 (403)	3-1/4 (83)	4 (102)	3/4 (19)	3-1/2 (89)	11-5/8 (295)	10 (254)	4 (102)	2 (51)	3/16 (5)	3/32 (2)	8-3/8 (213)	-	-	20-1/2 (521)	10-3/4 (273)
2-1/2	3	10	2	8 (203)	10 (254)	8 (203)	3-1/2 (89)	3/4 (19)	5/8 (16)	16 (406)	4 (102)	4 (102)	1-1/8 (29)	2-7/8 (73)	13-1/2 (343)	9-3/4 (248)	4 (102)	2-1/8 (54)	1/4 (6)	1/8 (3)	9-1/2 (241)	-	-	24 (610)	10 (254)
2-1/2	3	12	2	8 (203)	10 (254)	9 (229)	3-1/2 (89)	3/4 (19)	5/8 (16)	17-1/4 (438)	4 (102)	4-1/2 (114)	1-1/8 (29)	2-7/8 (73)	13-1/2 (343)	11 (286)	4-1/2 (114)	2-1/8 (54)	1/4 (6)	1/8 (3)	9-1/2 (241)	-	-	24 (610)	11-1/2 (292)
3	4	10	2	8 (203)	10 (254)	9 (229)	3-1/2 (89)	3/4 (19)	5/8 (16)	16-1/4 (413)	4 (102)	4-1/2 (114)	1-1/8 (29)	2-7/8 (73)	13-1/2 (343)	10 (254)	4-1/2 (114)	2-1/8 (54)	1/4 (6)	1/8 (3)	9-1/2 (241)	-	1/2 (13)	24 (610)	11 (343)
3	4	14	2	8 (203)	10 (254)	10 (254)	3-1/2 (89)	3/4 (19)	5/8 (16)	19-3/8 (492)	4 (102)	5 (127)	1-1/8 (29)	2-7/8 (73)	13-1/2 (343)	12 (305)	5 (127)	2-1/8 (54)	1/4 (6)	1/8 (3)	9-1/2 (241)	-	-	24 (610)	13 (330)
4	5	10	2	8 (203)	10 (254)	9 (229)	3-1/2 (89)	3/4 (19)	5/8 (16)	16-1/4 (413)	4 (102)	4-5/8 (117)	1-1/8 (29)	2-7/8 (73)	13-1/2 (343)	10 (254)	4-1/2 (114)	2-1/8 (54)	1/4 (6)	1/8 (3)	9-1/2 (241)	1/2 (13)	1-1/8 (29)	24 (610)	11-1/4 (286)
4	5	11	3	10 (254)	12 (305)	10 (254)	4-1/4 (108)	7/8 (22)	3/4 (19)	18-3/8 (467)	5 (127)	5 (127)	1-3/8 (35)	3 (76)	14-1/2 (368)	11-1/4 (286)	5 (127)	2-3/8 (60)	3/8 (10)	3/16 (5)	9-1/2 (241)	-	1/2 (13)	26 (660)	12-3/4 (324)
4	5	15	3	10 (254)	12 (305)	11 (279)	4-1/4 (108)	7/8 (22)	3/4 (19)	21-1/8 (537)	5 (127)	5-1/2 (140)	1-3/8 (35)	3 (76)	14-1/2 (368)	12 (305)	5-1/2 (140)	2-3/8 (60)	3/8 (10)	3/16 (5)	9-1/2 (241)	-	-	26 (660)	14 (356)
4	6	18	4	10 (254)	12 (305)	12-1/2 (318)	4-1/4 (108)	3/4 (19)	3/4 (19)	24-1/4 (616)	5 (127)	6-1/4 (159)	1-1/2 (38)	3-1/2 (89)	16 (406)	14 (356)	6-1/4 (159)	2-7/8 (73)	3/8 (10)	3/16 (5)	11 (279)	-	-	28-1/2 (724)	16 (406)
5	6	11	4	10 (254)	12 (305)	11 (279)	4-1/4 (108)	7/8 (22)	3/4 (19)	19-3/4 (502)	5 (127)	5-1/2 (140)	1-1/2 (38)	3-1/2 (89)	16 (406)	11-1/4 (286)	5-1/2 (140)	2-7/8 (73)	3/8 (10)	3/16 (5)	11 (279)	-	3/4 (19)	28-1/2 (724)	13-1/4 (337)
5	6	15	4	10 (254)	12 (305)	12-1/2 (318)	4-1/4 (108)	7/8 (22)	3/4 (19)	22-1/2 (572)	5 (127)	6-1/4 (159)	1-1/2 (38)	3-1/2 (89)	16 (406)	13-1/4 (337)	6-1/4 (159)	2-7/8 (73)	3/8 (10)	3/16 (5)	11 (279)	-	-	28-1/2 (724)	15 (343)
5	6	17	4	10 (254)	12 (305)	12-1/2 (318)	4-1/4 (108)	7/8 (22)	3/4 (19)	22-1/2 (572)	5 (127)	6-1/4 (159)	1-1/2 (38)	3-1/2 (89)	16 (406)	14 (356)	6-1/4 (159)	2-7/8 (73)	3/8 (10)	3/16 (5)	11 (279)	-	-	28-1/2 (724)	15 (343)
6	8	11	4	10 (254)	12 (305)	12-1/2 (318)	4-1/4 (108)	7/8 (22)	3/4 (19)	21-7/8 (556)	5 (127)	6-1/4 (159)	1-1/2 (38)	3-1/2 (89)	16 (406)	11-3/4 (304)	6-1/4 (159)	2-7/8 (73)	3/8 (10)	3/16 (5)	11 (279)	-	1-1/4 (32)	28-1/2 (724)	14-1/2 (368)
8	8	11	4	10 (254)	12 (305)	12-1/2 (318)	4-1/4 (108)	7/8 (22)	3/4 (19)	21-3/4 (552)	5 (127)	6-1/4 (159)	1-1/2 (38)	3-1/2 (89)	16 (406)	12 (305)	6-1/4 (159)	2-7/8 (73)	3/8 (10)	3/16 (5)	11 (279)	1-1/4 (32)	1-1/4 (32)	28-1/2 (724)	14-1/2 (368)

NOTES:

- All dimensions in inches (mm).
- Dimensions may vary ± 3/8" (10).
- Not for construction purposes unless certified.
- Discharge and suction flanges - ANSI Standard flat face.

STD. 125# FLANGES	OPT. 250# FLANGES
-------------------	-------------------

AURORA MODEL 411 PUMPS

6" THRU 14" PUMPS

POWER SERIES NO. 5-6B-7

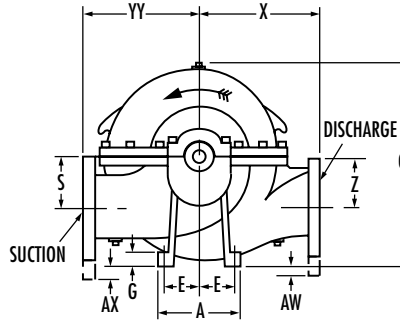
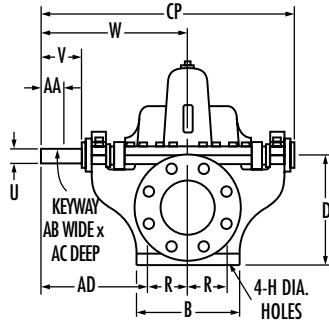

RIGHT HAND ROTATION

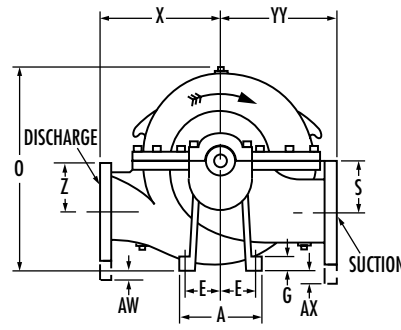
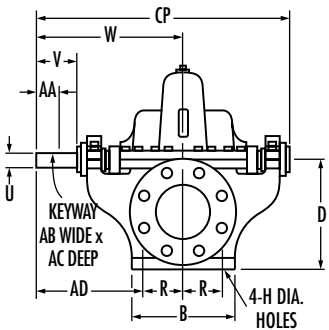

LEFT HAND ROTATION

PUMP SIZE			CASE BORE	POWER SERIES	A	B	D	E	G	H	O	R	S	U	V	W	X	Z	AA	AB	AC	AD	AW	AX	CP	YY
DISCH	SUCT																									
6	8	15	5	12 (305)	14 (356)	13-1/2 (343)	5 (127)	1 (25)	7/8 (22)	24-7/8 (632)	6 (152)	6-3/4 (171)	1-3/4 (44)	4 (102)	18 (457)	14-1/4 (362)	6-3/4 (171)	2-7/8 (73)	3/8 (10)	3/16 (5)	12 (305)	-	3/4 (19)	32 (813)	16-3/4 (425)	
6	8	18	5	12 (305)	14 (356)	14-3/4 (375)	5 (127)	3/4 (19)	7/8 (22)	27-1/4 (692)	6 (152)	8 (203)	1-3/4 (44)	4 (102)	18 (457)	16 (406)	8 (203)	2-7/8 (73)	3/8 (10)	3/16 (5)	12 (305)	-	3/4 (19)	32 (813)	18 (457)	
6	8	20	5	12 (305)	14 (356)	14-3/4 (375)	5 (127)	1 (25)	7/8 (22)	27-3/4 (705)	6 (152)	8 (203)	1-3/4 (44)	4 (102)	18 (457)	15-3/4 (400)	8 (203)	2-7/8 (73)	3/8 (10)	3/16 (5)	12 (305)	-	3/4 (19)	32 (813)	18 (457)	
8	10	12	5	12 (305)	14 (356)	14-3/4 (375)	5 (127)	1-1/4 (32)	7/8 (22)	26-3/8 (670)	6 (152)	8 (203)	1-3/4 (44)	4 (102)	18 (457)	17 (432)	9 (229)	2-7/8 (73)	3/8 (10)	3/16 (5)	12 (305)	1-3/4 (44)	2 (51)	32 (813)	17-3/4 (451)	
8	10	15	5	12 (305)	14 (356)	14-3/4 (375)	5 (127)	1-1/4 (32)	7/8 (22)	26-5/8 (676)	6 (152)	8 (203)	1-3/4 (44)	4 (102)	18 (457)	17 (432)	9 (229)	2-7/8 (73)	3/8 (10)	3/16 (5)	12 (305)	1-3/4 (44)	2 (51)	32 (813)	17-3/4 (451)	
8	10	17	5	12 (305)	14 (356)	14-3/4 (375)	5 (127)	1-1/4 (32)	7/8 (22)	27-1/8 (689)	6 (152)	8 (203)	1-3/4 (44)	4 (102)	18 (457)	17 (432)	8 (203)	2-7/8 (73)	3/8 (10)	3/16 (5)	12 (305)	3/4 (19)	2 (51)	32 (813)	17-3/4 (451)	
8	10	21	6B	20 (508)	17 (432)	18-1/2 (470)	9 (229)	1 (25)	7/8 (22)	32-1/2 (826)	7-1/2 (191)	9-1/2 (241)	2-1/8 (54)	5-7/16 (138)	21-7/8 (556)	18 (457)	9-1/2 (241)	4-3/4 (121)	1/2 (13)	1/4 (6)	14-3/8 (365)	-	-	38 (965)	21 (533)	
10	12	12B	6B	15 (381)	22 (559)	23 (584)	6-1/2 (165)	1 (25)	7/8 (22)	35-1/2 (902)	10 (254)	12 (305)	2-1/8 (54)	5-7/16 (138)	21-7/8 (556)	16 (406)	12 (305)	4-3/4 (121)	1/2 (13)	1/4 (6)	11-7/8 (302)	-	-	38 (965)	19 (483)	
10	12	15B&C	6B	15 (381)	22 (559)	25 (635)	6-1/2 (165)	1 (25)	7/8 (22)	38-1/2 (978)	10 (254)	13-1/2 (343)	2-1/8 (54)	5-7/16 (138)	21-7/8 (556)	17 (432)	13-1/2 (343)	4-3/4 (121)	1/2 (13)	1/4 (6)	11-7/8 (302)	-	-	38 (965)	20 (508)	
10	12	18	6B	15 (381)	22 (559)	25 (635)	6-1/2 (165)	1 (25)	7/8 (22)	39-1/2 (1003)	10 (254)	13-1/2 (343)	2-1/8 (54)	5-7/16 (138)	21-7/8 (556)	18 (457)	13-1/2 (343)	4-3/4 (121)	1/2 (13)	1/4 (6)	11-7/8 (302)	-	-	38 (965)	22 (559)	
12	14	15B	7	15 (381)	22 (559)	24 (610)	6-1/2 (165)	1 (25)	7/8 (22)	39 (991)	10 (254)	15 (343)	2-1/2 (64)	6-5/8 (168)	25-1/4 (641)	17 (432)	15 (343)	5 (127)	5/8 (16)	5/16 (8)	15-1/4 (387)	1-1/4 (32)	2-1/2 (64)	43-7/8 (1114)	22 (559)	
12	14	18	7	15 (381)	22 (559)	24 (610)	6-1/2 (165)	1 (25)	7/8 (22)	40-1/8 (1019)	10 (254)	15 (381)	2-1/2 (64)	6-5/8 (168)	25-1/4 (641)	18 (457)	15 (343)	5 (127)	5/8 (16)	5/16 (8)	15-1/4 (387)	1-1/4 (32)	2-1/2 (64)	43-7/8 (1114)	23 (584)	
14	16	18	7	15 (381)	22 (559)	29-1/4 (743)	6-1/2 (165)	1 (25)	7/8 (22)	47-1/2 (1207)	10 (254)	16 (406)	2-1/2 (64)	6-5/8 (168)	25-1/4 (641)	22 (559)	16 (406)	5 (127)	5/8 (16)	5/16 (8)	15-1/4 (387)	-	-	43-7/8 (1114)	27 (686)	

NOTES:

1. All dimensions in inches (mm).
2. Dimensions may vary $\pm 3/8"$ (10).
3. Not for construction purposes unless certified.
4. Discharge and suction flanges - ANSI Standard flat face.

STD. 125# FLANGES	OPT. 250# FLANGES
-------------------	-------------------

AURORA MODEL 411 PUMPS

10" AND 12" BOTTOM SUCTION PUMPS

POWER SERIES NO. 6B & 7

Section **410** Page **203**
 Date **January 2003**
 Supersedes Section 410 Page 203
 Dated October 1984

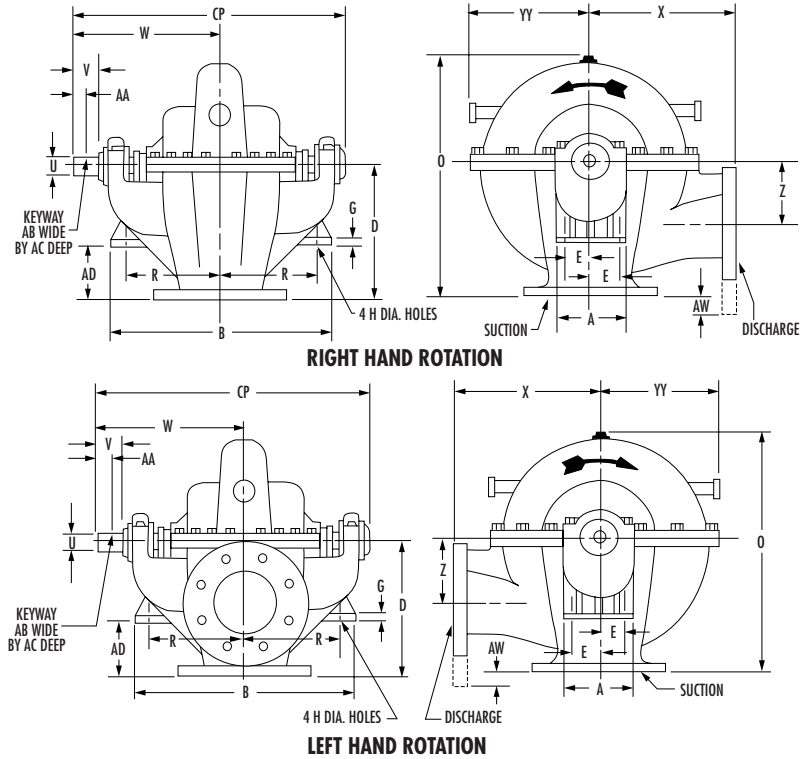

PUMP SIZE			POWER SERIES	A	B	D	E	G	H	O	R	U	V	W	X	Z	AA	AB	AC	AD	AW	CP	YY
DISCH	SUCT	CASE BORE																					
10	12	18	6B	16-3/4 (425)	26 (660)	25 (635)	7-1/2 (191)	1-1/4 (32)	7/8 (22)	39-1/2 (1003)	11-3/4 (298)	2-1/8 (54)	5-7/16 (138)	21-7/8 (556)	18 (457)	13-1/2 (343)	4-3/4 (121)	1/2 (13)	1/4 (6)	12-1/2 (318)	-	38 (965)	18 (457)
12	14	15B	7	21 (533)	32 (813)	25 (635)	9 (229)	1-1/4 (32)	7/8 (22)	40 (1016)	14-1/2 (368)	2-1/2 (64)	6-5/8 (168)	25-1/4 (641)	17 (432)	15 (381)	5 (127)	5/8 (16)	5/16 (8)	13-11/16 (348)	1/4 (6)	43-7/8 (1114)	19 (483)

- NOTES:
- All dimensions in inches (mm).
 - Dimensions may vary $\pm 3/8"$ (10).
 - Not for construction purposes unless certified.
 - Discharge and suction flanges - ANSI Standard flat face.

STD. 125# FLANGES	OPT. 250# FLANGES

AURORA MODEL 412 PUMPS

2" THRU 10" PUMPS

POWER SERIES NO. 1-2-3-4-5-6B

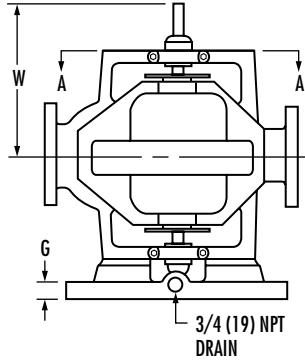
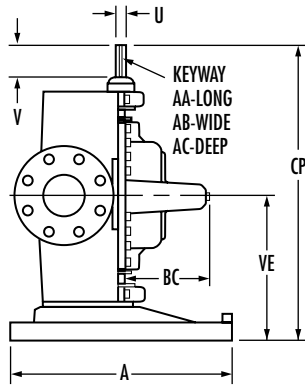

STD. 125# FLANGES	OPT. 250# FLANGES
-------------------	-------------------

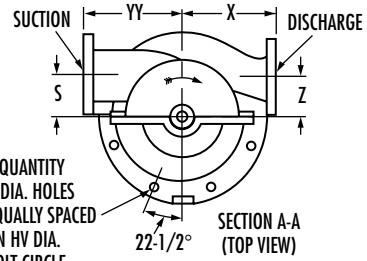

RIGHT HAND ROTATION

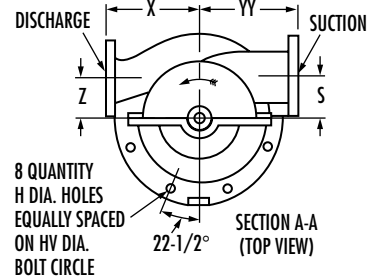

LEFT HAND ROTATION

PUMP SIZE			POWER SERIES	BASE	S	U	V	W	X	Z	AA	AB	AC	BC	CP	VE	YY
DISCH	SUCT	CASE BORE															
2	2-1/2	9	1	1	3-1/2 (89)	3/4 (19)	3-1/2 (89)	11-5/8 (295)	8-1/2 (216)	3-1/2 (89)	2 (51)	3/16 (5)	3/32 (2)	6-3/8 (162)	22-3/4 (578)	11-1/8 (283)	9 (227)
2	2-1/2	10	1	1	3-1/2 (89)	3/4 (19)	3-1/2 (89)	11-5/8 (295)	8-1/2 (216)	3-1/2 (89)	2 (51)	3/16 (5)	3/32 (2)	6-3/8 (162)	22-3/4 (578)	11-1/8 (283)	9 (227)
2	2-1/2	12	1	1	4 (102)	3/4 (19)	3-1/2 (89)	11-5/8 (295)	10 (254)	4 (102)	2 (51)	3/16 (5)	3/32 (2)	7-7/8 (200)	22-3/4 (578)	11-1/8 (283)	10-3/4 (273)
2-1/2	3	10	2	1	4 (102)	1-1/8 (29)	2-7/8 (73)	13-1/2 (343)	9-3/4 (248)	4 (102)	2-1/8 (54)	1/4 (6)	1/8 (3)	8 (203)	26-1/2 (673)	13 (330)	10 (254)
2-1/2	3	12	2	1	4-1/2 (114)	1-1/8 (29)	2-7/8 (73)	13-1/2 (343)	11 (248)	4-1/2 (114)	2-1/8 (54)	1/4 (6)	1/8 (3)	8-1/4 (209)	26-1/2 (673)	13 (330)	11-1/2 (292)
3	4	10	2	1	4-1/2 (114)	1-1/8 (29)	2-7/8 (73)	13-1/2 (343)	10 (254)	4-1/2 (114)	2-1/8 (54)	1/4 (6)	1/8 (3)	7-3/16 (183)	26-1/2 (673)	13 (330)	11 (279)
3	4	14	2	1	5 (127)	1-1/8 (29)	2-7/8 (73)	13-1/2 (343)	12 (305)	5 (127)	2-1/8 (54)	1/4 (6)	1/8 (3)	9-3/8 (238)	26-1/2 (673)	13 (330)	13 (330)
4	5	10	2	1	4-5/8 (117)	1-1/8 (29)	2-7/8 (73)	13-1/2 (343)	10 (254)	4-1/2 (114)	2-1/8 (54)	1/4 (6)	1/8 (3)	7-3/16 (183)	26-1/2 (673)	13 (330)	11-1/4 (286)
4	5	11	3	2	5 (127)	1-3/8 (35)	3 (76)	14-1/2 (356)	11-1/4 (286)	5 (127)	2-3/8 (60)	3/8 (10)	3/16 (5)	8-5/16 (211)	28-1/2 (724)	14 (356)	12-3/4 (324)
4	5	15	3	2	5-1/2 (140)	1-3/8 (35)	3 (76)	14-1/2 (356)	13 (330)	5-1/2 (140)	2-3/8 (60)	3/8 (10)	3/16 (5)	9 (227)	28-1/2 (724)	14 (356)	14 (356)
4	6	18	4	2	6-1/4 (159)	1-1/2 (38)	3-1/2 (89)	16 (406)	14 (356)	6-1/4 (159)	2-7/8 (73)	3/8 (10)	3/16 (5)	11-3/4 (298)	31 (787)	15 (381)	16 (406)
5	6	11	4	2	5-1/2 (140)	1-1/2 (38)	3-1/2 (89)	16 (406)	11-1/4 (286)	5-1/2 (140)	2-7/8 (73)	3/8 (10)	3/16 (5)	8-3/4 (222)	31 (787)	15 (381)	13-1/4 (337)
5	6	15	4	2	6-1/4 (159)	1-1/2 (38)	3-1/2 (89)	16 (406)	13-1/4 (337)	6-1/4 (159)	2-7/8 (73)	3/8 (10)	3/16 (5)	10-1/16 (256)	31 (787)	15 (381)	15 (381)
5	6	17	4	2	6-1/4 (159)	1-1/2 (38)	3-1/2 (89)	16 (406)	14 (356)	6-1/4 (159)	2-7/8 (73)	3/8 (10)	3/16 (5)	10-1/16 (256)	31 (787)	15 (381)	15 (381)
6	8	11	4	2	6-1/4 (159)	1-1/2 (38)	3-1/2 (89)	16 (406)	11-3/4 (298)	6-1/4 (159)	2-7/8 (73)	3/8 (10)	3/16 (5)	9-1/4 (235)	31 (787)	15 (381)	14-1/2 (356)
8	8	11	4	2	6-1/4 (159)	1-1/2 (38)	3-1/2 (89)	16 (406)	12 (305)	6-1/4 (159)	2-7/8 (73)	3/8 (10)	3/16 (5)	9-3/4 (248)	31 (787)	15 (381)	14-1/2 (356)
6	8	15	5	3	6-3/4 (171)	1-3/4 (44)	4 (102)	18 (457)	14-1/4 (362)	6-3/4 (171)	2-7/8 (73)	3/8 (10)	3/16 (5)	11-5/16 (287)	35 (889)	17 (432)	16-3/4 (425)
6	8	18	5	3	8 (203)	1-3/4 (44)	4 (102)	18 (457)	16 (406)	8 (203)	2-7/8 (73)	3/8 (10)	3/16 (5)	12-1/2 (318)	35 (889)	17 (432)	18 (457)
8	8	20	5	3	8 (203)	1-3/4 (44)	4 (102)	18 (457)	15-3/4 (400)	8 (203)	2-7/8 (73)	3/8 (10)	3/16 (5)	12-15/16 (329)	35 (889)	17 (432)	18 (457)
8	10	12	5	3	8 (203)	1-3/4 (44)	4 (102)	18 (457)	17 (432)	9 (227)	2-7/8 (73)	3/8 (10)	3/16 (5)	11-9/16 (294)	35 (889)	17 (432)	17-3/4 (438)
8	10	15	5	3	8 (203)	1-3/4 (44)	4 (102)	18 (457)	17 (432)	9 (227)	2-7/8 (73)	3/8 (10)	3/16 (5)	11-13/16 (300)	35 (889)	17 (432)	17-3/4 (438)
8	10	17	5	3	8 (203)	1-3/4 (44)	4 (102)	18 (457)	17 (432)	8 (203)	2-7/8 (73)	3/8 (10)	3/16 (5)	12-3/8 (314)	35 (889)	17 (432)	17-3/4 (438)
10	12	12B	6B	4	12 (305)	2-1/8 (54)	5-1/2 (140)	21-7/8 (556)	16 (406)	12 (305)	4-3/4 (121)	1/2 (13)	1/4 (6)	12-1/2 (318)	40-7/8 (1038)	19 (483)	19 (483)

BASE	1	2	3	4
A	18 (457)	22 (559)	30 (762)	40 (1016)
G	1-3/4 (44)	1-3/4 (44)	2 (51)	2-1/4 (57)
H	3/4 (19)	3/4 (19)	7/8 (22)	7/8 (22)
HV	16-1/4 (413)	20 (508)	28 (711)	38 (965)

- NOTES:
- All dimensions in inches (mm).
 - Dimensions may vary ± 3/8" (10).
 - Not for construction purposes unless certified.
 - Discharge and suction flanges - ANSI Standard flat face.

AURORA MODEL 411 PUMPS

ON STEEL BASE

Date **FEBRUARY 1999**

2" THRU 4" PUMPS

Supersedes Section 410 Page 251

Dated JULY 1998

POWER SERIES NO. 1-2-3

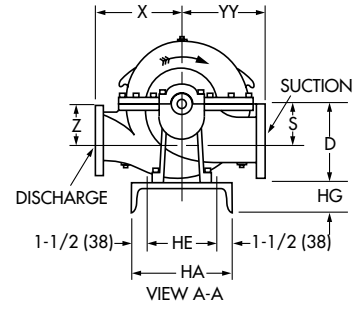
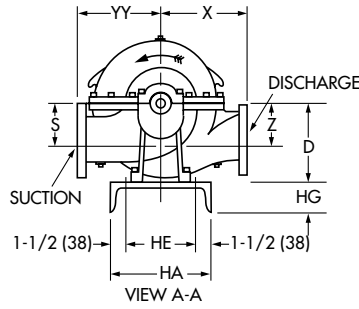
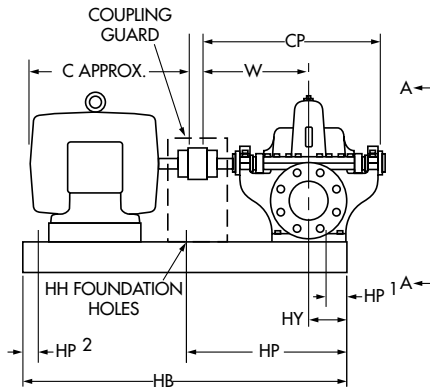

BASE	SIZE	HA	HB	HE	HG	HH			HP	HP1	HP2
						QTY	SIZE	HP			
2	10 x 28	10 (254)	28 (711)	7 (178)	2-5/8 (67)	2	5/8 (16)	14 (356)	-	-	-
3	12 x 30	12 (305)	30 (762)	9 (229)	3 (76)	2	5/8 (16)	15 (381)	-	-	-
4	12 x 34	12 (305)	34 (864)	9 (229)	3 (76)	4	5/8 (16)	20 (508)	-	1 (25)	-
5	12 x 38	12 (305)	38 (965)	9 (229)	3 (76)	4	5/8 (16)	20 (508)	-	1 (25)	-
6	13 x 38	13 (330)	38 (965)	10 (254)	4 (102)	4	3/4 (19)	-	1 (25)	1 (25)	-
7	13 x 42	13 (330)	42 (1067)	10 (254)	4 (102)	4	3/4 (19)	24 (610)	-	1 (25)	-
8	15 x 40	15 (381)	40 (1016)	12 (305)	3-3/8 (86)	4	3/4 (19)	-	1 (25)	1 (25)	-
9	15 x 44	15 (381)	44 (1118)	12 (305)	3-3/8 (86)	4	3/4 (19)	24 (610)	-	1 (25)	-
10	18 x 44	18 (457)	44 (1118)	15 (381)	4 (102)	4	3/4 (19)	-	1 (25)	1 (25)	-
11	18 x 48	18 (457)	48 (1219)	15 (381)	4 (102)	4	3/4 (19)	-	1 (25)	1 (25)	-
12	18 x 54	18 (457)	54 (1372)	15 (381)	4 (102)	4	3/4 (19)	-	1 (25)	1 (25)	-
15	22 x 60	22 (559)	60 (1524)	19 (483)	4 (102)	4	3/4 (19)	-	1 (25)	1 (25)	-

NOTE: WHEN 2 "D" DIMENSIONS ARE INDICATED ALWAYS USE THE LARGER FIGURE.

PUMP SIZE			POWER SERIES	D	S	W	X	Z	CP	HY	YY
DISCH	SUCT	CASE BORE									
2	2-1/2	9	1	7 (178)	3-1/2 (89)	11-5/8 (295)	8-1/2 (216)	3-1/2 (89)	20-1/2 (521)	4 (102)	9 (229)
2	2-1/2	10		7 (178)	3-1/2 (89)		8-1/2 (216)	3-1/2 (89)			9 (229)
2	2-1/2	12	2	8 (203)	4 (102)	13-1/2 (343)	10 (254)	4 (102)	24 (610)	5 (127)	10-3/4 (273)
2-1/2	3	10B		8 (203)	4 (102)		9-3/4 (248)	4 (102)			10 (254)
2-1/2	3	12	2	9** (229)**	4-1/2 (114)	13-1/2 (343)	11 (279)	4-1/2 (114)	24 (610)	5 (127)	11-1/2 (292)
3	4	10B & C		9** (229)**	4-1/2 (114)		10 (254)	4-1/2 (114)			11 (279)
3	4	14	2	10 (254)	5 (127)	13-1/2 (343)	12 (305)	5 (127)	24 (610)	5 (127)	13 (330)
4	5	10B		10 (254)	5 (127)		10 (254)	4-1/2 (114)			11-1/4 (286)
4	5	10B	3	9** (229)**	4-5/8 (118)	14-1/2 (368)	10 (254)	4-1/2 (114)	26 (660)	6 (152)	11-1/4 (286)
4	5	11A & C		10† (254)†	5 (127)		11-1/4 (286)	5 (127)			12-3/4 (324)
4	5	15	3	11 (279)	5-1/2 (140)	14-1/2 (368)	13 (330)	5-1/2 (140)	26 (660)	6 (152)	14 (356)
4	5	15		11 (279)	5-1/2 (140)		13 (330)	5-1/2 (140)			14 (356)

PUMP SIZE	FRAME	143T	145T	182T	184T	213T	215T	254T	256T	284TS	284T	286TS	286T	324TS	324T	326TS	326T	364TS	364T	365TS	365T	404TS	405TS	444TS	
	C	13 (330)	13 (330)	13 (330)	14 (356)	16 (406)	18 (457)	21 (533)	23 (584)	22 (559)	24 (610)	24 (610)	25 (635)	25 (635)	26 (660)	26 (660)	28 (711)	27 (686)	29 (711)	28 (711)	30 (762)	30 (762)	31 (787)	34 (864)	
	D	-	-	-	-	-	-	-	-	-	-	-	-	-	8 (203)	8 (203)	8 (203)	9 (229)	9 (229)	9 (229)	9 (229)	10 (254)	10 (254)	11 (279)	
2 x 2-1/2 x 9	BASE	2		3		4		6		8		9		10											
2 x 2-1/2 x 10	BASE	2		3		4		6		8		9		10											
2 x 2-1/2 x 12	BASE	2		3		4		6		8		9		10											
2-1/2 x 3 x 10B	BASE	2		3		4		6		8		9		10											
2-1/2 x 3 x 12	BASE	2		3		4		6		8		9		10											
3 x 4 x 10B & C	BASE	3		4		5		7		9		10		11		10		11		12					
3 x 4 x 14	BASE	3		4		5		7		9		10		11		10		11		12					
4 x 5 x 10B	BASE	3		4		5		7		9		10		11		10		11		12					
4 x 5 x 11A & C	BASE	3		4		5		7		9		10		11		10		11		12					
4 x 5 x 15	BASE	3		4		5		7		9		10		11		10		11		12					

- NOTES:**
- All dimensions in inches (mm).
 - Dimensions may vary ± 3/8" (10).
 - Not for construction purposes unless certified.
 - Coupling gap may vary 1/8" (3) to 2-1/16" (52).

- Conduit box is shown in approximate location. Dimensions are not specified as they vary with each motor manufacturer.
- Discharge and suction flanges - ANSI Standard flat face.
- ** Dimension "D" is 10-1/2" (267) when using frames 324TS thru 365T.
- † Dimension "D" is 10-1/2" (267) when using frames 404TS thru 405TS.
- ‡ Dimension "D" is 11" (279) when using frames 444TS.

STD. 125# FLANGES	OPT. 250# FLANGES
-------------------	-------------------

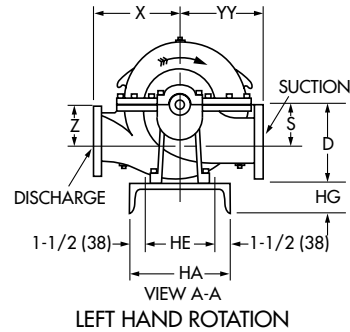
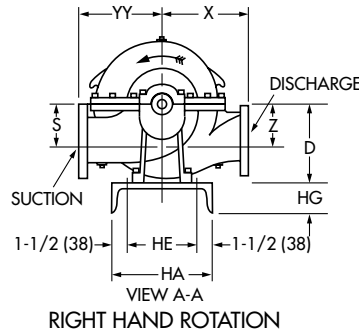
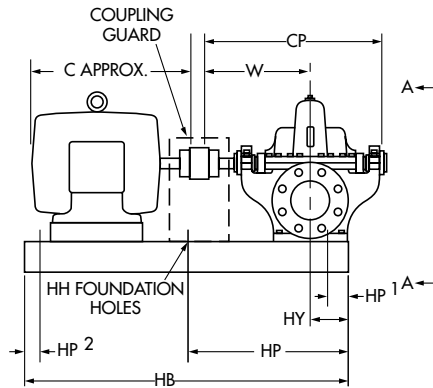

BASE	SIZE	HA	HB	HE	HG	HH				
						QTY	SIZE	HP	HP1	HP2
5	12 x 38	12 (305)	38 (965)	9 (229)	3 (76)	5/8 (16)	20 (508)	-	-	-
7	13 x 42	13 (330)	42 (1067)	10 (254)	4 (102)	24 (610)	-	-	-	-
9	15 x 44	15 (381)	44 (1118)	12 (305)	3-3/8 (86)	24 (610)	-	-	-	-
10	18 x 44	18 (457)	44 (1219)	15 (381)	4 (102)	-	-	-	-	-
11	18 x 48	18 (457)	48 (1219)	15 (381)	4 (102)	-	1 (25)	-	-	-
12	18 x 54	18 (457)	54 (1372)	15 (381)	4 (102)	-	-	-	1 (25)	-
13	18 x 60	18 (457)	60 (1524)	15 (381)	4 (102)	24 (610)	-	-	-	-
14	18 x 65	18 (457)	65 (1651)	15 (381)	4 (102)	24 (610)	-	-	-	-
15	22 x 60	22 (559)	60 (1524)	19 (483)	4 (102)	-	-	-	-	-
16	22 x 72	22 (559)	72 (1829)	19 (483)	4 (102)	-	1 (25)	-	-	-
17	22 x 84	22 (559)	84 (2134)	19 (483)	4 (102)	-	-	-	-	-

PUMP SIZE			POWER SERIES	DIMENSIONS									
DISCH	SUCT	CASE BORE		D	S	W	X	Z	CP	HY	YY		
4	6	18B	4	12-1/2 (318)	6-1/4 (159)	16 (406)	14 (356)	6-1/4 (159)	28-1/2 (724)	6 (152)	16 (406)		
5	6	11A & C		11** (279)**	5-1/2 (140)		11-1/4 (286)	5-1/2 (140)			13-1/4 (337)	6-1/4 (159)	13-1/4 (337)
5	6	15		12-1/2 (318)	6-1/4 (159)		14 (356)	6-1/4 (159)			13-1/4 (337)	6-1/4 (159)	15 (381)
5	6	17		12-1/2 (318)	6-1/4 (159)		14 (356)	6-1/4 (159)			13-1/4 (337)	6-1/4 (159)	15 (381)
6	8	11		12-1/2 (318)	6-1/4 (159)		11-3/4 (286)	6-1/4 (159)			11-3/4 (286)	6-1/4 (159)	14-1/2 (368)
8	8	11B		12-1/2† (318†)	6-1/4 (159)		12 (305)	6-1/4 (159)			12 (305)	6-1/4 (159)	14-1/2 (368)
6	8	15	5	13-1/2 (343)	6-3/4 (171)	18 (457)	14-1/4 (362)	6-3/4 (171)	32 (813)	7 (178)	16-3/4 (425)		
6	8	18A, B & C		14-3/4 (375)	8 (203)		16 (406)	8 (203)			16 (406)	8 (203)	18 (457)
6	8	20		14-3/4 (375)	8 (203)		15-3/4 (400)	8 (203)			15-3/4 (400)	8 (203)	18 (457)
8	10	12 & 12A		14-3/4 (375)	8 (203)		17 (432)	9 (229)			17 (432)	9 (229)	17-3/4 (451)
8	10	15A & B		14-3/4 (375)	8 (203)		17 (432)	9 (229)			17 (432)	9 (229)	17-3/4 (451)
8	10	17B		14-3/4 (375)	8 (203)		17 (432)	8 (203)			17 (432)	8 (203)	17-3/4 (451)

FRAME		213T	215T	254T	256T	284TS	284T	286TS	286T	324TS	324T	326TS	326T	364TS	364T	365TS	365T	404TS	404T	405TS	405T	444TS	444T	445TS	445T	447TS	447T	449TS	449T
4 x 6 x 18B	BASE	16 (406)	18 (457)	21 (533)	23 (584)	22 (559)	24 (610)	24 (610)	25 (635)	25 (635)	26 (660)	26 (660)	28 (711)	27 (686)	29 (737)	28 (711)	30 (762)	30 (762)	33 (838)	31 (787)	35 (889)	34 (864)	38 (965)	36 (1016)	40 (914)	40 (914)	44 (1118)	45 (1143)	49 (1245)
5 x 6 x 11A & C	BASE	5	7	9	10	11	11	11	11	11	11	11	11	11	11	11	11	11	11	11	11	11	11	11	11	11	11	11	11
5 x 6 x 15	BASE																												
5 x 6 x 17	BASE																												
6 x 8 x 11	BASE																												
8 x 8 x 11B	BASE																												
6 x 8 x 15	BASE	-	-	-	-	-	-	-	-	-	-	-	-	-	-	-	-	-	-	-	-	-	-	-	-	-	-	-	-
6 x 8 x 18A, B, & C	BASE	-	-	-	-	-	-	-	-	-	-	-	-	-	-	-	-	-	-	-	-	-	-	-	-	-	-	-	-
6 x 8 x 20	BASE	-	-	-	-	-	-	-	-	-	-	-	-	-	-	-	-	-	-	-	-	-	-	-	-	-	-	-	-
8 x 10 x 12 & 12A	BASE	-	-	-	-	-	-	-	-	-	-	-	-	-	-	-	-	-	-	-	-	-	-	-	-	-	-	-	-
8 x 10 x 15A & B	BASE	-	-	-	-	-	-	-	-	-	-	-	-	-	-	-	-	-	-	-	-	-	-	-	-	-	-	-	-
8 x 10 x 17B	BASE	-	-	-	-	-	-	-	-	-	-	-	-	-	-	-	-	-	-	-	-	-	-	-	-	-	-	-	-

- NOTES:
- All dimensions in inches (mm).
 - Dimensions may vary ± 3/8" (10).
 - Not for construction purposes unless certified.
 - Coupling gap may vary 1/8" (3) to 2-1/16" (52).
 - Conduit box is shown in approximate location.
 - Discharge and suction flanges - ANSI Standard flat face.
- ** Dimension "D" is 12" (305) when using frames 404TS thru 449T.
† Dimension "D" is 14-1/2" (368) when using frames 404TS thru 449T.
- Dimensions are not specified as they vary with each motor manufacturer.

STD. 125# FLANGES	OPT. 250# FLANGES
-------------------	-------------------

AURORA MODEL 411 PUMPS

ON STEEL BASE

Date **FEBRUARY 1999**

8" THRU 12" PUMPS

Supersedes Section 410 Page 253

Dated JULY 1998

POWER SERIES NO. 6B & 7

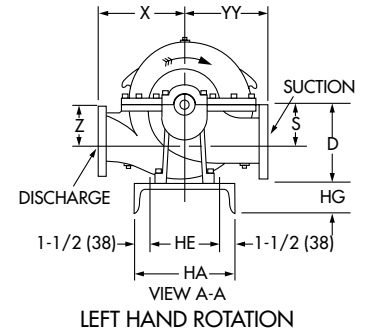
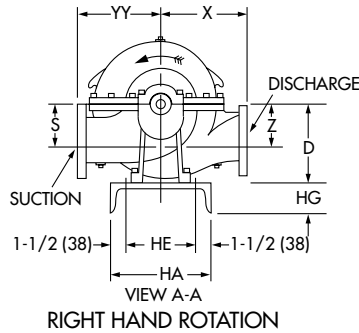
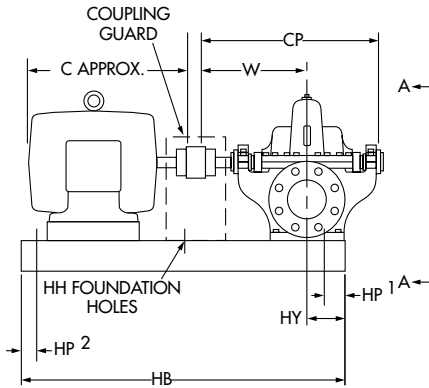

BASE	SIZE	HA	HB	HE	HG	HH		HP1	HP2
						QTY	SIZE		
13	18 x 60	18 (457)	60 (1524)	15 (381)	4 (102)	4	3/4 (19)	24 (610)	1 (25)
14	18 x 65	18 (457)	65 (1651)	15 (381)	4 (102)	4	3/4 (19)	24 (610)	1 (25)
15	22 x 60	22 (559)	60 (1524)	19 (483)	4 (102)	4	3/4 (19)	1 (25)	1 (25)
16	22 x 72	22 (559)	72 (1829)	19 (483)	4 (102)	4	3/4 (19)	1 (25)	1 (25)
17	22 x 84	22 (559)	84 (2134)	19 (483)	4 (102)	4	3/4 (19)	1 (25)	1 (25)

PUMP SIZE		CASE BORE	POWER SERIES	D	S	W	X	Z	CP	HY	YY	
DISCH	SUCT											
8	10	21 & 21A	6B	18-1/2 (470)	9-1/2 (241)	21-7/8 (556)	18 (457)	9-1/2 (241)	38 (965)	11 (279)	21 (533)	
		12B		23 (584)	12 (305)	21-7/8 (556)	16 (406)	12 (305)	38 (965)	11 (279)	19 (483)	
		15B & C		25 (635)	13-1/2 (343)	27-7/8 (708)	17 (432)	13-1/2 (343)	38 (965)	11 (279)	20 (508)	
	10	12		18	25 (635)	13-1/2 (343)	27-7/8 (708)	18 (457)	13-1/2 (343)	38 (965)	11 (279)	22 (559)
				15B	24 (610)	15 (381)	25-1/4 (641)	17 (432)	15 (381)	43-7/8 (1114)	11 (279)	22 (559)
				18A	24 (610)	15 (381)	25-1/4 (641)	18 (457)	15 (381)	43-7/8 (1114)	11 (279)	23 (584)
14	16	18	29-1/4 (743)	16 (406)	25-1/4 (641)	22 (559)	16 (406)	43-7/8 (1114)	11 (279)	27 (686)		

PUMP SIZE	FRAME	286TS	286T	324TS	324T	326TS	326T	364TS	364T	365TS	365T	404TS	404T	405TS	405T	444TS	444T	445TS	445T	447TS	447T	449TS	449T
	C	24 (610)	25 (635)	25 (635)	26 (660)	26 (660)	28 (711)	27 (686)	29 (737)	28 (711)	30 (762)	30 (762)	33 (838)	31 (787)	35 (889)	34 (864)	38 (965)	36 (1016)	40 (914)	40 (914)	44 (1118)	45 (1143)	49
8 x 10 x 21 & 21A	BASE	13				14				16				17									
10 x 12 x 12B	BASE	13				14				16				17									
10 x 12 x 15B & C	BASE	13				14				16				17									
10 x 12 x 18	BASE	13				14				16				17									
12 x 14 x 15B	BASE	13				14				16				17									
12 x 14 x 18A	BASE	13				14				16				17									
14 x 16 x 18	BASE	13				14				16				17									

NOTES:

- All dimensions in inches (mm).
- Dimensions may vary $\pm 3/8"$ (10).
- Not for construction purposes unless certified.
- Coupling gap may vary 1/8" (3) to 2-1/16" (52).
- Conduit box is shown in approximate location.
Dimensions are not specified as they vary with each motor manufacturer.
- Discharge and suction flanges - ANSI Standard flat face.

<input type="checkbox"/>	<input type="checkbox"/>
STD. 125# FLANGES	OPT. 250# FLANGES

AURORA MODEL 411 PUMPS

ON STEEL DRIP RIM BASE

2"-2-1/2"-3"-4" PUMPS

POWER SERIES NO. 1-2-3

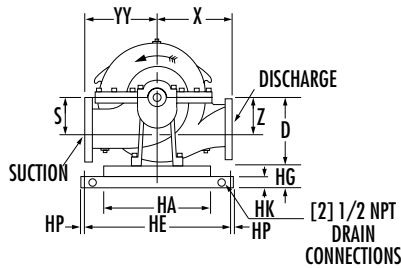
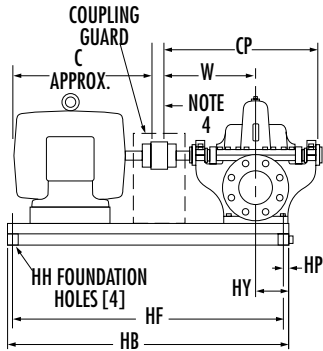

RIGHT HAND ROTATION

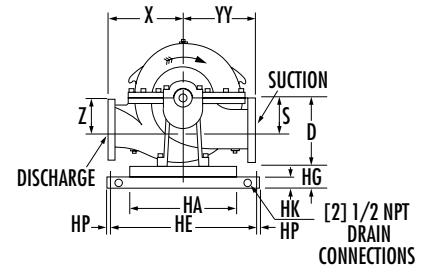

LEFT HAND ROTATION

BASE	SIZE	HA	HB	HE	HF	HG	HH	HK	HP
3	9 x 33	9 (229)	33-1/2 (851)	13-3/4 (349)	32-1/4 (819)	3 (76)	3/4 (19)	1-1/2 (38)	5/8 (16)
5	11 x 36	11 (279)	36-1/2 (927)	15-7/8 (403)	35-1/8 (892)	3 (76)	7/8 (22)	1-1/2 (38)	11/16 (18)
6	11 x 42	11 (279)	42-1/2 (1080)	15-7/8 (403)	41-1/8 (1045)	3 (76)	7/8 (22)	1-1/2 (38)	11/16 (18)
8	14 x 42	14 (356)	42-1/2 (1080)	19 (483)	41 (1041)	3 (76)	1 (25)	1-1/2 (38)	3/4 (19)
9	14 x 48	14 (356)	48-1/2 (1232)	19 (483)	47 (1194)	3 (76)	1 (25)	1-1/2 (38)	3/4 (19)
11	18 x 46	18 (457)	46-1/2 (1181)	25-1/8 (638)	44-7/8 (1140)	4 (102)	1-1/8 (29)	2 (51)	13/16 (21)
12	18 x 54	18 (457)	54-1/2 (1384)	25-1/8 (638)	52-7/8 (1343)	4 (102)	1-1/8 (29)	2 (51)	13/16 (21)
15	22 x 54	22 (559)	54-1/2 (1384)	29-1/8 (740)	52-7/8 (1343)	4-1/2 (114)	1-1/8 (29)	2 (51)	13/16 (21)

NOTE: WHEN 2 "D" DIMENSIONS ARE INDICATED ALWAYS USE THE LARGER FIGURE.

PUMP SIZE		CASE BORE	POWER SERIES	D	S	W	X	Z	CP	HY	YY
DISCH	SUCT										
2	2-1/2	9	1	7 (178)	3-1/2 (89)	11-5/8 (295)	8-1/2 (216)	3-1/2 (89)	20-1/2 (521)	4-1/2 (114)	9 (229)
2	2-1/2	10		7 (178)	3-1/2 (89)		8-1/2 (216)	3-1/2 (89)		9 (229)	
2	2-1/2	12		8 (203)	4 (102)		10 (254)	4 (102)		10-3/4 (273)	
2-1/2	3	10B	2	8 (203)	4 (102)	13-1/2 (343)	9-3/4 (248)	4 (102)	24 (610)	5-1/2 (140)	10 (254)
2-1/2	3	12		9** (229)**	4-1/2 (114)		10 (279)	4-1/2 (114)		11 (292)	
3	4	10B & C		9** (229)**	4-1/2 (114)		10 (254)	4-1/2 (114)		11 (279)	
3	4	14	2	10 (254)	5 (127)	13-1/2 (343)	12 (305)	5 (127)	24 (610)	5-1/2 (140)	13 (330)
4	5	10B		9** (229)**	4-5/8 (118)		10 (254)	4-1/2 (114)		11-1/4 (286)	
4	5	11A & C		10† (254†)	5 (127)		11-1/4 (286)	5 (127)		12-3/4 (324)	
4	5	15	3	11 (279)	5-1/2 (140)	14-1/2 (368)	13 (330)	5-1/2 (140)	26 (660)	6-1/2 (165)	14 (356)
4	5	15		11 (279)	5-1/2 (140)		13 (330)	5-1/2 (140)		14 (356)	

PUMP SIZE			POWER SERIES	FRAME	143T	145T	182T	184T	213T	215T	254T	256T	284TS	284T	286TS	286T	324TS	324T	326TS	326T	364TS	364T	365TS	365T	404TS	405TS	444TS								
DISCH	SUCT	CASE BORE		C	13 (330)	13 (330)	13 (330)	14 (356)	16 (406)	18 (457)	21 (533)	23 (584)	22 (559)	24 (610)	24 (610)	24 (635)	25 (635)	26 (660)	26 (660)	28 (711)	27 (686)	29 (737)	28 (711)	30 (762)	30 (762)	31 (787)	31 (787)	34 (864)							
			D	-	-	-	-	-	-	-	-	-	-	-	-	8 (203)	8 (203)	8 (203)	8 (203)	9 (229)	9 (229)	9 (229)	9 (229)	10 (254)	10 (254)	11 (279)									
2	2-1/2	9	1	BASE	3			5			8			11																					
2	2-1/2	10		BASE																															
2	2-1/2	12		BASE																															
2-1/2	3	10B	2	BASE	3			5			8			9			11			12															
2-1/2	3	12		BASE																															
3	4	10B & C		BASE																															
3	4	14	BASE																																
4	5	10B	BASE																																
4	5	11A & C	3	BASE	5			6			8			9			11			12			15												
4	5	15		BASE																															

NOTES:

- All dimensions in inches (mm).
- Dimensions may vary ± 3/8" (10).
- Not for construction purposes unless certified.
- Coupling gap may vary 1/8" (3) to 2-1/16" (52).
- Conduit box is shown in approximate location. Dimensions are not specified as they vary with each motor manufacturer.

- Discharge and suction flanges - ANSI Standard flat face.
- ** Dimension "D" is 10-1/2" (267) when using frames 324TS thru 365T.
- † Dimension "D" is 10-1/2" (267) when using frames 404TS thru 405T.

STD. 125# FLANGES	OPT. 250# FLANGES

AURORA MODEL 411 PUMPS

ON STEEL DRIP RIM BASE

4" - 5" - 6" - 8" PUMPS

POWER SERIES NO. 4-5

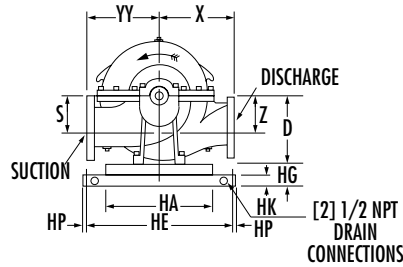
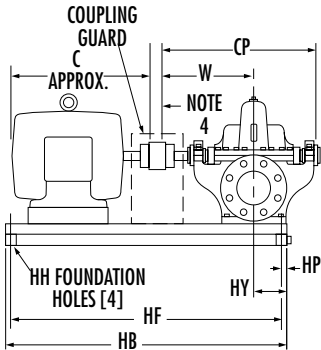

RIGHT HAND ROTATION

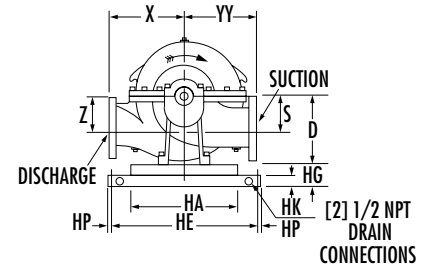

LEFT HAND ROTATION

BASE	SIZE	HA	HB	HE	HF	HG	HH	HK	HP
6	11 x 42	11 (279)	42-1/2 (1080)	15-7/8 (403)	41-1/8 (1045)	3 (76)	7/8 (22)	1-1/2 (38)	11-1/16 (18)
9	14 x 48	14 (356)	48-1/2 (1232)	19 (483)	47 (1194)	3 (76)	1 (25)	1-1/2 (38)	3/4 (19)
11	18 x 46	18 (457)	46-1/2 (1181)	25-1/8 (638)	44-7/8 (1140)	4 (102)	1-1/8 (29)	2 (51)	13/16 (21)
12	18 x 54	18 (457)	54-1/2 (1384)	25-1/8 (638)	52-7/8 (1343)	4 (102)	1-1/8 (29)	2 (51)	13/16 (21)
13	18 x 64	18 (457)	64-1/2 (1638)	25-1/8 (638)	62-7/8 (1597)	4 (102)	1-1/8 (29)	2 (51)	13/16 (21)
15	22 x 54	22 (559)	54-1/2 (1384)	29-1/8 (740)	52-7/8 (1343)	4-1/2 (114)	1-1/8 (29)	2 (51)	13/16 (21)
16	22 x 64	22 (559)	64-1/2 (1638)	29-1/8 (740)	62-7/8 (1597)	4-1/2 (114)	1-1/8 (29)	2 (51)	13/16 (21)
17	22 x 74	22 (559)	74-1/2 (1892)	29-1/8 (740)	72-7/8 (1851)	4-1/2 (114)	1-1/8 (29)	2 (51)	13/16 (21)
18	22 x 82	22 (559)	82-1/2 (2096)	29-1/8 (740)	80-7/8 (2054)	4-1/2 (114)	1-1/8 (29)	2 (51)	13/16 (21)

PUMP SIZE			PUMP SERIES	D	S	W	X	Z	CP	HY	YY		
DISCH	SUCT	CASE BORE											
4	6	18B	4	12-1/2 (318)	6-1/4 (159)	16 (408)	14 (356)	6-1/4 (159)	28-1/2 (734)	6-1/2 (165)	16 (406)		
5	6	11A & C		11** (279)**	5-1/2 (140)		11-1/4 (286)	5-1/2 (140)			13-1/4 (337)	6-1/4 (159)	15 (381)
5	6	15		12-1/2 (318)	6-1/4 (159)		13-1/4 (337)	6-1/4 (159)			15 (381)		
5	6	17		12-1/2 (318)	6-1/4 (159)		14 (356)	6-1/4 (159)			15 (381)		
6	8	11		12-1/2 (318)	6-1/4 (159)		11-3/4 (298)	6-1/4 (159)			14-1/2 (368)		
8	8	11B		12-1/2† (318†)	6-1/4 (159)		12 (305)	6-1/4 (159)			14-1/2 (368)		
6	8	15		13-1/2 (343)	6-3/4 (171)		14-1/4 (362)	6-3/4 (171)			16-3/4 (425)		
6	8	18A, B & C		14-3/4 (375)	8 (203)		16 (406)	8 (203)			18 (457)		
6	8	20	14-3/4 (375)	8 (203)	15-3/4 (400)	8 (203)	18 (457)						
8	10	12 & 12A	5	14-3/4 (375)	8 (203)	18 (457)	17 (432)	9 (229)	32 (813)	7-1/2 (191)	17-3/4 (451)		
8	10	15A & B		14-3/4 (375)	8 (203)		17 (432)	9 (229)			17-3/4 (451)		
8	10	17B		14-3/4 (375)	8 (203)		17 (432)	8 (203)			17-3/4 (451)		

PUMP SIZE		FRAME	213T	215T	254T	256T	284TS	284T	286TS	286T	324TS	324T	326TS	326T	364TS	364T	365TS	365T	36TS	30	30	33	31	35	34	38	36	40	40	44	447T	449TS	449T
DISCH	SUCT	CASE BORE	C	16	18	21	23	22	24	24	25	25	26	26	28	27	29	28	30	30	33	31	35	34	38	36	40	40	44	45	49		
4	6	18B	BASE	16	18	21	23	22	24	24	25	25	26	26	28	27	29	28	30	30	33	31	35	34	38	36	40	40	44	45	49		
5	6	11A & C	BASE	6	9	11	12	15	16	17	18	19	20	21	22	23	24	25	26	27	28	29	30	31	32	33	34	35	36	37	38	39	
5	6	15	BASE	6	9	11	12	15	16	17	18	19	20	21	22	23	24	25	26	27	28	29	30	31	32	33	34	35	36	37	38	39	
5	6	17	BASE	6	9	11	12	15	16	17	18	19	20	21	22	23	24	25	26	27	28	29	30	31	32	33	34	35	36	37	38	39	
6	8	11	BASE	6	9	11	12	15	16	17	18	19	20	21	22	23	24	25	26	27	28	29	30	31	32	33	34	35	36	37	38	39	
6	8	11B	BASE	6	9	11	12	15	16	17	18	19	20	21	22	23	24	25	26	27	28	29	30	31	32	33	34	35	36	37	38	39	
6	8	15	BASE	6	9	11	12	15	16	17	18	19	20	21	22	23	24	25	26	27	28	29	30	31	32	33	34	35	36	37	38	39	
6	8	18A, B & C	BASE	6	9	11	12	15	16	17	18	19	20	21	22	23	24	25	26	27	28	29	30	31	32	33	34	35	36	37	38	39	
6	8	20	BASE	6	9	11	12	15	16	17	18	19	20	21	22	23	24	25	26	27	28	29	30	31	32	33	34	35	36	37	38	39	
8	10	12 & 12A	BASE	6	9	11	12	15	16	17	18	19	20	21	22	23	24	25	26	27	28	29	30	31	32	33	34	35	36	37	38	39	
8	10	15A & B	BASE	6	9	11	12	15	16	17	18	19	20	21	22	23	24	25	26	27	28	29	30	31	32	33	34	35	36	37	38	39	
8	10	17B	BASE	6	9	11	12	15	16	17	18	19	20	21	22	23	24	25	26	27	28	29	30	31	32	33	34	35	36	37	38	39	

NOTES:

- All dimensions in inches (mm).
- Dimensions may vary ± 3/8" (10).
- Not for construction purposes unless certified.
- Coupling gap may vary 1/8" (3) to 2-1/16" (52).
- Conduit box is shown in approximate location. Dimensions are not specified as they vary with each motor manufacturer.
- Discharge and suction flanges - ANSI Standard flat face.

** Dimension "D" is 12" (305) when using frames 405TS-449T.

† Dimension "D" is 14-1/2" (368) when using frames 404TS thru 449T.

STD. 125# FLANGES	OPT. 250# FLANGES
-------------------	-------------------

AURORA MODEL 411 PUMPS

ON STEEL DRIP RIM BASE

8"-10"-12"-14" PUMPS

POWER SERIES NO. 6B-7

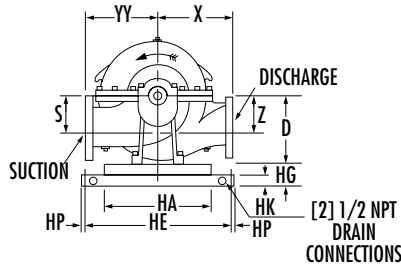
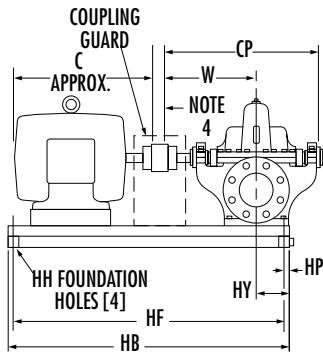

RIGHT HAND ROTATION

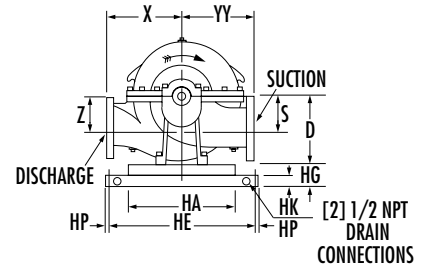

LEFT HAND ROTATION

BASE	SIZE	HA	HB	HE	HF	HG	HH	HK	HP
13	18 x 64	18 (457)	64-1/2 (1638)	25-1/8 (638)	62-7/8 (1597)	4 (102)	1-1/8 (29)	2 (51)	13/16 (21)
17	22 x 74	22 (559)	74-1/2 (1892)	29-1/8 (740)	72-7/8 (1851)	4-1/2 (114)	1-1/8 (29)	2 (51)	13/16 (21)
18	22 x 82	22 (559)	82-1/2 (2096)	29-1/8 (740)	80-7/8 (2054)	4-1/2 (114)	1-1/8 (29)	2 (51)	13/16 (21)

PUMP SIZE			PUMP SERIES	D	S	W	X	Z	CP	HY	YY
DISCH	SUCT	CASE BORE									
8	10	21 & 21A	6B	18-1/2 (467)	9-1/2 (241)	21-7/8 (556)	18 (457)	9-1/2 (241)	38 (965)	11-1/2 (292)	21 (533)
10	12	12B		23 (584)	12 (305)		16 (406)	12 (305)			19 (483)
10	12	15B & C		25 (635)	13-1/2 (343)		17 (432)	13-1/2 (343)			20 (508)
10	12	18		25 (635)	13-1/2 (343)		18 (457)	13-1/2 (343)			22 (559)
12	14	15B		24 (610)	15 (381)		17 (432)	15 (381)			22 (559)
12	14	18A		24 (610)	15 (381)		18 (457)	15 (381)			23 (584)
14	16	18	7	29-1/4 (743)	16 (406)	25-1/4 (641)	22 (559)	16 (406)	43-7/8 (1114)	11-1/2 (292)	27 (686)

PUMP SIZE			FRAME	286TS	286T	324TS	324T	326TS	326T	364TS	364T	365TS	365T	404TS	404T	405TS	405T	444TS	444T	445TS	445T	447TS	447T	449TS	449T
DISCH	SUCT	CASE BORE	C	24 (610)	25 (635)	25 (635)	26 (660)	26 (660)	28 (711)	27 (686)	29 (737)	28 (711)	30 (762)	30 (762)	33 (838)	31 (787)	35 (889)	34 (864)	38 (965)	36 (914)	40 (1016)	40 (1016)	44 (1118)	45 (1143)	49 (1245)
8	10	21 & 21A	BASE														13		17		18				
10	12	12B	BASE														13		17		18				
10	12	15B & C	BASE														13		17		18				
10	12	18	BASE														13		17		18				
12	14	15B	BASE														13		17		18				
12	14	18A	BASE														13		17		18				
14	16	18	BASE														13		17		18				

NOTES:

- All dimensions in inches (mm).
- Dimensions may vary $\pm 3/8"$ (10).
- Not for construction purposes unless certified.
- Coupling gap may vary 1/8" (3) to 2-1/16" (52).
- Conduit box is shown in approximate location. Dimensions are not specified as they vary with each motor manufacturer.
- Discharge and suction flanges - ANSI Standard flat face.

STD. 125# FLANGES	OPT. 250# FLANGES
-------------------	-------------------